

PARTS MANUAL



Mikasa **SERIES**
MODEL MTX50HD
TAMPING RAMMER
(HONDA GX100RTKRBFGASOLINE ENGINE)

Revision #8 (01/06/25)

To find the latest revision of this publication or associated operation manual, visit our website at: www.multiquip.com



THIS MANUAL MUST ACCOMPANY THE EQUIPMENT AT ALL TIMES.

TABLE OF CONTENTS

MTX50HD

Rammer

Explanation Of Code In Remarks Column.....	4
Suggested Spare Parts	5

Rammer Component Drawings

Nameplates And Decals	6-7
Crankcase And Engine Assembly.....	8-11
Guide Cylinder Assembly	12-13
Foot Assembly	14-15
Fuel Tank And Handle Assembly	16-17
Combination Lever Assembly	18-19
Tools Assembly.....	20-21

Honda GX100RTKRBF Engine

Cylinder Barrel Assembly	22-23
Crankcase Cover Assembly	24-25
Crankshaft Assembly.....	26-27
Piston/Connecting Rod Assembly	28-29
Camshaft Pulley Assembly	30-31
Recoil Starter Assembly	32-33
Fan Cover Assembly	34-35
Carburetor Assembly	36-37
Elbow Air Cleaner Assembly	38-39
Muffler Assembly	40-41
Flywheel/Ign. Coil Assembly	42-43
Control Assembly.....	44-45
Label Assembly	46-47

NOTICE

Specifications and part numbers are subject to change without notice.

EXPLANATION OF CODE IN REMARKS COLUMN

The following section explains the different symbols and remarks used in the Parts section of this manual. Use the help numbers found on the back page of the manual if there are any questions.

NOTICE

The contents and part numbers listed in the parts section are subject to change without notice. Multiquip does not guarantee the availability of the parts listed.

SAMPLE PARTS LIST

NO.	PART NO.	PART NAME	QTY.	REMARKS
1	12345	BOLT	1	INCLUDES ITEMS W/%
2%		WASHER, 1/4 IN.		NOT SOLD SEPARATELY
2%	12347	WASHER, 3/8 IN. ...	1	MQ-45T ONLY
3	12348	HOSE	A/R	MAKE LOCALLY
4	12349	BEARING	1	S/N 2345B AND ABOVE

NO. Column

Unique Symbols — All items with same unique symbol (@, #, +, %, or >) in the number column belong to the same assembly or kit, which is indicated by a note in the “Remarks” column.

Duplicate Item Numbers — Duplicate numbers indicate multiple part numbers, which are in effect for the same general item, such as different size saw blade guards in use or a part that has been updated on newer versions of the same machine.

NOTICE

When ordering a part that has more than one item number listed, check the remarks column for help in determining the proper part to order.

PART NO. Column

Numbers Used — Part numbers can be indicated by a number, a blank entry, or TBD.

TBD (To Be Determined) is generally used to show a part that has not been assigned a formal part number at the time of publication.

A blank entry generally indicates that the item is not sold separately or is not sold by Multiquip. Other entries will be clarified in the “Remarks” Column.

QTY. Column

Numbers Used — Item quantity can be indicated by a number, a blank entry, or A/R.

A/R (As Required) is generally used for hoses or other parts that are sold in bulk and cut to length.

A blank entry generally indicates that the item is not sold separately. Other entries will be clarified in the “Remarks” Column.

REMARKS Column

Some of the most common notes found in the “Remarks” Column are listed below. Other additional notes needed to describe the item can also be shown.

Assembly/Kit — All items on the parts list with the same unique symbol will be included when this item is purchased.

Indicated by:

“INCLUDES ITEMS W/(unique symbol)”

Serial Number Break — Used to list an effective serial number range where a particular part is used.

Indicated by:

“S/N XXXXX AND BELOW”

“S/N XXXX AND ABOVE”

“S/N XXXX TO S/N XXX”

Specific Model Number Use — Indicates that the part is used only with the specific model number or model number variant listed. It can also be used to show a part is NOT used on a specific model or model number variant.

Indicated by:

“XXXXX ONLY”

“NOT USED ON XXXX”

“Make/Obtain Locally” — Indicates that the part can be purchased at any hardware shop or made out of available items. Examples include battery cables, shims, and certain washers and nuts.

“Not Sold Separately” — Indicates that an item cannot be purchased as a separate item and is either part of an assembly/kit that can be purchased, or is not available for sale through Multiquip.

SUGGESTED SPARE PARTS

MTX50HD TAMPING RAMMER WITH HONDA GX100RTKRBF ENGINE

1 to 3 units

Qty.	P/N	Description
1.....	956100062.....	THROTTLE WIRE
3.....	366010070.....	PRIMARY ELEMENT, AIR CLEANER
3.....	366010080.....	SECONDARY ELEMENT, AIR CLEANER
1.....	366350460.....	CAP ASSY., FUEL TANK
2.....	16910Z4ES21.....	FILTER, IN-LINE FUEL
3.....	9805655777.....	SPARK PLUG
1.....	954406010.....	STRAINER, FUEL TANK
1.....	28462Z0DV03.....	ROPE, RECOIL STARTER
1.....	366900032.....	COMBO. LEVER W/THROTTLE WIRE
1.....	956200110.....	COMBO. LEVER W/O THROTTLE WIRE
1.....	366900170.....	CUP AND PACKING SET
1.....	366348550.....	CLUTCH ASSY

NOTICE

Part numbers on this Suggested Spare Parts list may supersede/replace the part numbers shown in the following parts lists.

NAMEPLATES AND DECALS

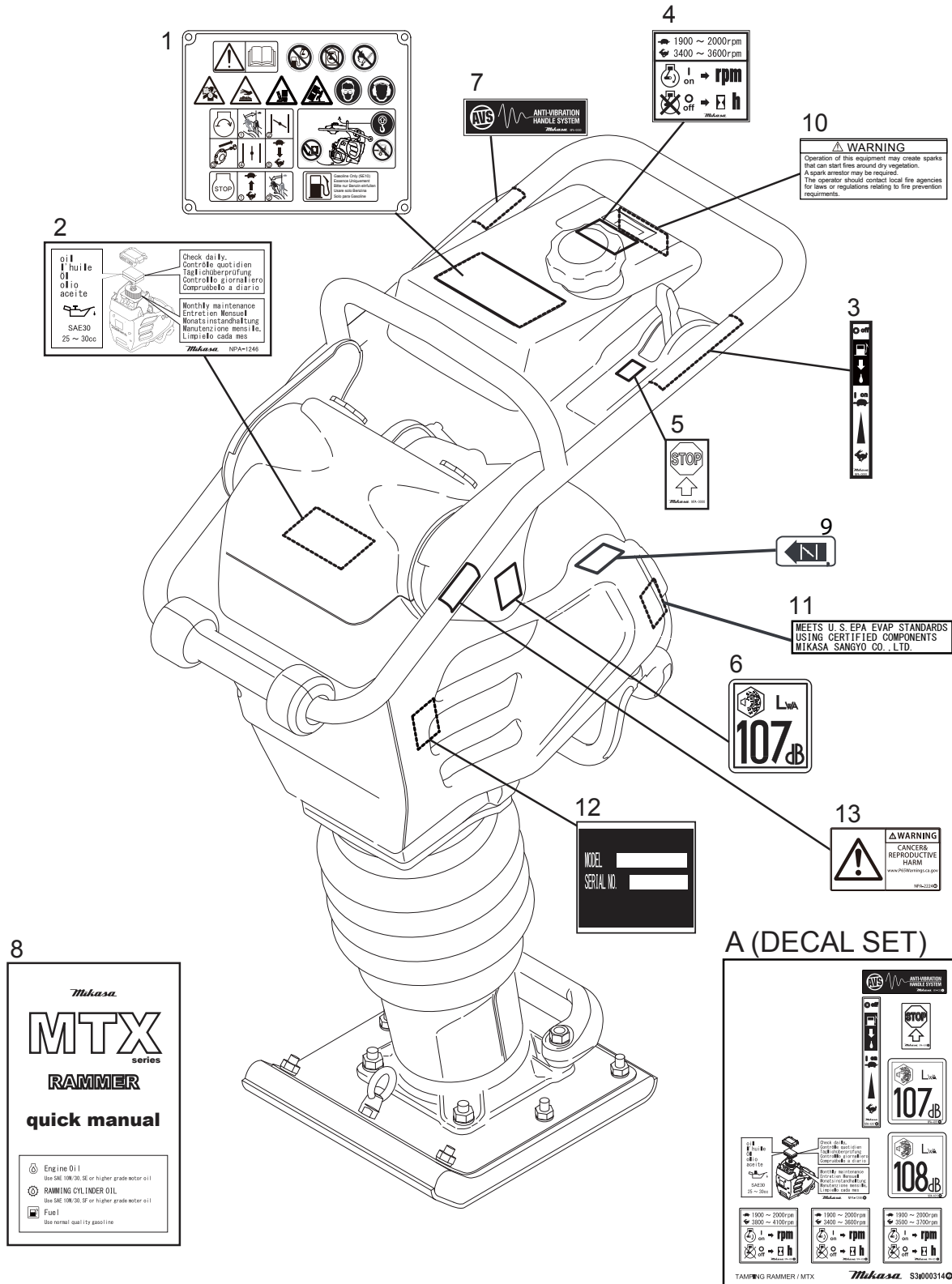

8

Mikasa

MTX
series

RAMMER

quick manual

Engine Oil
Use SAE 10W/30, SE or higher grade motor oil

RAMMING CYLINDER OIL
Use SAE 10W/30, SF or higher grade motor oil

Fuel
Use normal quality gasoline

A (DECAL SET)

AVS
ANTI-VIBRATION
HANDLE SYSTEM

1900 ~ 2000rpm
3400 ~ 3600rpm
I on → rpm
II off → h

STOP
Mikasa

N

LWA
107dB

LWA
108dB

WARNING
 Operation of this equipment may create sparks that can start fires around dry vegetation. A spark arrester may be required. The operator should contact local fire agencies for laws or regulations relating to fire prevention requirements.

WARNING
 CANCERS
 REPRODUCTIVE
 HARM
 www.mikasa.com
 MPA1214Q

oil fill
 i huille
 di
 olio
 aceite
 SAE30
 25 ~ 30cc
 Check daily
 Kontrolle täglich
 Taglichüberprüfung
 Controllo giornaliero
 Controllo a diario
 Monthly maintenance
 Entretien Mensuel
 Monatsinstandhaltung
 Manutenzione mensile
 Limpieza cada mes
 Mikasa NPA=1246

1900 ~ 2000rpm
3400 ~ 4100rpm
I on → rpm
II off → h

1900 ~ 2000rpm
3400 ~ 3600rpm
I on → rpm
II off → h

1900 ~ 2000rpm
3400 ~ 3700rpm
I on → rpm
II off → h

TAMMING RAMMER / MTX **Mikasa** S3600314Q

NAMEPLATES AND DECALS

<u>NO.</u>	<u>PART NO.</u>	<u>PART NAME</u>	<u>QTY.</u>	<u>REMARKS</u>
A	920900040	DECAL SET	1.....	INCLUDES ITEMS W/#
1	920215440	OPERATION DECAL	1	
2#		DECAL, AIR CLEANER	1	
3#		DECAL, LEVER OPERATION	1	
4#		DECAL, MAX SPEED DECAL, 4100 RPM	1	
5#		DECAL, MACHINE STOP	1	
6#		DECAL, EC NOISE REQ. LWA 107 DB	1	
7#		DECAL, ANTI-VIB HANDLE	1	
8	920212540	QUICK MANUAL	1	
9	920212840	DECAL, CHOKE OPERATION	1	
10	920214100	DECAL, E/G FIRE WARNING	1	
11	920216780	DECAL, EVAPO MEET	1	
12		SERIAL PLATE NO.....	1.....	CONTACT MQ PARTS DEPT. W/SERIAL NO.
13	920222240	DECAL, WARNING PROPOSITION 65	1	

CRANKCASE AND ENGINE ASSY.

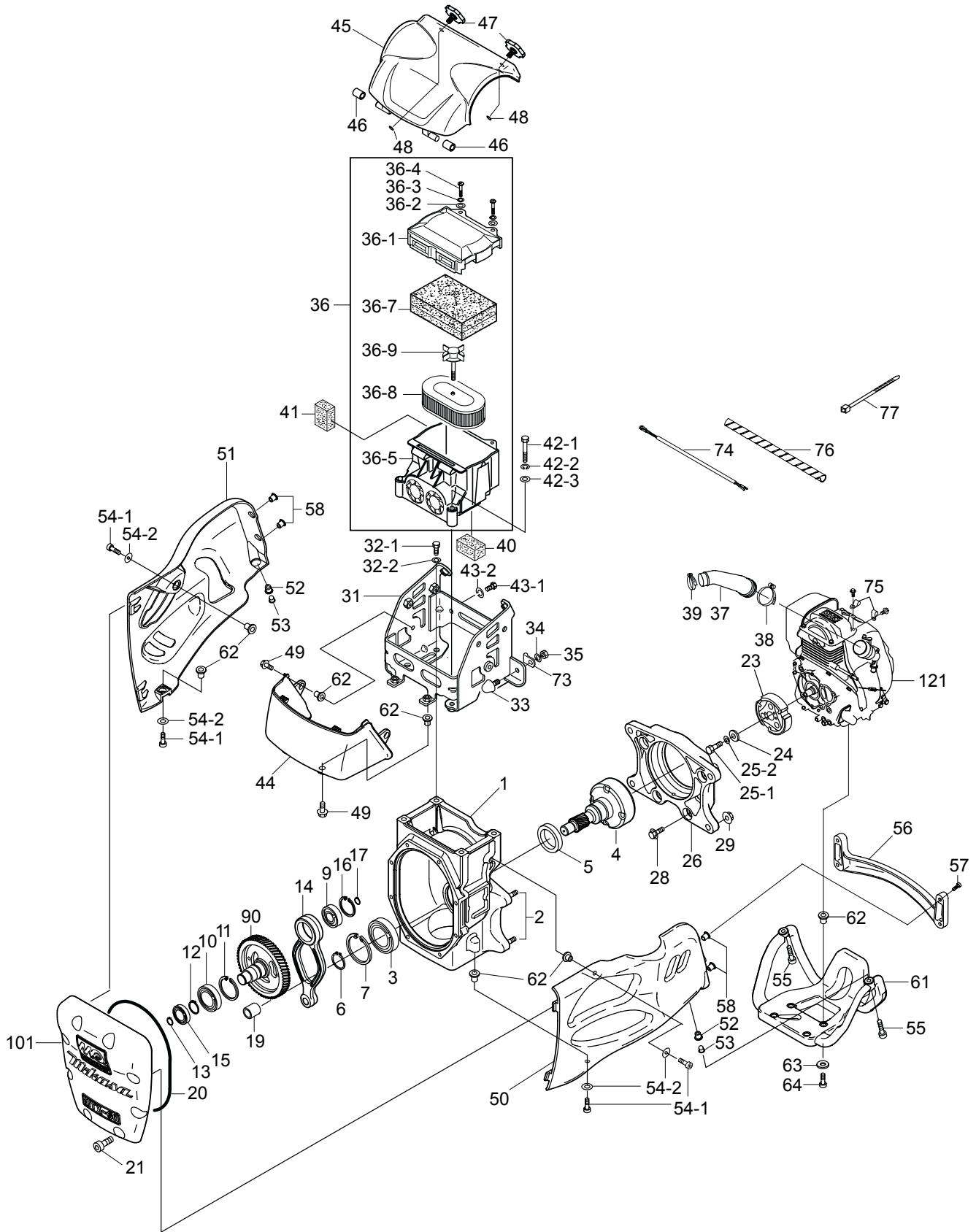

CRANKCASE AND ENGINE ASSY.

<u>NO.</u>	<u>PART NO.</u>	<u>PART NAME</u>	<u>QTY.</u>	<u>REMARKS</u>
1	368910010	CRANKCASE COMPLETE	1	INCLUDES ITEM W/@
2@	009120204	STUD BOLT 10X50X21T/21S	4	
3	041006007	BEARING 6007Z	1	
4	368347410	DRUM, PINION	1	
5	060404010	OIL SEAL TC-40528	1	
6	080200350	STOP RING S-35	1	
7	080100620	STOP RING R-62	1	
9	040006304	BEARING 6304	1	
10	040006305	BEARING 6305	1	
11	080100620	STOP RING R62	1	
12	080200170	STOP RING S-17	1	
13	JISB2804C25	SNAP RING 25MM	1	REPLACES P/N 080200250
14	368347250	CONNECTING ROD	1	
15	042506203	BEARING 6203	1	REPLACES P/N 040006203
16	080100520	STOP RING R-52	1	
17	080200200	STOP RING S-20	1	
19	047940060	NEEDLE BEARING FJ-1816	1	
20	050710100	O-RING AS568-267	1	
21	014208025	SOCKET HEAD BOLT 8X25	8	
23	366348550	CLUTCH ASSY.	1	
24	952401450	WASHER 8.5X22X3	1	
25-1	011208025	BOLT 8X25	1	
25-2	030208200	WASHER, LOCK M8	1	
26	368217640	ENGINE FLANGE	1	
28	001710840	SOCKET HEAD BOLT 8X40	4	
29	022611010	FLANGE NUT, HEX M10	4	
31	368347490	SHOCK ABSORBER BRACKET 60	1	
32-1	012010030	BOLT, HEX 10X30	4	
32-2	030210250	WASHER, LOCK M10	4	
33	939010270	STOPPER RUBBER (70)	1	
34	030208200	WASHER, LOCK M8	1	
35	020108060	NUT M8	1	
36	366900010	AIR CLEANER ASSY.	1	INCLUDES ITEMS W/#
36-1#	366010010	AIR CLEANER COVER	1	
36-2#	366010020	WASHER, FLAT M6 (6.5X18X1.5)	2	
36-3#	030206150	WASHER, LOCK M6	2	
36-4#	366010040	COIN BOLT M6	2	
36-5#	366010050	AIR CLEANER BASE COMPLETE	1	
36-7#	366010070	PRIMARY ELEMENT COMPLETE	1	
36-8#	366010080	SECONDARY ELEMENT	1	
36-9#	362030040	GRIP BOLT COMPLETE	1	
37	366345470	INTAKE PIPE	1	
38	954407681	CYCLONE CLAMP (CY-1) 45	1	
39	954407682	CYCLONE CLAMP (CY-1) 38	1	
40	366460160	UNDER SEALING FORM	1	

CRANKCASE AND ENGINE ASSY. (CONT'D.)

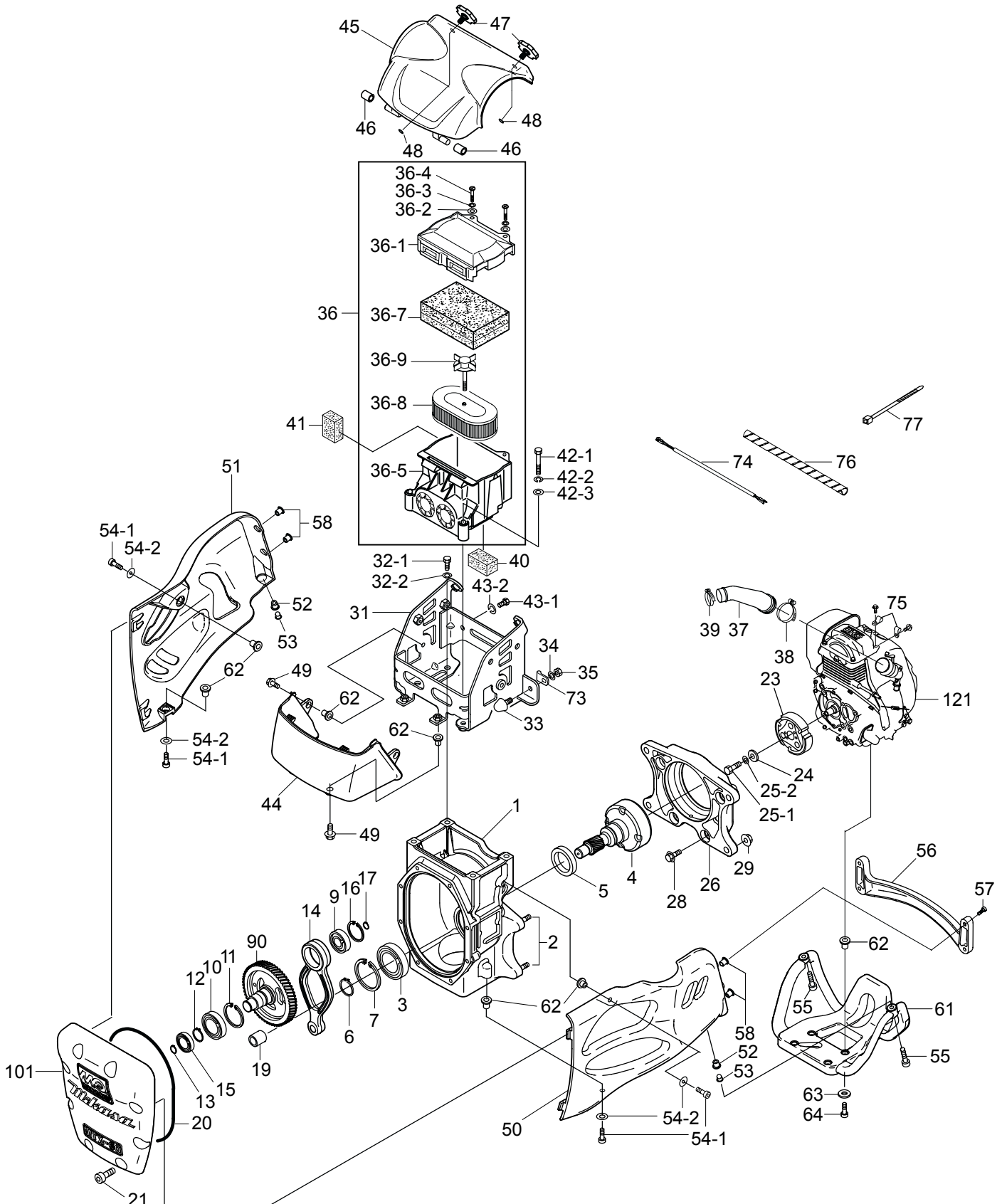

CRANKCASE AND ENGINE ASSY. (CONT'D.)

<u>NO.</u>	<u>PART NO.</u>	<u>PART NAME</u>	<u>QTY.</u>	<u>REMARKS</u>
41	366460150	SIDE SEALING FORM	1	
42-1	001220851	BOLT 8X55	2	
42-2	030208200	WASHER, LOCK M8	2	
42-3	014208020	WASHER, FLAT M8	2	
43-1	011008015	BOLT, HEX 8X15	2	
43-2	030208200	WASHER, LOCK M8	2	
44	368217760	BOTTOM CLEANER COVER 60	1	
45	368217750	TOP CLEANER COVER 60	1	
46	366460140	RUBBER BUSH 10X16X17	2	
47	366345980	CLEANER COVER KNOB	2	
48	050200060	O-RING P6	2	
49	009110040	FLANGE BOLT 8X20	4	
50	368119470	LINK GUARD	1	
51	368119480	MUFFLER GUARD	1	
52	022910260	WELL NUT M8	2	
53	366460170	FLANGE COLLAR 8	2	
54-1	014208020	SOCKET HEAD BOLT 8X20	4	
54-2	033910220	WASHER, FLAT M8	4	
55	009110038	SOCKET HEAD BOLT 8X30	2	
56	368217770	CROSS BAR	1	
57	009110039	SOCKET HEAD BOLT 6X25	4	
58	022910250	WELL NUT M6	4	
61	368119490	ENGINE GUARD	1	
62	366461050	COLLAR/GUARD	12	
63	033910220	WASHER 8.4X15.5X1.6	4	
64	009110038	SOCKET HEAD BOLT 8X30	4	
73	959006120	CLIP	1	
74	368461280	WIRE HARNESS	1	
75	2067550101	CLAMP COMPLETE	2	
76	959021814	SPIRAL TUBE KEP6/L=200	1	
77	454010020	CLAMP TC-100	3	
90	368347270	CRANK GEAR	1	
101	368010010	FRONT COVER	1	
121	912210021	ENGINE ASSY., GX100RTKRBF	1	

GUIDE CYLINDER ASSY.

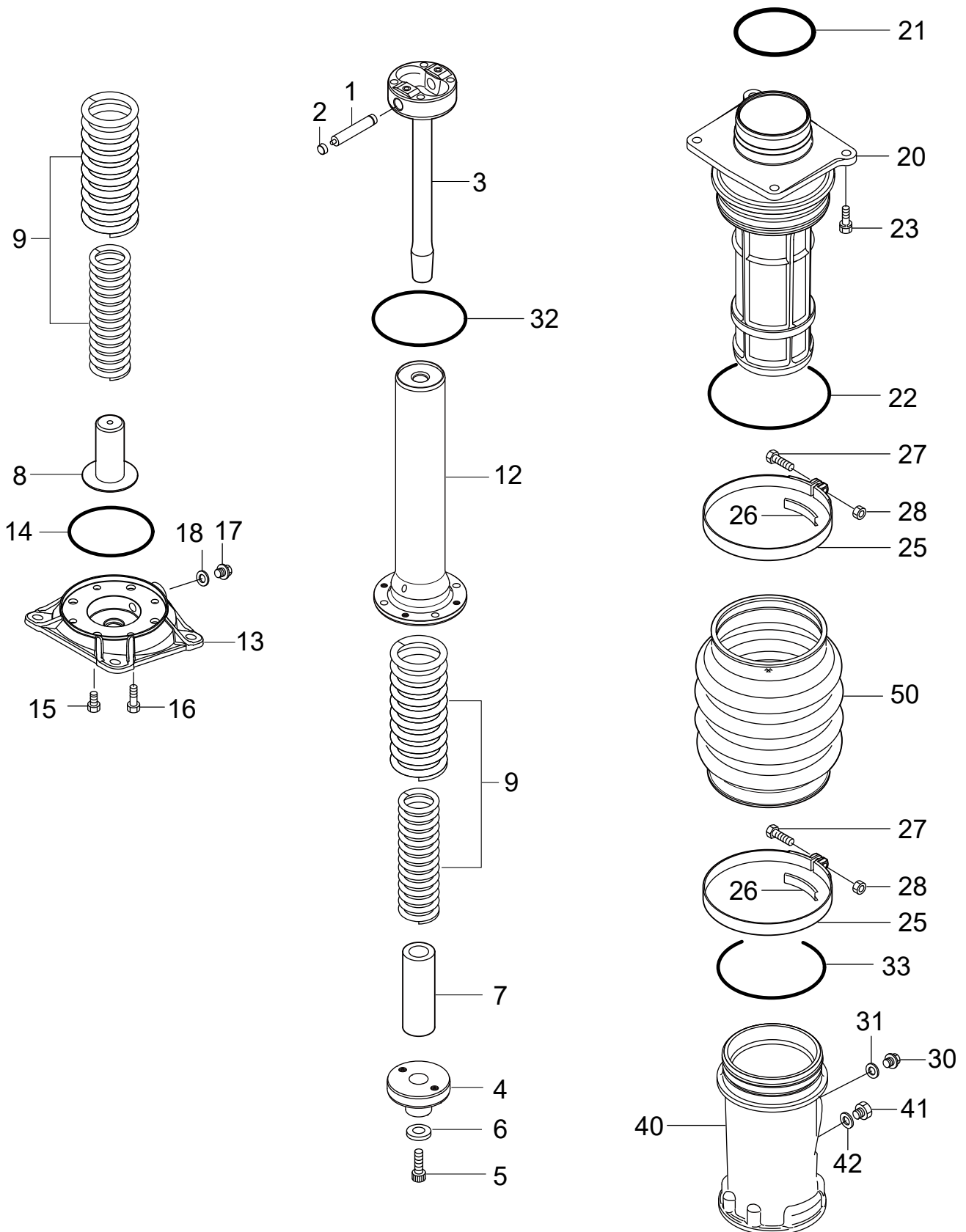

GUIDE CYLINDER ASSY.

<u>NO.</u>	<u>PART NO.</u>	<u>PART NAME</u>	<u>QTY.</u>	<u>REMARKS</u>
1	375471330	PISTON PIN	1	
2	368459920	PISTON PIN PLUG	2	
3	375355840	PISTON ROD	1	
4	375471370	PISTON END	1	
5	009120311	SOCKET HEAD, BOLT 8X35	1	
6	952409980	WASHER 8.5X20X4.5	1	
7	375471420	LOWER STOPPER	1	
8	375471410	BOTTOM STOPPER	1	
9	375471430	MAIN SPRING	2	
12	375355830	SPRING CYLINDER	1	
13	375219970	FOOT PLATE	1	
14	050100700	O-RING	1	
15	001520815	SOCKET HEAD BOLT 8X15	4	
16	001520830	SOCKET HEAD BOLT 8X30	4	
17	953405270	PLUG 1/4X14 13L	1	
18	953405260	PACKING 1/4	1	
20	375122540	CYLINDER GUIDE	1	
21	050100850	O-RING G-85	1	
22	050100950	O-RING G-95	1	
23	002211035	BOLT, HEX 10X35, WASHER, LOCK	4	
25	351316870	BELLOWS CLAMP	2	
26	351433250	BAND GUIDE	2	
27	001220835	BOLT 8X35	2	
28	020308060	NUT M8	2	
30	953405270	PLUG 1/4X14 13L	1	
31	953405260	PACKING 1/4	1	
32	050200700	O-RING P-70	1	
33	050100950	O-RING G-95	1	
40	375122530	PROTECTION SLEEVE	1	
41	366460300	OIL GAUGE ASSY.	1	
42	953404670	COPPER PACKING 17X25.5X1	1	
50	353332870	ORANGE BELLOWS	1	

FOOT ASSY.

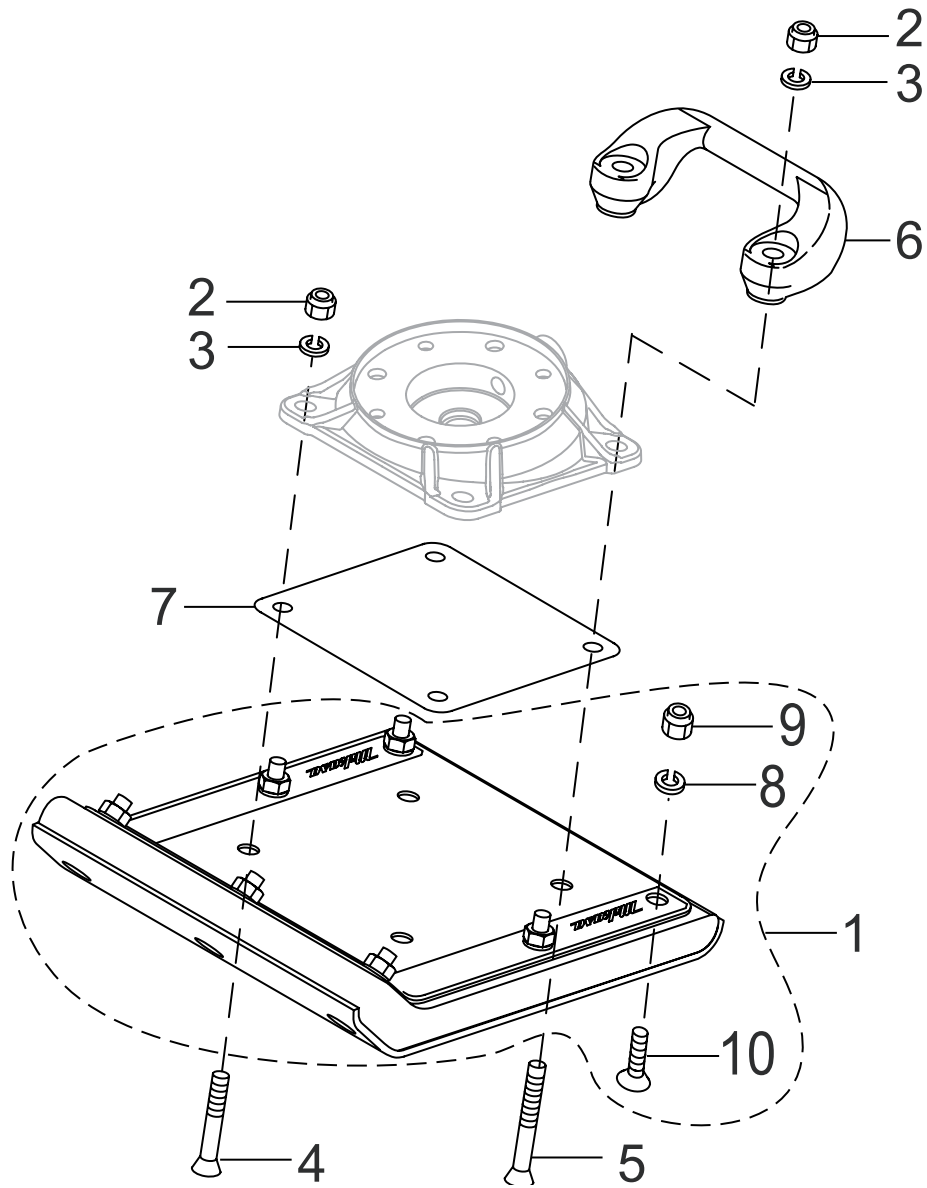

FOOT ASSY.

<u>NO.</u>	<u>PART NO.</u>	<u>PART NAME</u>	<u>QTY.</u>	<u>REMARKS</u>
1	362910150	FOOT ASSY., 265W.....	1.....	INCLUDES ITEMS W/#
2	022711214	NYLON NUT M12	4	
3	030212300	WASHER, LOCK M12	4	
4	009110034	BOLT, SQUARE NECK 12X65	2	
5	009110035	BOLT, SQUARE NECK 12X95	2	
6	363343390	HANDLE LIFT	1	
7	368347460	FOOT COVER	1	
8#	030210250	WASHER, LOCK M10	7	
9#	022711012	NYLON NUT M10	7	
10#	009110036	BOLT, SQUARE NECK 10X55	7	

FUEL TANK AND HANDLE ASSY.

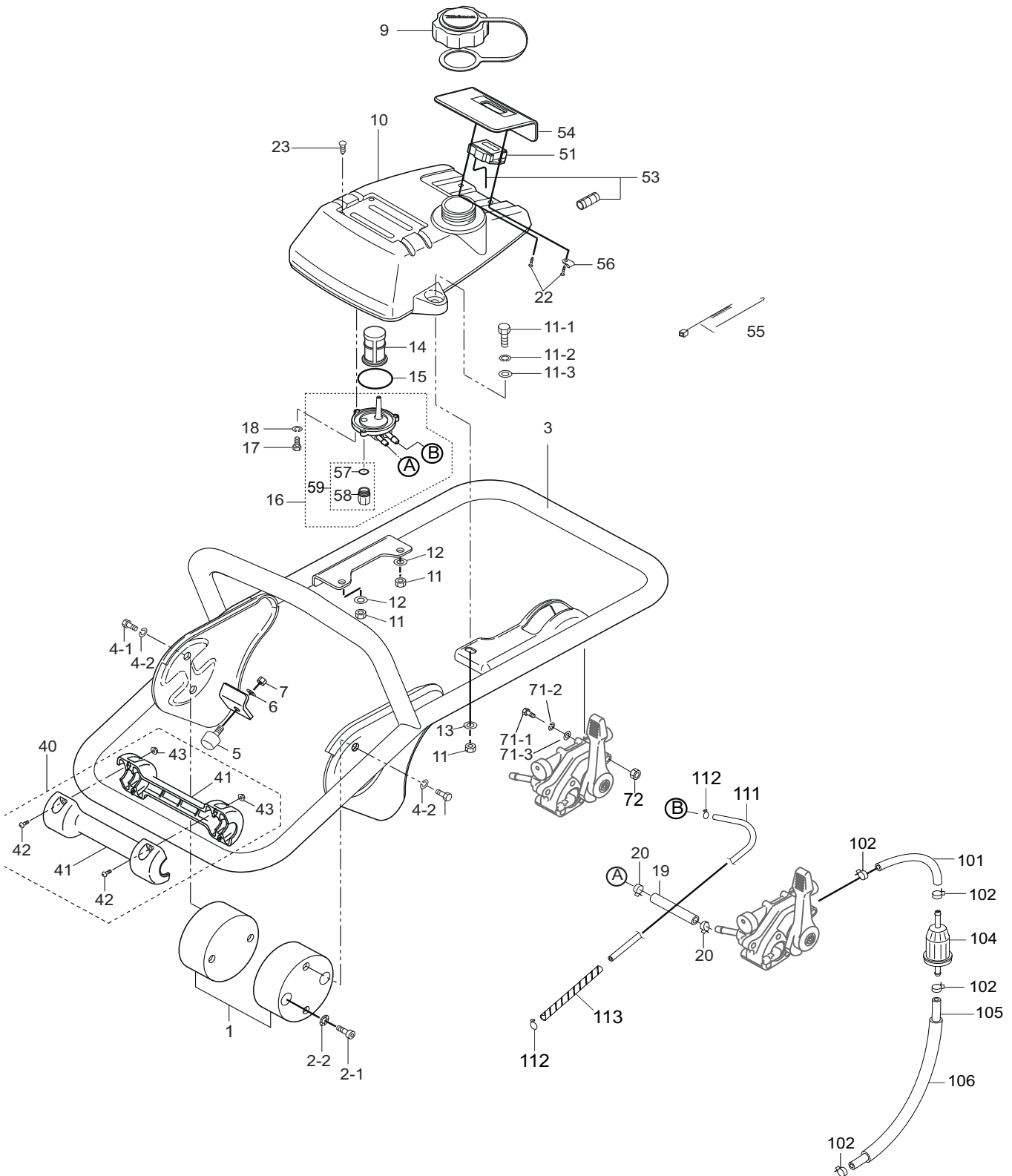

FUEL TANK AND HANDLE ASSY.

<u>NO.</u>	<u>PART NO.</u>	<u>PART NAME</u>	<u>QTY.</u>	<u>REMARKS</u>
1	368347630	SHOCK ABSORBER	2	
2-1	014210020	SOCKET HEAD BOLT 10X20	4	
2-2	033121009	TOOTHED LOCK WASHER B M10	4	
3	368119572	HANDLE	1	
4-1	001211020	BOLT, HEX 10X20	4	
4-2	030210250	WASHER, LOCK M10	4	
5	939010270	STOPPER, RUBBER	1	
6	030208200	WASHER, LOCK M8	1	
7	020108060	NUT M8	1	
9	366350460	CAP ASSY., FUEL TANK	1	
10	366120250	FUEL TANK	1	
11	022710809	NYLON NUT M8	3	
11-1	011208025	BOLT, HEX 8X25	3	
11-2	030208200	WASHER, LOCK M8	3	
11-3	0401450080	WASHER, FLAT M8.....	3	REPLACES P/N 401450080
12	952401450	WASHER, 8.5X22X3	2	
13	0401450080	WASHER, FLAT M8.....	1	REPLACES P/N 401450080
14	954406010	STRAINER	1	
15	050250420	O-RING	1	
16	366350110	HOLDER, FILTER.....	1	INCLUDES ITEMS W/\$
17	001200515	BOLT, HEX 5X15	3	
18	030205130	WASHER, LOCK M5	3	
19	366900110	FUEL HOSE, L=90.....	1	REPLACES P/N 959328406
20	954406420	HOSE BAND 10.5	2	
22	009110037	TAPPING SCREW 5X20	2	
23	094010053	PAN HEAD SCREW 4X8	4	
40	366910030	ROLLER ASSY. W/SCREW.....	1	INCLUDES ITEMS W/#
41#	366217170	ROLLER	2	
42#	017105020	SCREW 5X20	4	
43#	022610505	FLANGE NUT HEX M5	4	
51	955010311	TACH/HOUR METER	1	
53	955010305	CURL CORD	1	
54	366345620	FINISHER, METER	1	
55	454010020	CLAMP	5	
56	954010270	CLIP	1	
57\$&	366464270	PACKING, HOLDER FILTER	1	
58\$&	366464260	CUP, HOLDER FILTER	1	
59\$	366900170	CUP AND PACKING SET.....	1	INCLUDES ITEMS W/&
71-1	011206020	BOLT 6X20	2	
71-2	030206150	WASHER, LOCK M6	2	
71-3	031106100	WASHER, FLAT M6	2	
72	020106050	NUT M6	2	
101	91434Z4E812	HOSE, FUEL 5.5X11.5X80	1	
102	0561080020	CLAMP, HOSE	4	
104	16910Z4ES21	FILTER, IN-LINE FUEL	1	
105	91434Z4E902	HOSE, FUEL 4.5X330	1	
106	950033600110M	TUBE, VINYL L260.....	1	REPLACES P/N 950033606020
111	959028301	RETURN HOSE 3X6X600	1	
112	954408170	HOSE CLIP	2	
113	959021814	SPIRAL TUBE	1	

COMBINATION LEVER ASSY.

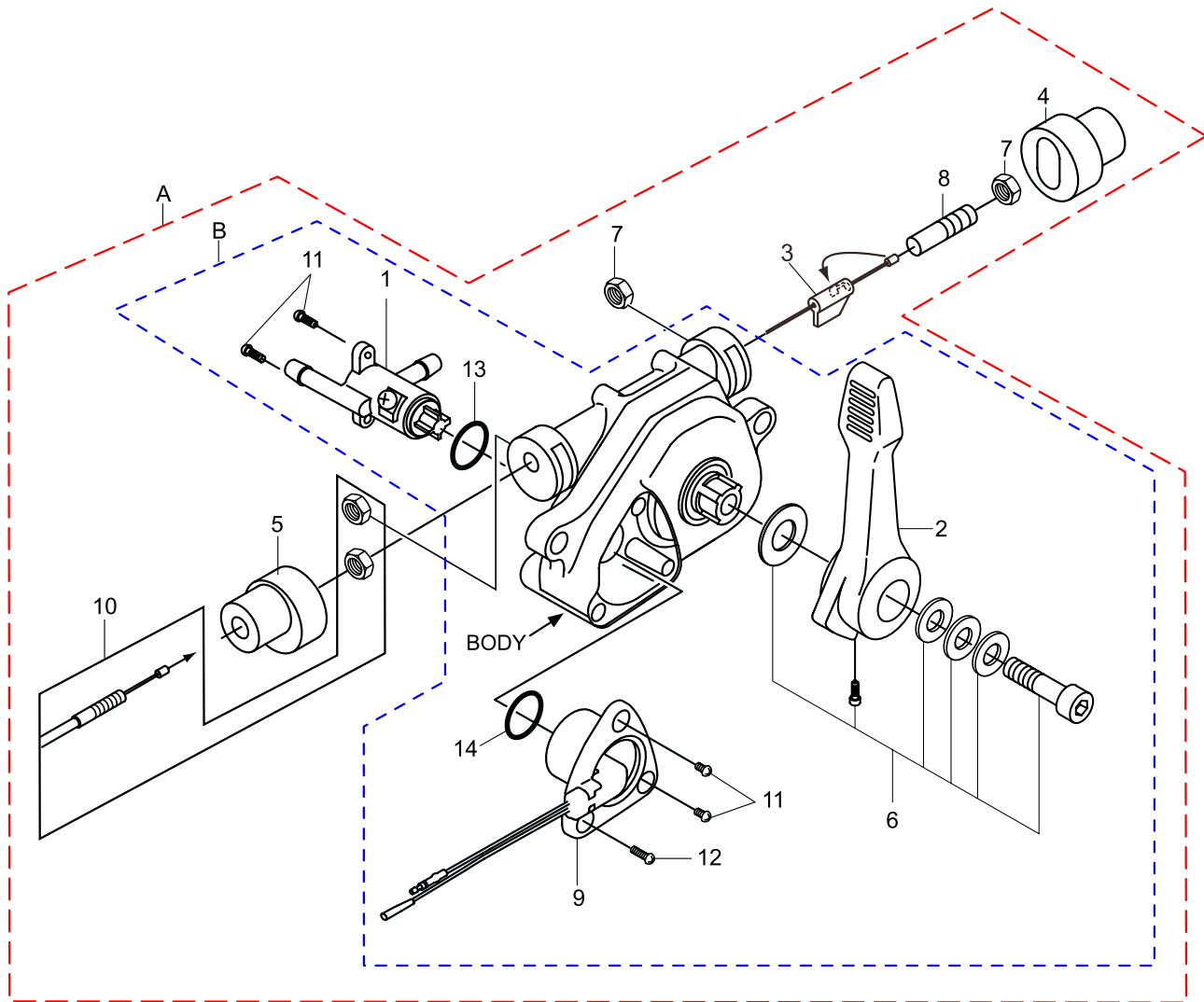

COMBINATION LEVER ASSY.

<u>NO.</u>	<u>PART NO.</u>	<u>PART NAME</u>	<u>QTY.</u>	<u>REMARKS</u>
A	366900032	COMB. LEVER W/ THROTTLE WIRE.....	1.....	INCLUDES ITEMS W/@
B	956200110	COMB. LEVER W/OUT THROTTLE WIRE	1.....	INCLUDES ITEMS W/ #
1@#	366349430	FUEL COCK	1	
2@#	366010310	LEVER	1	
3@	366010190	SLIDER	1	
4@	366010200	END CAP	1	
5@	366010210	WIRE CAP	1	
6@#	366010220	BOLT AND WASHER SET	1	
7@	020408050	NUT M8, H=5	2	
8@	959407650	SOCKET HEAD SCREW/TH.WIRE	1	
9@#	366010320	STOP SWITCH	1	
10@	956100062	THROTTLE WIRE	1	
11@#	094010051	TAPPING SCREW B1 4X12	4	
12@#	094010052	TAPPING SCREW B1 4X30	1	
13@#	050200150	O-RING, P15	1	
14@#	050200110	O-RING, P11	1	

TOOLS ASSY.

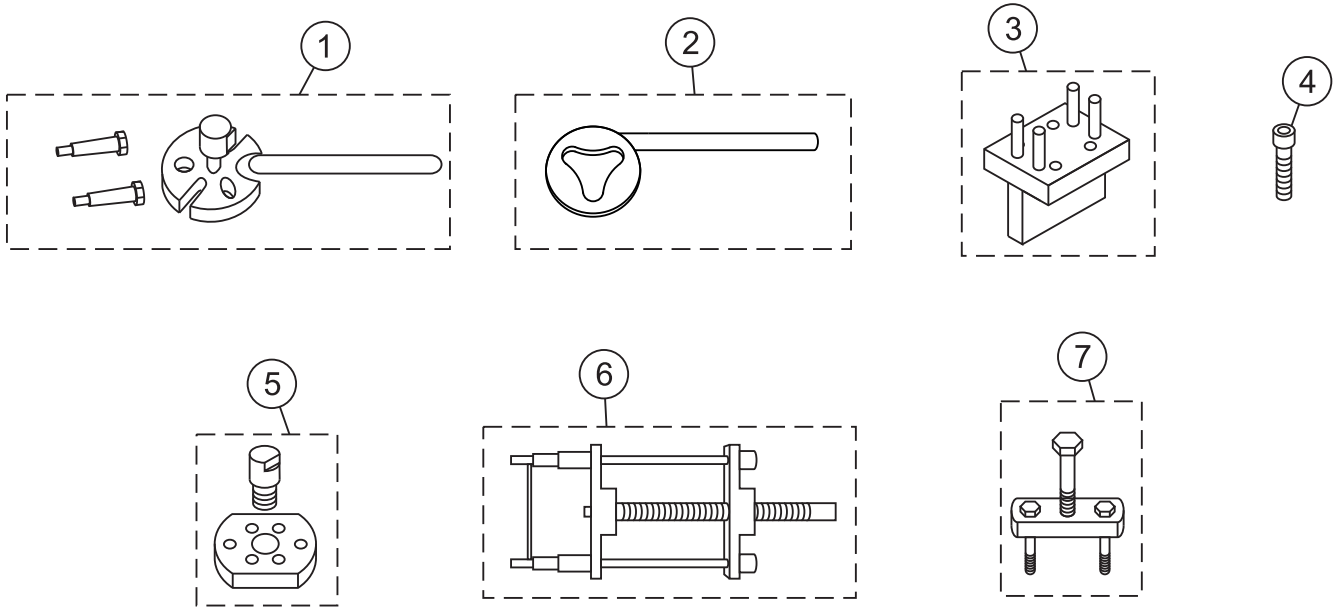

TOOLS ASSY.

<u>NO.</u>	<u>PART NO.</u>	<u>PART NAME</u>	<u>QTY.</u>	<u>REMARKS</u>
1	983010090	CLUTCH PULLER A	1	
2	983010060	CLUTCH MOUNTER	1	
3	983910050	PISTON ROD HOLDER	1	
4	009110044	SOCKET HD BOLT 8X50 (FULL THREAD).....	2.....	CRANK GEAR REMOVER
5	983910021	CLUTCH PULLER B	1.....	NO LONGER AVAILABLE
6	983010080	SPRING REMOVER M8	1	
7	983910060	PISTON END REMOVER	1	

GX100RTKRF ENG. — CYLINDER BARREL ASSY.

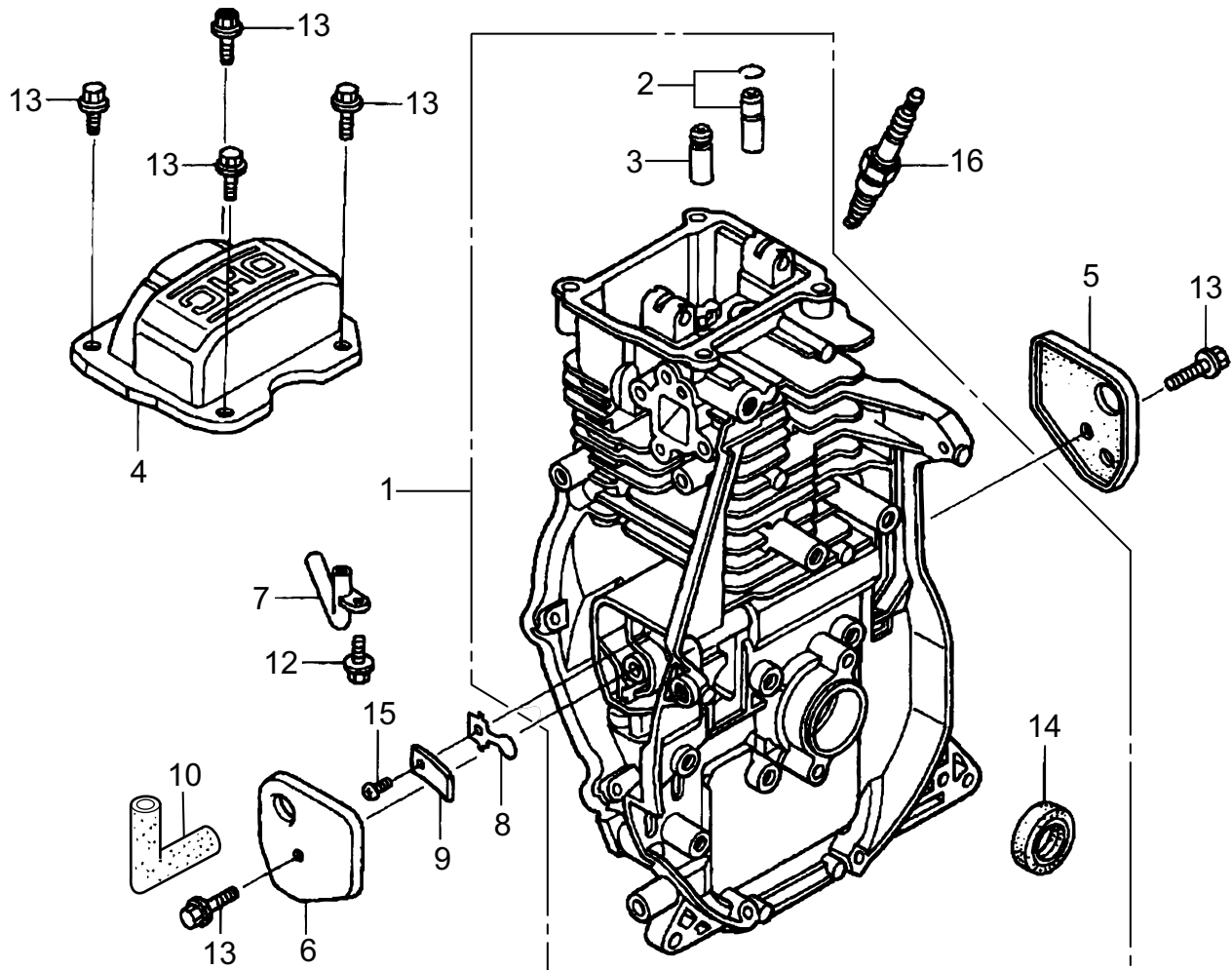

GX100RTKRB ENG. — CYLINDER BARREL ASSY.

<u>NO.</u>	<u>PART NO.</u>	<u>PART NAME</u>	<u>QTY.</u>	<u>REMARKS</u>
1	12000Z0D405	BARREL ASSY., CYLINDER.....	1.....	INCLUDES ITEMS W/\$
2\$	12201Z0D305	GUIDE ASSY., EXHAUST VALVE (O.S.)	1	
3\$	12204Z0D305	GUIDE, INLET VALVE (O.S.)	1	
4	12311Z0D000	COVER, HEAD	1	
5	12355Z0D000	COVER COMPLETE A, BREATHER	1	
6	12365Z0D000	COVER COMPLETE B, BREATHER	1	
7	15171Z0DV00	PIPE, BREATHER	1	
8	15571Z0DV71	VALVE, OIL OUTLET	1	
9	15572ZM7000	PLATE, STOPPER	1	
10	15721Z0DV70	TUBE, BREATHER	1	
12	90008ZM7000	BOLT 4X10	1	
13	90014952000	BOLT, FLANGE 6X14	6	
14\$	91202KJ9003	OIL SEAL 20X32X6	1	
15	93500030050A	SCREW, PAN 3X5	1	
16	9805655777	SPARK PLUG (CR5HSB)	1	

GX100RTKRBF ENG. — CRANKCASE COVER ASSY.

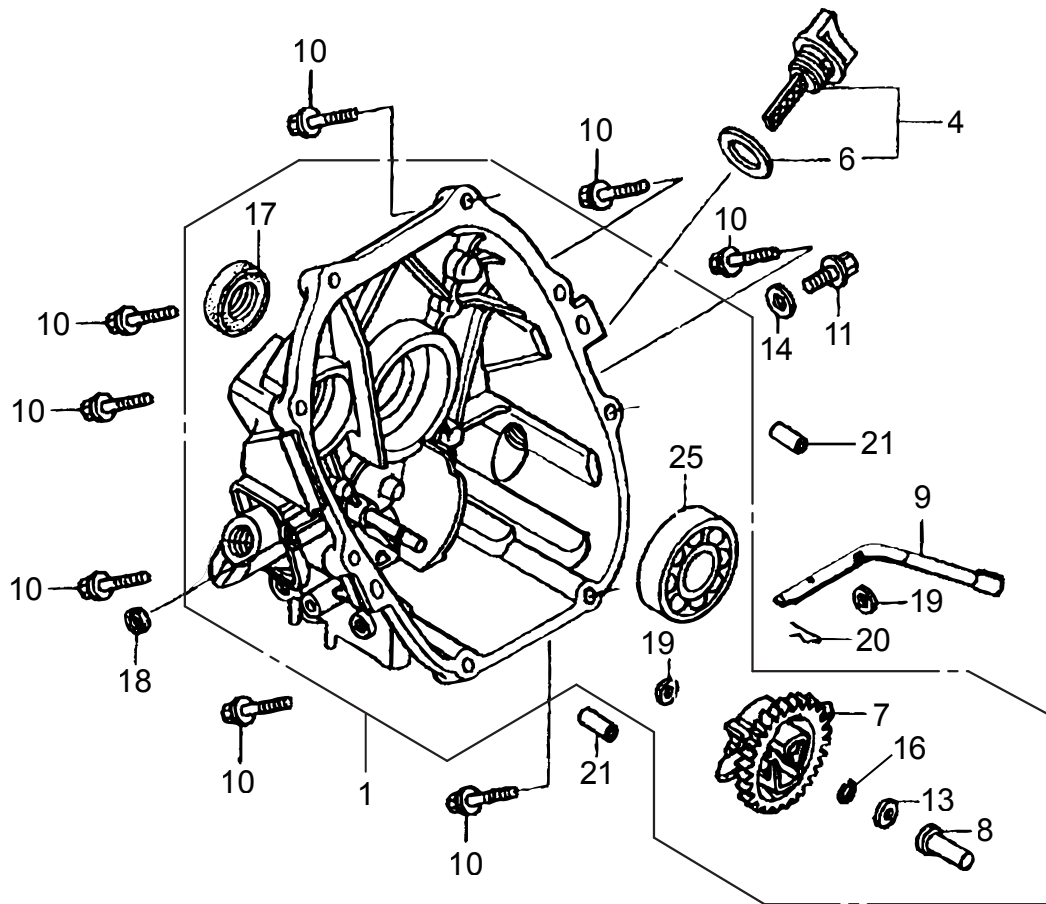

GX100RTKRBF ENG. — CRANKCASE COVER ASSY.

<u>NO.</u>	<u>PART NO.</u>	<u>PART NAME</u>	<u>QTY.</u>	<u>REMARKS</u>
1	11300Z0D409	COVER ASSY., CRANK CASE.....	1.....	INCLUDES ITEMS W/#
4	15600ZDF000	CAP ASSY., OIL FILLER.....	1.....	INCLUDES ITEMS W/\$
6\$	15625Z0T800	PACKING, OIL FILLER CAP	1	
7#	16510ZL8000	GOVERNOR ASSY.	1	
8#	16531ZE1000	SLIDER, GOVERNOR	1	
9	16541Z0D000	SHAFT, GOVERNOR ARM	1	
10	957010602500	FLANGE BOLT 6X25	8.....	REPLACES P/N 90121952000
11	90131ZE1000	BOLT, DRAIN PLUG	1	
13#	90451ZE1000	THRUST WASHER 6MM	1	
14	90601ZE1000	WASHER, DRAIN PLUG	1	
16#	90602ZE1000	CLIP, GOVERNOR HOLDER	1	
17#	91202KJ9003	OIL SEAL 20X32X6	1	
18	91231891003	OIL SEAL 6X11X4	1	
19#	58176	WASHER, FLAT 6MM.....	2.....	REPLACES P/N 9410106800
20	9425108000	LOCK PIN 8MM	1	
21	9430108200	KNOCK PIN 8X20	2	
25#	91001Z0DV01	BEARING, RADIAL BALL	1	

GX100RTKRBF ENG. — CRANKSHAFT ASSY.

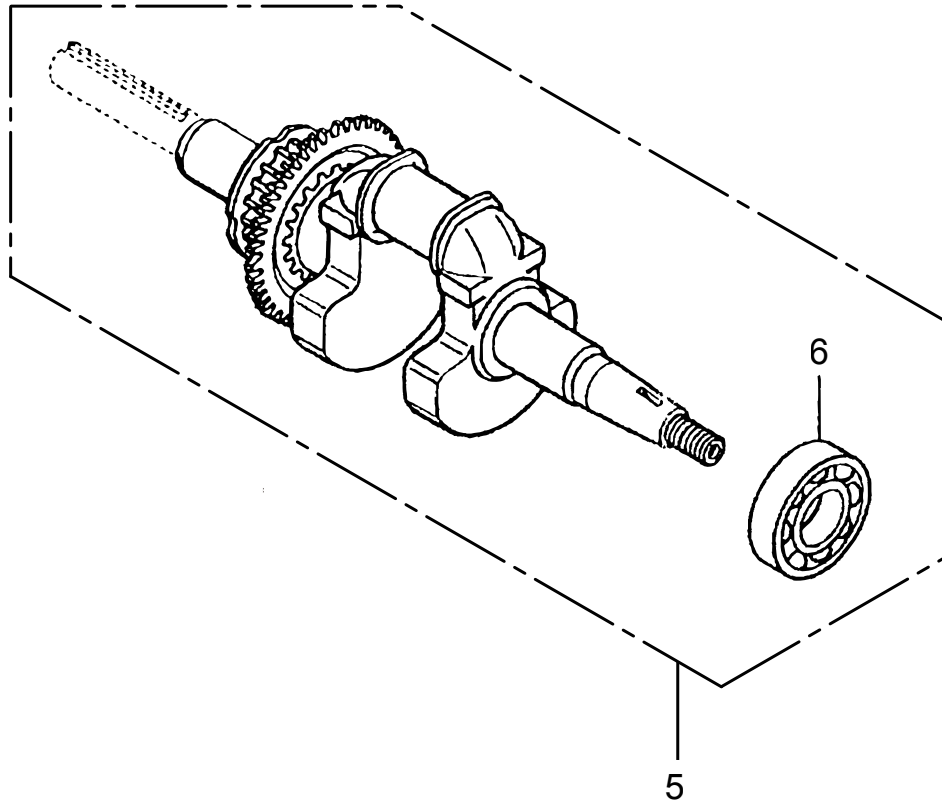

GX100RTKRBF ENG. — CRANKSHAFT ASSY.

<u>NO.</u>	<u>PART NO.</u>	<u>PART NAME</u>	<u>QTY.</u>	<u>REMARKS</u>
5	13310Z0DV70	CRANK SHAFT COMPLETE	1.....	INCLUDES ITEM W/\$
6\$	91001Z0DV01	BEARING, RADIAL BALL	1	

GX100RTKRBF ENG. — PISTON/CONN. ROD ASSY.

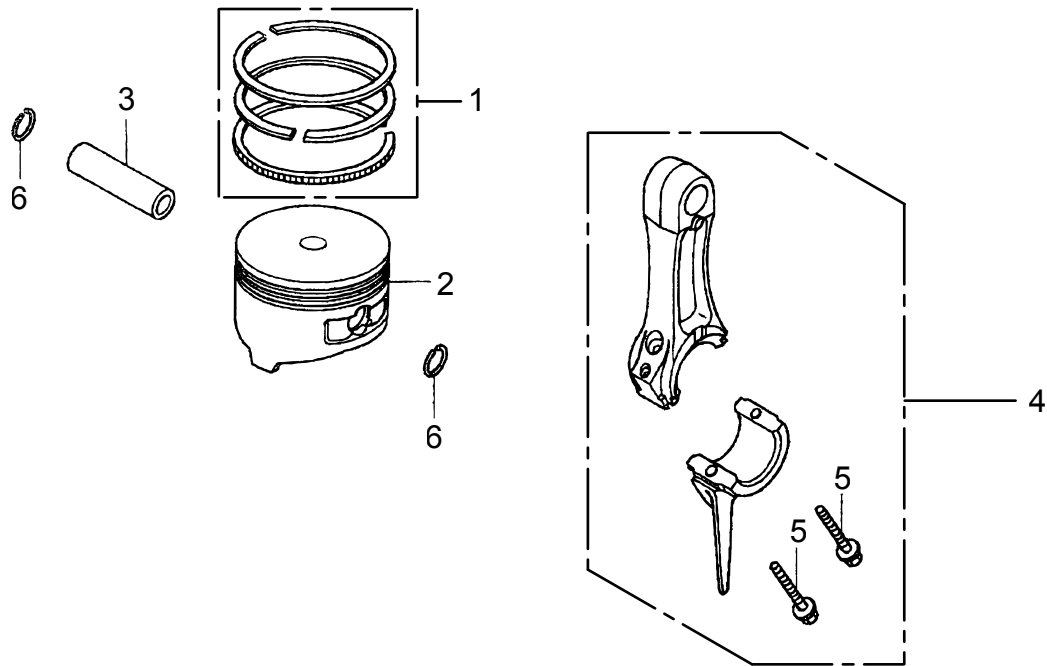

GX100RTKRBF ENG. — PISTON/CONN. ROD ASSY.

<u>NO.</u>	<u>PART NO.</u>	<u>PART NAME</u>	<u>QTY.</u>	<u>REMARKS</u>
1	13010Z0D003	RING SET, PISTON	1	
2	13101Z0D000	PISTON	1	
3	13111ZE0000	PISTON PIN	1	
4	13200Z0D000	CONNECTING ROD ASSY.....	1.....	INCLUDES ITEM W/#
5#	90001ZM7000	CONNECTING ROD BOLT	2	
6	90551ZE0000	CLIP, PISTON PIN 13MM	2	

GX100RTKRB ENG. — CAMSHAFT PULLEY ASSY.

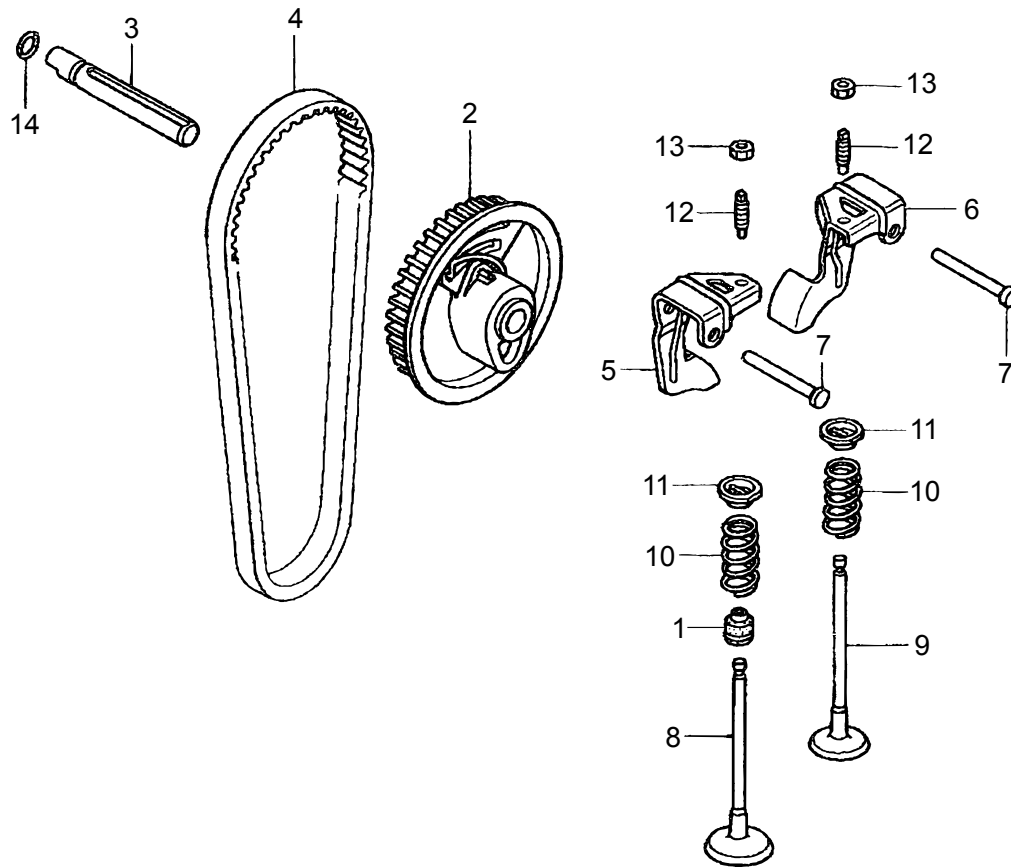

GX100RTKRBF ENG. — CAMSHAFT PULLEY ASSY.

<u>NO.</u>	<u>PART NO.</u>	<u>PART NAME</u>	<u>QTY.</u>	<u>REMARKS</u>
1	12209KT7013	SEAL, VALVE STEM	1	
2	14320ZDD000	PULLEY COMP., CAMSHAFT/RTE	1	
3	14324Z0D000	SHAFT, CAM PULLEY	1	
4	14400Z0D003	TIMING BELT	1	
5	14431ZDD000	ROCKER ARM, INTAKE VALVE	1	
6	14441ZDD000	ROCKER ARM, EXHAUST VALVE	1	
7	14461ZL8000	SHAFT, ROCKER ARM	2	
8	14711Z0D000	INLET VALVE	1	
9	14721Z0D000	EXHAUST, VALVE	1	
10	14751Z0D000	SPRING, VALVE	2	
11	14771ZM3010	RETAINER, VALVE SPRING	2	
12	90012333000	SCREW, TAPPET ADJUSTING	2	
13	90206001000	NUT, TAPPET ADJUSTING	2	
14	91301ZM0V31	O-RING 6.8X1.9	1	

GX100RTKRBF ENG. — RECOIL STARTER ASSY.

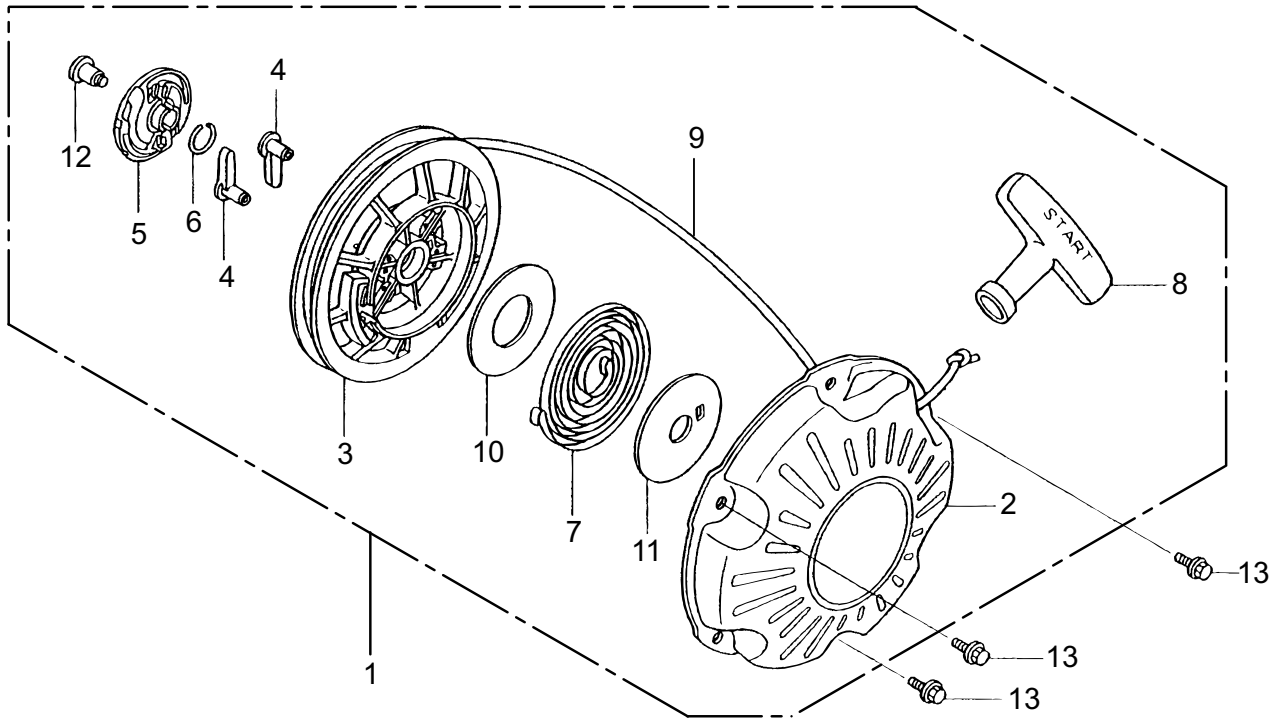

GX100RTKRBF ENG. — RECOIL STARTER ASSY.

<u>NO.</u>	<u>PART NO.</u>	<u>PART NAME</u>	<u>QTY.</u>	<u>REMARKS</u>
1	28400Z0DV04ZA	RECOIL STARTER ASSY.	1.....	INCLUDES ITEMS W/\$
2\$	28410Z0DV02ZA	CASE COMPLETE/RECOIL *5-3-5(B)	1	
3\$	28421ZDD003	REEL, RECOIL STARTER	1	
4\$	28422ZG0W02	RATCHET, STARTER	2	
5\$	28433ZG0W02	GUIDE, RATCHET	1	
6\$	28441ZW9003	SPRING, FRICTION	1.....	REPLACES P/N 28441ZW6003
7\$	28442ZH8003	SPRING, RECOIL STARTER	1	
8\$	28461ZDD003	KNOB, RECOIL STARTER	1	
9\$	28462Z0DV03	ROPE, RECOIL STARTER	1	
10\$	28467Z0DV02	PLATE, SIDE	1	
11\$	28468Z0DV02	PLATE, SLIDE	1	
12\$	90003ZH8003	SET SCREW	1	
13	957010600800	FLANGE BOLT 6X8	3	

GX100RTKRBF ENG. — FAN COVER ASSY.

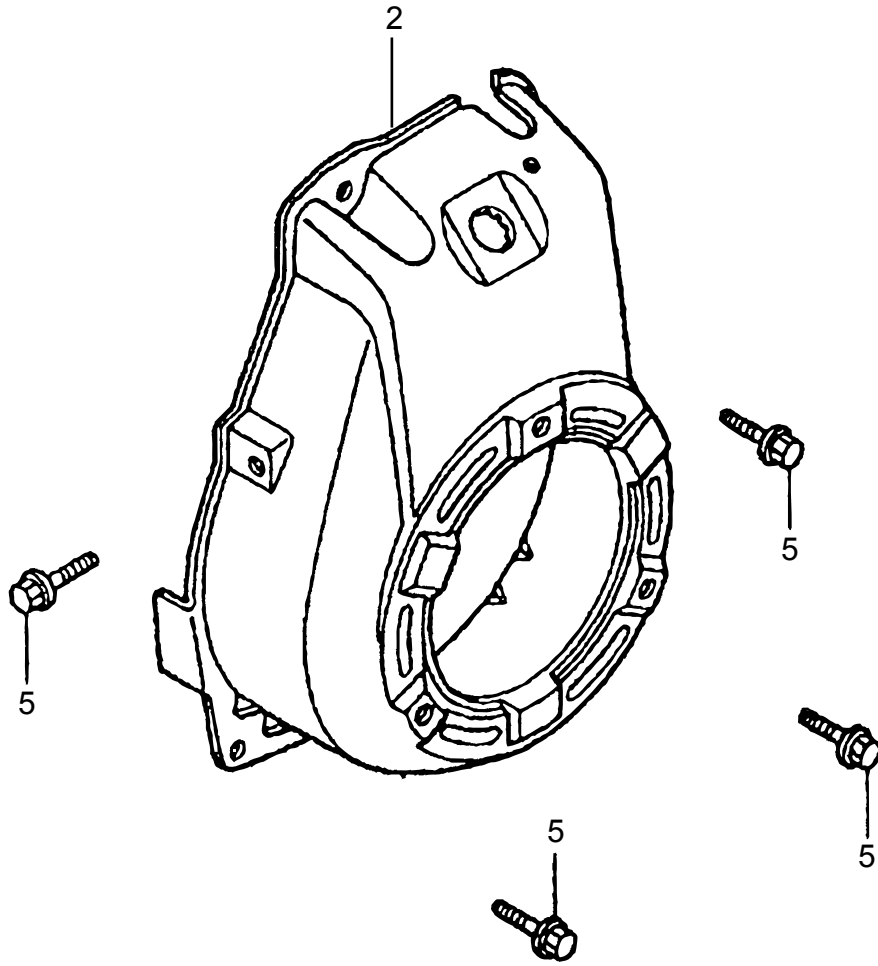

GX100RTKRBFB ENG. — FAN COVER ASSY.

<u>NO.</u>	<u>PART NO.</u>	<u>PART NAME</u>	<u>QTY.</u>	<u>REMARKS</u>
2	19610Z4ES30ZA	FAN COVER COMPLETE, BLK.	1	
5	90014952000	BOLT, FLANGE 6X14	4	

GX100RTKRB ENG. — CARBURETOR ASSY.

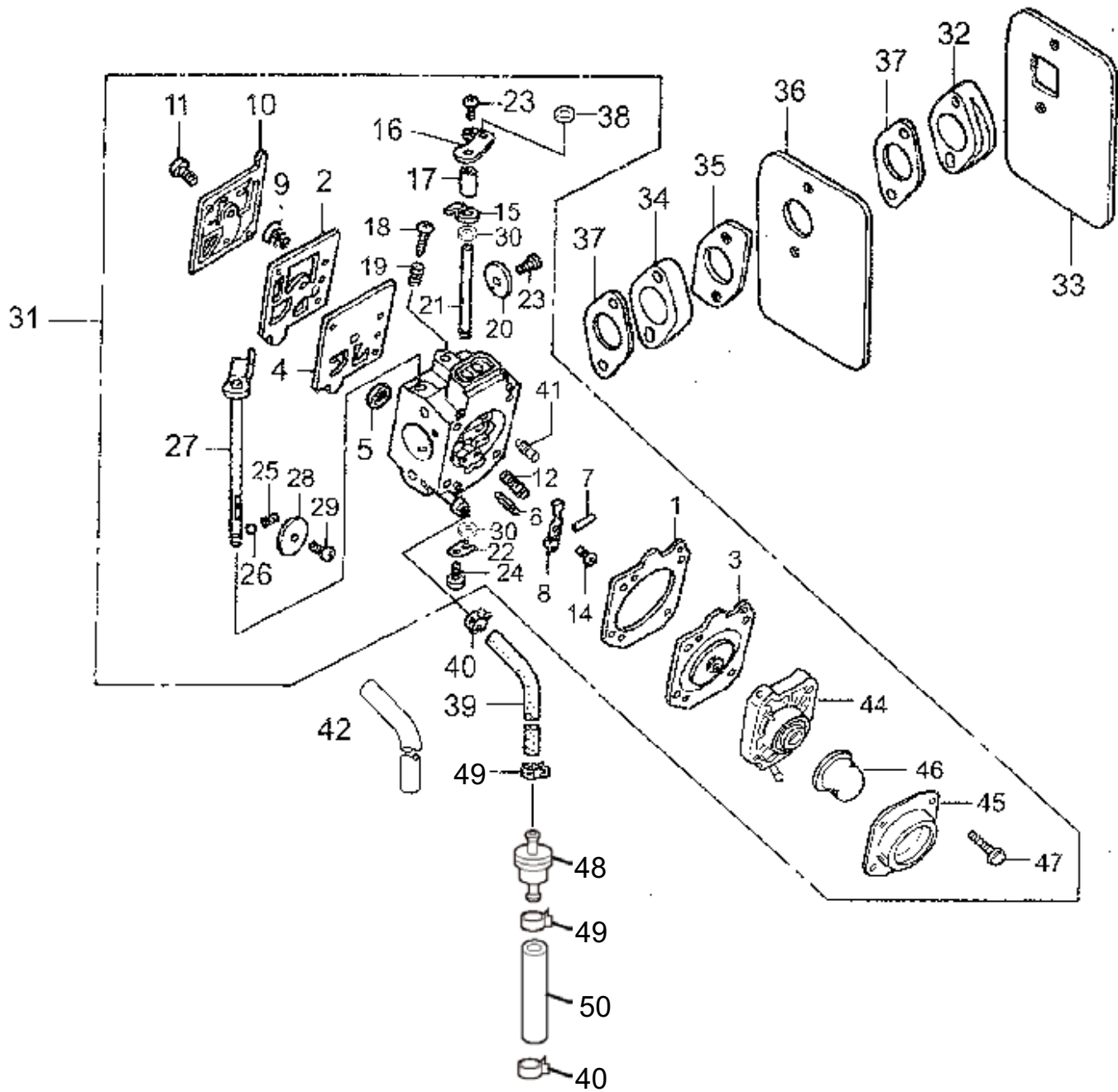

GX100RTKRFB ENG. — CARBURETOR ASSY.

<u>NO.</u>	<u>PART NO.</u>	<u>PART NAME</u>	<u>QTY.</u>	<u>REMARKS</u>
1\$	16010Z0DV02	GASKET, METERING DIAPHRAGM	1	
2\$	16011Z0DV02	GASKET, PUMP	1	
3\$	16013Z4ES44	DIAPHRAGM ASSY., METERING/RT	1	
4\$	16014Z0DV02	DIAPHRAGM, PUMP	1	
5\$	16018ZM3004	SCREEN, INLET	1	
6\$	16019ZM3004	VALVE, INLET NEEDLE	1	
7\$	16022ZM3014	PIN, METERING LEVER	1	
8\$	16023Z0DV02	LEVER, METERING	1	
9\$	16030ZM3004	SPRING, PUMP	1	
10\$	16040Z4E802	COVER, PUMP	1	
11\$	16041Z0DV02	SCREW	1	
12\$	16042Z0DV02	SPRING	1	
14\$	16044Z4E802	SCREW	1	
15\$	16045Z0DV02	STOPPER, THROTTLE LEVER	1	
16\$	16046Z0DV73	LEVER, THROTTLE	1	
17\$	16048Z0DV02	SPACER, THROTTLE LEVER	1	
18\$	16049Z4ES12	SCREW, IDLE ADJUSTING	1	
19\$	16050Z0DV02	SPRING	1	
20\$	16051Z4ES44	VALVE, THROTTLE	1	
21\$	16052Z0DV02	SHAFT, THROTTLE	1	
22\$	16053Z0DV02	CLIP, THROTTLE SHAFT	1	
23\$	16054Z0DV02	SCREW, VALVE	2	
24\$	16055Z0DV02	SCREW ASSY.	1	
25\$	16056Z0DV02	SPRING	1	
26\$	16057Z0DV02	BALL	1	
27\$	16058Z0DV02	SHAFT, ASSY., CHOKE	1	
28\$	16059Z0DV03	VALVE, CHOKE	1	
29\$	16060Z0DV02	SCREW	1	
30\$	16061Z0DV02	SEAL, DUST	2	
31	16100Z4ES46	CARBURETOR ASSY. (W/PRIMER)	1	INCLUDES ITEMS W/\$
32	16211Z0DV01	INSULATOR, CARBURETOR	1	
33	16212Z0DV00	PACKING, INSULATOR	1	
34	16213Z4ES10	INSULATOR B, CARBURETOR	1	
35	16214Z0DV00	PACKING B, INSULATOR	1	REPLACES P/N 16214Z0DV01
36	16215Z0DV00	PLATE, INSULATOR	1	
37	16221Z0DV00	PACKING, CARBURETOR	2	
38\$	16552896650	COLLAR, LEVER	1	
39	91434Z4E902	HOSE, FUEL 4.5X330	1	
40	H950024085008	CLAMP, TUBE	2	REPLACES P/N 950024085008
41\$	99101Z0D0460	JET (#46)	1	
41\$	99101Z0D0480	JET (#48)	1	
41\$	99101Z0D0500	JET (#50)	1	
41\$	99101Z0D0520	JET (#52)	1	
42	950033602620	TUBE, VINYL 11X13X260	1	
44\$	16017Z4ES32	BODY ASSY., AIR PURGE	1	
45\$	16026Z4ES32	COVER, PRIMER PUMP	1	
46\$	16032Z4ES32	PUMP, PRIMER	1	
47\$	16055Z4ES32	SCREW ASSY.	4	
48	16910Z4ES21	STRAINER, FUEL	1	
49	90602Z4E003	CLAMP, TUBE	2	
50	91434Z4E812	HOSE, FUEL 4.5X80	1	

GX100RTKRBF ENG. — ELBOW AIR CLEANER ASSY.

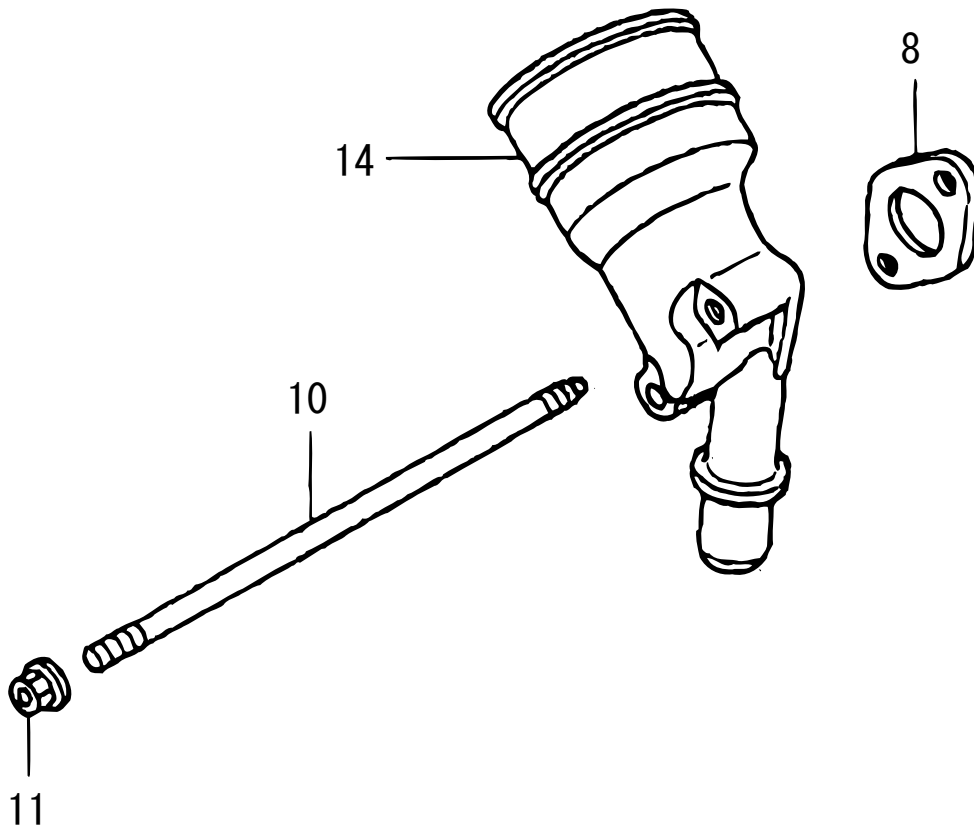

GX100RTKRBF ENG. — ELBOW AIR CLEANER ASSY.

<u>NO.</u>	<u>PART NO.</u>	<u>PART NAME</u>	<u>QTY.</u>	<u>REMARKS</u>
8	17228Z0DV01	PACKING, AIR CLEANER	1	
10	90042Z4ES30	BOLT, STUD 5X95	2	
11	9405005000	NUT, FLANGE 5MM	2	
14	17410Z4ES31	ELBOW, AIR CLEANER	1	

GX100RTKRB ENG. — MUFFLER ASSY.

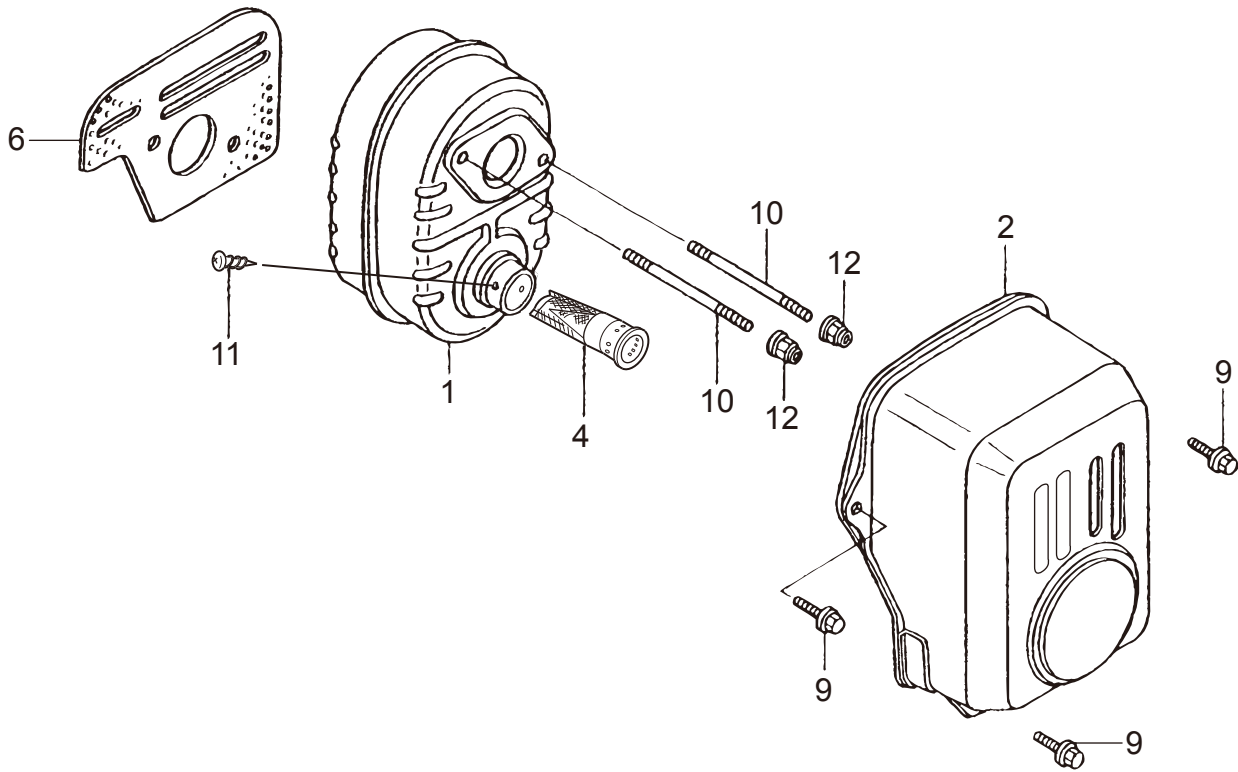

GX100RTKRBFB ENG. — MUFFLER ASSY.

<u>NO.</u>	<u>PART NO.</u>	<u>PART NAME</u>	<u>QTY.</u>	<u>REMARKS</u>
1	18310Z0DV20	MUFFLER COMPLETE	1	
2	18321Z0DV22	MUFFLER PROTECTOR	1	
4	18350ZL8000	ARRESTER COMPLETE, SPARK/RT-E	1	
6	18381Z0D000	GASKET, MUFFLER	1	
9	90014952000	BOLT, FLANGE 6X14	3	
10	90048Z0DV00	STUD BOLT 6X78	2	
11	90055ZE1000	TAPPING SCREW 4X6	1	
12	90343ZE6000	NUT, SELF-LOCK 6MM	2	

GX100RTKRBF ENG. — FLYWHEEL/IGN. COIL ASSY.

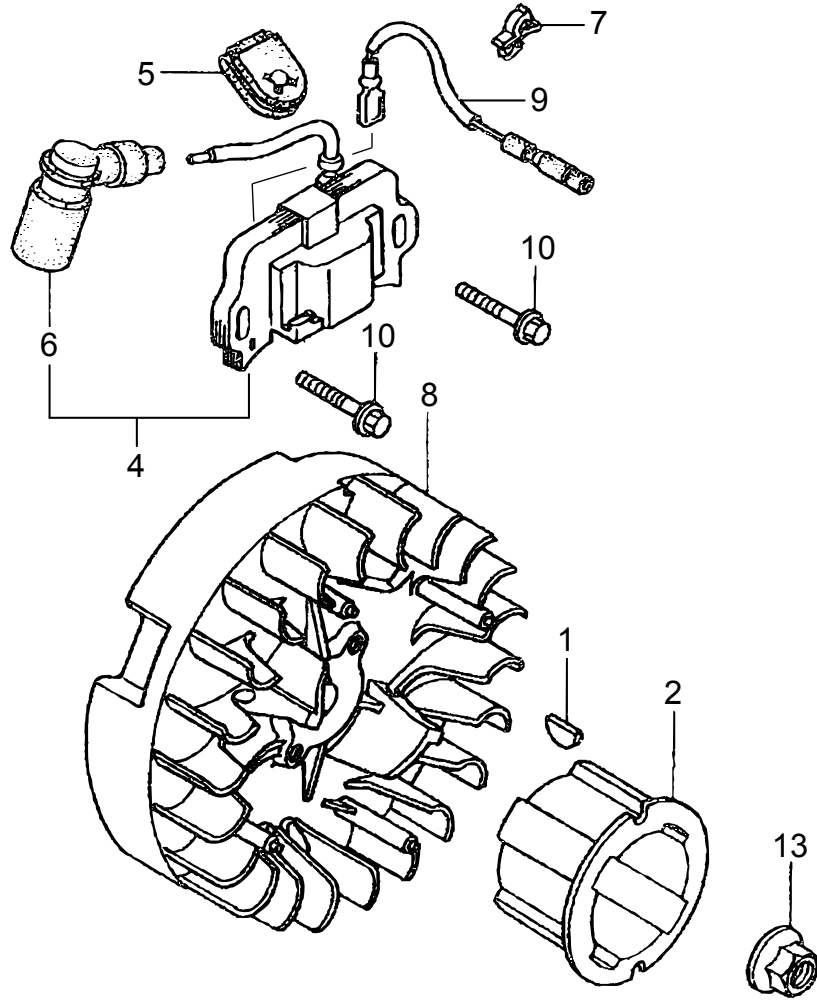

GX100RTKRBF ENG. — FLYWHEEL/IGN. COIL ASSY.

<u>NO.</u>	<u>PART NO.</u>	<u>PART NAME</u>	<u>QTY.</u>	<u>REMARKS</u>
1	13331ZM7000	WOODRUFF KEY 25X18	1	
2	28451Z0DV03	STARTER PULLEY	1	
4	30500Z0DV02	IGNITION COIL ASSY.....	1.....	INCLUDES ITEM W/#
5	30564ZA5000	GROMMET, CORD	1	
6#	30700Z0DV01	TERMINAL ASSY.	1	
7	30701883000	CLIP, HIGH TENSION CORD	1	
8	31110Z0D003	FLYWHEEL COMPLETE	1	
9	32195Z0D000	CORD, STOP SWITCH	1	
10	90022888010	FLANGE BOLT 6X20	2	
13	9405012000	FLANGE NUT M12	1	

GX100RTKRBF ENG. — CONTROL ASSY.

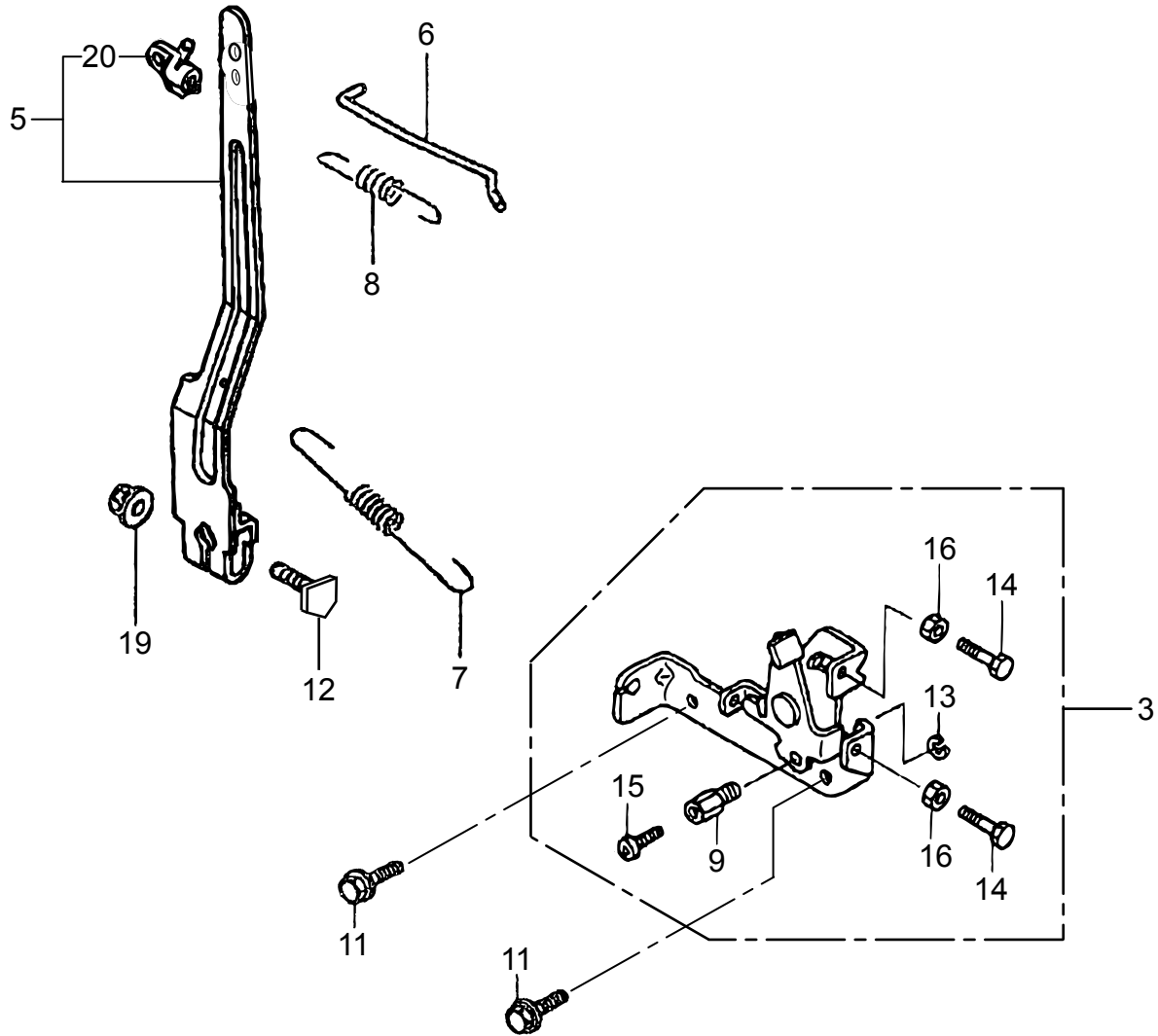

GX100RTKRB ENG. — CONTROL ASSY.

<u>NO.</u>	<u>PART NO.</u>	<u>PART NAME</u>	<u>QTY.</u>	<u>REMARKS</u>
3	16500Z4ES30	CONTROL ASSY.....	1.....	INCLUDES ITEMS W/\$
5	16550Z0DV01	GOVERNOR ARM	1.....	INCLUDES ITEM W/#
6	16555Z0DV00	GOVERNOR ROD	1	
7	16561Z0DV00	GOVERNOR SPRING	1	
8	16562Z4ES10	SPRING, THROTTLE	1	
9\$	16594883010	HOLDER, WIRE	1	
11	90014952000	BOLT, FLANGE 6X14	2	
12	90015Z5T000	BOLT, GOVERNOR ARM	1	
13\$	90605230000	CIR CLIP	1	
14\$	92301050220A	BOLT 5X20	2.....	REPLACES P/N 92301050200A
15\$	0043504060	SCREW 4X6	1.....	REPLACES P/N 93500040060H
16\$	940010500005	NUT M5.....	2.....	REPLACES P/N 9400105000
19	9405006000	FLANGE NUT 6MM	1	
20#	16263883W10	JOINT, ROD	1	

GX100RTKRBF ENG. — LABEL ASSY.

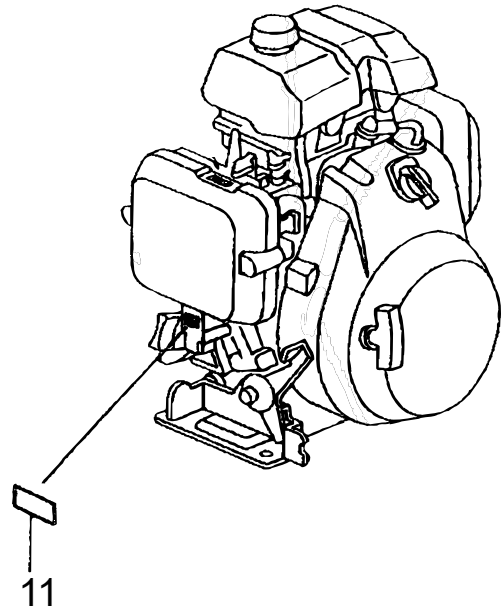
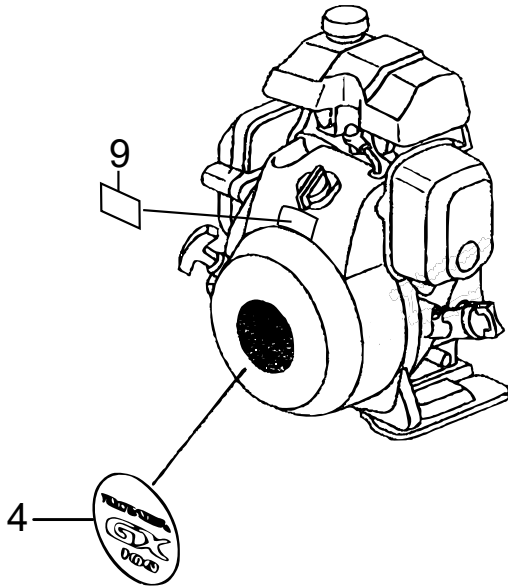

GX100RTKRBF ENG. — LABEL ASSY.

<u>NO.</u>	<u>PART NO.</u>	<u>PART NAME</u>	<u>QTY.</u>	<u>REMARKS</u>
4	87521ZDDP10	EMBLEM (GX100) (RAMMER)	1	
9	87539Z0J000	MARK, EX. CAUTION/PICTO	1	
11	87601Z4ES30	MARK, TYPE (KRBF)	1	

PARTS MANUAL

HERE'S HOW TO GET HELP

PLEASE HAVE THE MODEL AND SERIAL
NUMBER ON-HAND WHEN CALLING

UNITED STATES

Multiquip Inc.

(310) 537- 3700
6141 Katella Avenue Suite 200
Cypress, CA 90630
E-MAIL: mq@multiquip.com
WEBSITE: www.multiquip.com

CANADA

Multiquip

(450) 625-2244
4110 Industriel Boul.
Laval, Quebec, Canada H7L 6V3
E-MAIL: infocanada@multiquip.com

UNITED KINGDOM

Multiquip (UK) Limited Head Office

0161 339 2223
Unit 2, Northpoint Industrial Estate,
Globe Lane,
Dukinfield, Cheshire SK16 4UJ
E-MAIL: sales@multiquip.co.uk

© COPYRIGHT 2024, MULTIQUIP INC.

Multiquip Inc, the MQ logo are registered trademarks of Multiquip Inc. and may not be used, reproduced, or altered without written permission. All other trademarks are the property of their respective owners and used with permission.

This manual MUST accompany the equipment at all times. This manual is considered a permanent part of the equipment and should remain with the unit if resold.

The information and specifications included in this publication were in effect at the time of approval for printing. Illustrations, descriptions, references and technical data contained in this manual are for guidance only and may not be considered as binding. Multiquip Inc. reserves the right to discontinue or change specifications, design or the information published in this publication at any time without notice and without incurring any obligations.

