

# OPERATION MANUAL



*Mikasa* **SERIES**  
**MODEL MVC64VH/VHW**  
**ONE-WAY PLATE COMPACTOR**  
**(HONDA GX120U1SM12 GASOLINE ENGINE)**

Revision #4 (06/08/20)

To find the latest revision of this publication or  
associated parts manual, visit our website at:  
[www.multiquip.com](http://www.multiquip.com)



**THIS MANUAL MUST ACCOMPANY THE EQUIPMENT AT ALL TIMES.**

# PROPOSITION 65 WARNING

---





## **MVC64VH/VHW Plate Compactor**

Proposition 65 Warning .....	2
Safety Information .....	5–9
Specifications .....	10
Noise And Vibration Emissions.....	11
Dimensions.....	12
General Information.....	13
Components .....	14
Basic Engine.....	15
Inspection .....	16–17
Operation.....	18–19
Maintenance .....	20–22
Troubleshooting .....	23–24

### **NOTICE**

Specifications and part numbers are subject to change without notice.

# SAFETY INFORMATION

Do not operate or service the equipment before reading the entire manual. Safety precautions should be followed at all times when operating this equipment. Failure to read and understand the safety messages and operating instructions could result in injury to yourself and others.



## SAFETY MESSAGES

The four safety messages shown below will inform you about potential hazards that could injure you or others. The safety messages specifically address the level of exposure to the operator and are preceded by one of four words: **DANGER**, **WARNING**, **CAUTION** or **NOTICE**.

## SAFETY SYMBOLS

 **DANGER**

Indicates a hazardous situation which, if not avoided, **WILL** result in **DEATH** or **SERIOUS INJURY**.

 **WARNING**

Indicates a hazardous situation which, if not avoided, **COULD** result in **DEATH** or **SERIOUS INJURY**.







 **CAUTION**

Indicates a hazardous situation which, if not avoided, **COULD** result in **MINOR** or **MODERATE INJURY**.

**NOTICE**

Addresses practices not related to personal injury.

Potential hazards associated with the operation of this equipment will be referenced with hazard symbols which may appear throughout this manual in conjunction with safety messages.

Symbol	Safety Hazard
	Lethal exhaust gas hazards
	Explosive fuel hazards
	Burn hazards
	Respiratory hazards
	Accidental starting hazards
	Eye and hearing hazards
	Rotating parts hazards

# SAFETY INFORMATION

## GENERAL SAFETY

### ⚠ CAUTION

- **NEVER** operate this equipment without proper protective clothing, shatterproof glasses, respiratory protection, hearing protection, steel-toed boots and other protective devices required by the job or city and state regulations.



- **NEVER** operate this equipment when not feeling well due to fatigue, illness or when under medication. 
- **NEVER** operate this equipment under the influence of drugs or alcohol.



- **ALWAYS** check the equipment for loosened threads or bolts before starting.
- **DO NOT** use the equipment for any purpose other than its intended purposes or applications.
- **ALWAYS** clear the work area of any debris, tools, etc. that would constitute a hazard while the equipment is in operation.

### NOTICE

- This equipment should only be operated by trained and qualified personnel 18 years of age and older.
- Whenever necessary, replace nameplate, operation and safety decals when they become difficult read.
- Manufacturer does not assume responsibility for any accident due to equipment modifications. Unauthorized equipment modification will void all warranties.
- **NEVER** use accessories or attachments that are not recommended by Multiquip for this equipment. Damage to the equipment and/or injury to user may result.
- **ALWAYS** know the location of the nearest **fire extinguisher**. 
- **ALWAYS** know the location of the nearest **first aid kit**. 
- **ALWAYS** know the location of the nearest phone or **keep a phone on the job site**. Also, know the phone numbers of the nearest **ambulance, doctor and fire department**. This information will be invaluable in the case of an emergency.

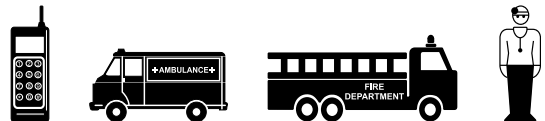

# SAFETY INFORMATION

## COMPACTOR SAFETY

### DANGER

- **NEVER** operate the equipment in an explosive atmosphere or near combustible materials. An explosion or fire could result causing severe bodily harm or even death.



### WARNING

- **NEVER** disconnect any **emergency or safety devices**. These devices are intended for operator safety. Disconnection of these devices can cause severe injury, bodily harm or even death. Disconnection of any of these devices will void all warranties.

### CAUTION

- **NEVER** lubricate components or attempt service on a running machine.

### NOTICE

- **ALWAYS** keep the machine in proper running condition.
- Fix damage to machine and replace any broken parts immediately.
- **ALWAYS** store equipment properly when it is not being used. Equipment should be stored in a clean, dry location out of the reach of children and unauthorized personnel.

## ENGINE SAFETY

### DANGER

- The engine fuel exhaust gases contain poisonous carbon monoxide. This gas is colorless and odorless, and can cause death if inhaled.
- The engine of this equipment requires an adequate free flow of cooling air. **NEVER** operate this equipment in any enclosed or narrow area where free flow of the air is restricted. If the air flow is restricted it will cause injury to people and property and serious damage to the equipment or engine.



### WARNING

- **DO NOT** place hands or fingers inside engine compartment when engine is running.
- **NEVER** operate the engine with heat shields or guards removed.
- Keep fingers, hands hair and clothing away from all moving parts to prevent injury.
- **DO NOT** remove the radiator cap while the engine is hot. High pressure boiling water will gush out of the radiator and severely scald any persons in the general area of the compactor.
- **DO NOT** remove the coolant drain plug while the engine is hot. Hot coolant will gush out of the coolant tank and severely scald any persons in the general area of the compactor.
- **DO NOT** remove the engine oil drain plug while the engine is hot. Hot oil will gush out of the oil tank and severely scald any persons in the general area of the compactor.



### CAUTION

- **NEVER** touch the hot exhaust manifold, muffler or cylinder. Allow these parts to cool before servicing equipment.



### NOTICE

- **NEVER** run engine without an air filter or with a dirty air filter. Severe engine damage may occur. Service air filter frequently to prevent engine malfunction.
- **NEVER** tamper with the factory settings of the engine or engine governor. Damage to the engine or equipment can result if operating in speed ranges above the maximum allowable.
- **NEVER** tip the engine to extreme angles during lifting as it may cause oil to gravitate into the cylinder head, making the engine start difficult.



# SAFETY INFORMATION

## FUEL SAFETY

### DANGER

- **DO NOT** add fuel to equipment if it is placed inside truck bed with plastic liner. Possibility exists of explosion or fire due to static electricity.

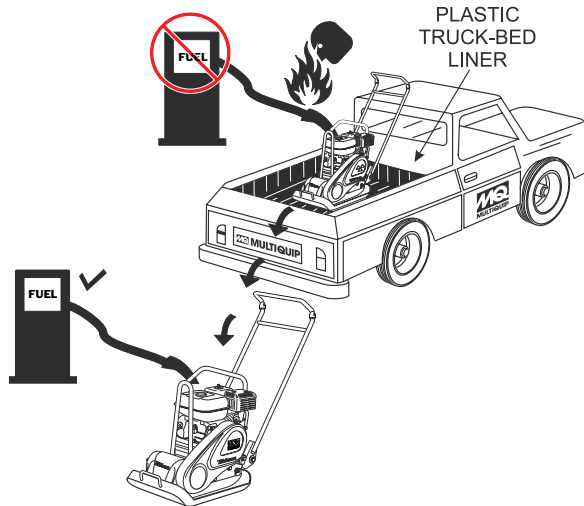

- **DO NOT** start the engine near spilled fuel or combustible fluids. Diesel fuel is extremely flammable and its vapors can cause an explosion if ignited.
- **ALWAYS** refuel in a well-ventilated area, away from sparks and open flames.
- **ALWAYS** use extreme caution when working with **flammable** liquids.
- **DO NOT** fill the fuel tank while the engine is running or hot.
- **DO NOT** overfill tank, since spilled fuel could ignite if it comes into contact with hot engine parts or sparks from the ignition system.
- Store fuel in appropriate containers, in well-ventilated areas and away from sparks and flames.
- **NEVER** use fuel as a cleaning agent.
- **DO NOT** smoke around or near the equipment. Fire or explosion could result from fuel vapors or if fuel is spilled on a hot engine.



## BATTERY SAFETY (ELECTRIC START ONLY)

### DANGER

- **DO NOT** drop the battery. There is a possibility that the battery will explode.
- **DO NOT** expose the battery to open flames, sparks, cigarettes, etc. The battery contains combustible gases and liquids. If these gases and liquids come into contact with a flame or spark, an explosion could occur.



### WARNING

- **ALWAYS** wear safety glasses when handling the battery to avoid eye irritation. The battery contains acids that can cause injury to the eyes and skin.
- Use well-insulated gloves when picking up the battery.
- **ALWAYS** keep the battery charged. If the battery is not charged, combustible gas will build up.
- **DO NOT** charge battery if frozen. Battery can explode. When frozen, warm the battery to at least 61°F (16°C).
- **ALWAYS** recharge the battery in a well-ventilated environment to avoid the risk of a dangerous concentration of combustible gases.
- If the battery liquid (dilute sulfuric acid) comes into contact with **clothing or skin**, rinse skin or clothing immediately with plenty of water.
- If the battery liquid (dilute sulfuric acid) comes into contact with **eyes**, rinse eyes immediately with plenty of water and contact the nearest doctor or hospital to seek medical attention.



### CAUTION

- **ALWAYS** disconnect the **NEGATIVE** battery terminal before performing service on the equipment.
- **ALWAYS** keep battery cables in good working condition. Repair or replace all worn cables.



## TRANSPORTING SAFETY

### CAUTION

- NEVER allow any person or animal to stand underneath the equipment while lifting.

### NOTICE

- Before lifting, make sure that the equipment parts (hook and vibration insulator) are not damaged and screws are not loose or missing.
- Always make sure crane or lifting device has been properly secured to the lifting bail (hook) of the equipment.
- **ALWAYS** shutdown engine before transporting.
- **NEVER** lift the equipment while the engine is running.
- Tighten fuel tank cap securely and close fuel cock to prevent fuel from spilling.
- Use adequate lifting cable (wire or rope) of sufficient strength.
- Use one point suspension hook and lift straight upwards.
- **DO NOT** lift machine to unnecessary heights.
- **ALWAYS** tie down equipment during transport by securing the equipment with rope.

## ENVIRONMENTAL SAFETY

### NOTICE

- Dispose of hazardous waste properly. Examples of potentially hazardous waste are used motor oil, fuel and fuel filters. 
- **DO NOT** use food or plastic containers to dispose of hazardous waste.
- **DO NOT** pour waste, oil or fuel directly onto the ground, down a drain or into any water source.

# SPECIFICATIONS

**Table 1. Compactor Specifications**

Model	MVC64VH/VHW
Centrifugal Force	2,275 lbs. (1,032 kg)
Vibration Frequency	5,600 vpm (93 Hz)
Maximum Forward Speed	82 ft/min (25 m/min)
Plate Size (L x W)	22.4 x 13.8 in (570 x 350 mm)
Overall Dimensions (L x W x H)	36.6 x 13.8 x 39.4 in (930 x 350 x 1000 mm)
Operating Weight (with water tank)	176 lbs. (80 kg)
Operating Weight (without water tank)	161 lbs. (73 kg)
Maximum Area of Compaction	5,658 sq. ft/hr (526 sq. m/hr)

**Table 2. Engine Specifications**

Make	Honda
Model	GX120U1SM12
Type	Air-cooled 4 stroke, Single Cylinder, OHV Horizontal Shaft Gasoline Engine
Bore X Stroke	2.4 in. x 1.7 in. (60 mm x 42 mm)
Displacement	119 cc (7.2 cu-in)
Max Output	4.0 H.P./3600 R.P.M.
Fuel Tank Capacity	0.66 US gal. (2.5 liters)
Fuel	Unleaded Automobile Gasoline
Lube Oil Capacity	.60 liters (0.63 qts)
Speed Control Method	Centrifugal Fly-weight Type
Starting Method	Recoil Start
Dimension (L x W x H)	11.7 x 13.4 x 12.5 in. (297 x 341 x 318 mm)
Dry Net Weight	28.7 lbs (13 Kg.)

# NOISE AND VIBRATION EMISSIONS

**Table 3. Noise and Vibration Emissions**

Measured Sound Power Level in dB(A)	101
Guaranteed Sound Power Level in dB(A)	105
Guaranteed Sound Pressure Level at Operator Station in dB(A)	89
Hand-Arm Vibration in m/s <sup>2</sup>	3.3

## NOTES:

1. *Products are tested for sound pressure level in accordance with European Directives 2000/14/EC and 2005/88/EC, relating to Noise Emission in the Environment by equipment for use outdoors.*
2. *Products are tested for hand/arm vibration (HAV) level in accordance with European Directives 2002/44/EC and EN500-4 and ISO 5349-1:2001, ISO 5349-2:2001.*

# DIMENSIONS

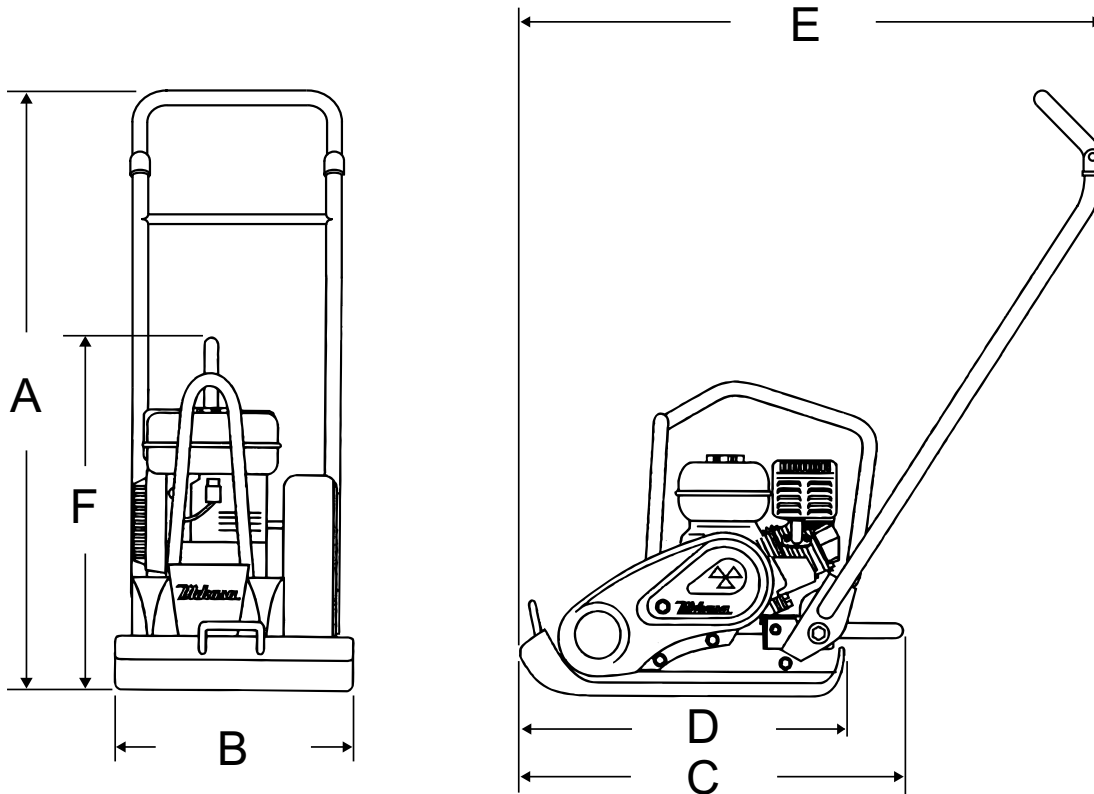

**Table 4. Dimensions**

Reference Letter	Description	DIMENSION in. (mm)
A	Height (Handle Upright)	39 in. (1000 mm)
B	Width	13 in. (330 mm)
C	Length (Handle Upright)	24 in. (609 mm)
D	Plate Length	22 in. (560 mm)
E	Length (Handle Lowered)	37 in. (940 mm)
F	Height (Compactor Only)	23 in. (590 mm)
	Shipping Dimensions	30 x 15 x 30 in. (762 x 381 x 762 mm)

## **GENERAL INFORMATION**

---

### **DEFINITION OF PLATE COMPACTOR**

The Mikasa MVC-64VH/VHW is a walk behind, plate compactor designed for the compaction of sand, mixed soils and asphalt. This plate compactor is a powerful compacting tool capable of applying a tremendous force in consecutive high frequency vibrations to a soil surface. Its applications include compacting for road, embankments and reservoirs as well as backfilling for gas pipelines, water pipelines and cable installation work.

The MVC-64VH/VHW is small and lightweight. It can be easily handled by one person in confined areas. It has an accessible front-mounted vibrator assembly. The sealed belt cover keeps dirt and rocks away from the belt.

### **VIBRATORY PLATE**

The vibratory plate of the compactor produces low amplitude high frequency vibrations, designed to compact granular soils and asphalt.

The resulting vibrations cause forward motion. The engine and handle are vibration isolated from the vibrating plate.

### **FREQUENCY/SPEED**

The compactor's vibrating plate has a frequency of 5,600 vpm (vibrations per minute). The travel speed of the compactor is approximately 82 ft./minute (25 meters/minute).

### **ENGINE**

The Mikasa MVC-64VH/VHW Plate Compactor is equipped with a Honda GX120U1SM12 gasoline engine.

### **CONTROLS**

Before starting the MVC-64VH/VHW Plate Compactor identify and understand the function of the controls and components.

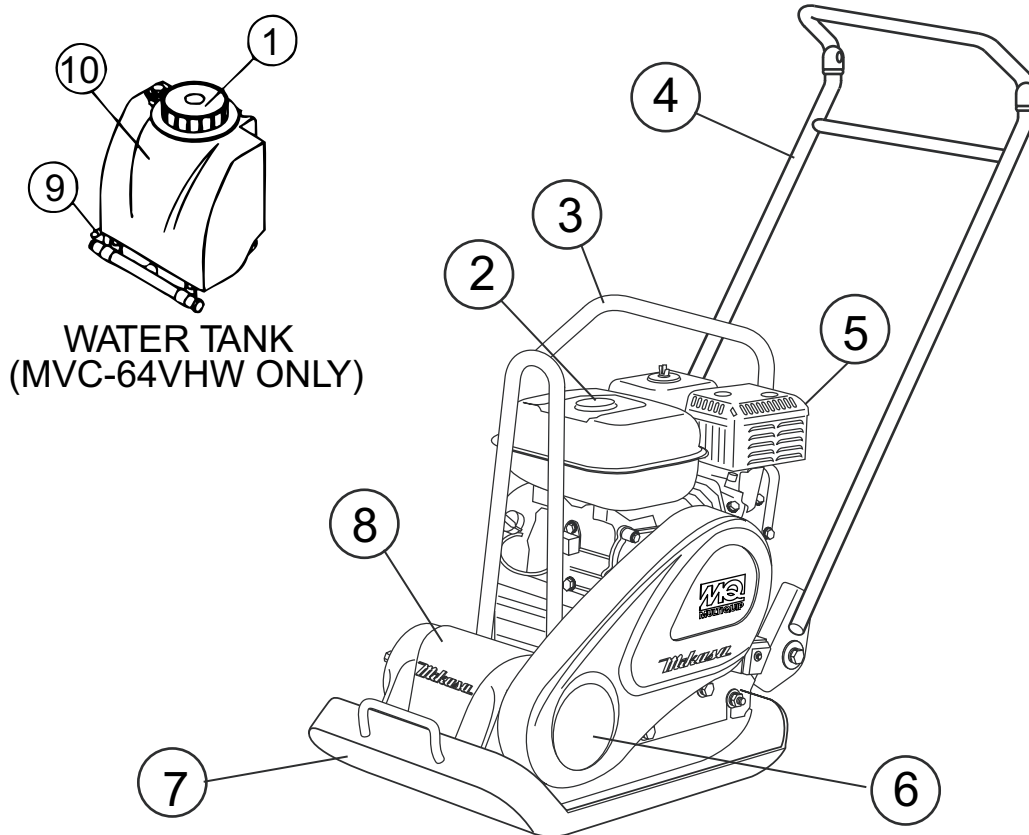

**Figure 1. Plate Compactor Components**

Figure 1 shows the location of the basic controls and components of the MVC64VH/VHW Plate Compactor. The function of each control is described below:

1. **Water Tank Cap (VHW Only)** — Remove this cap to add water to the water tank.
2. **Fuel Tank Cap** — Remove this cap to add fuel.
3. **Lifting Bale** — When lifting of the compactor is required either by forklift, crane, etc., tie rope or chain around this lifting point.
4. **Handle Bar** — When operating the compactor use this handle bar to maneuver the compactor.
5. **Gasoline Engine** — This plate compactor uses a GX120U1SM12 HONDA engine. Refer to the HONDA owner's manual for engine information and related topics.
6. **Belt Cover** — Remove this cover to gain access to the
7. **Vibrating Plate** — A flat, open plate made of durable cast iron construction used in the compacting of soil.
8. **Vibration Case** — Encloses the eccentric, gears and counter weights.
9. **Water Shut-Off Valve (VHW only)** — Turn this valve downward to let water flow from the water tank to the water tube.
10. **Water Tank (VHW only)** — Holds 10.6 quarts (10 liters) of water (removable, no tools required).

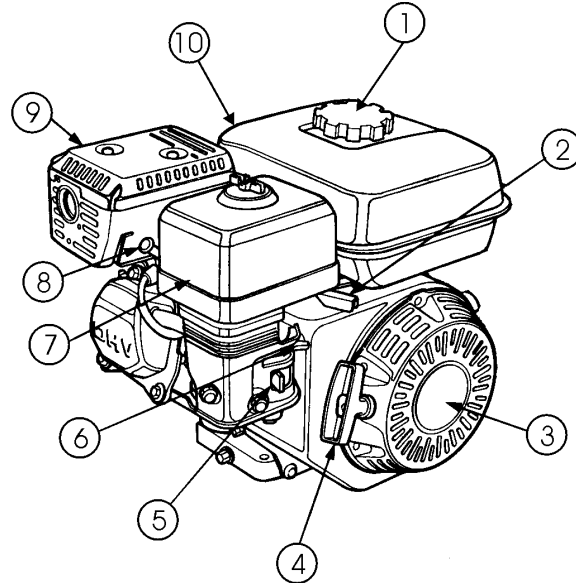

**Figure 2. Engine Components**

The engine (Figure 2) must be checked for proper lubrication and filled with fuel prior to operation. Refer to the manufacturer's engine manual for instructions and details of operation and servicing.

1. **Fuel Filler Cap** — Remove this cap to add unleaded gasoline to the fuel tank. Make sure cap is tightened securely. **DO NOT** over fill.

**WARNING**



Adding fuel to the tank should be accomplished only when the engine is stopped and has had an opportunity to cool down. In the event of a fuel spill, **DO NOT** attempt to start the engine until the fuel residue has been completely wiped up, and the area surrounding the engine is dry.

2. **Throttle Lever** — Used to adjust engine RPM speed (lever advanced forward - **SLOW**, lever back toward operator - **FAST**).
3. **Engine ON/OFF Switch** — **ON** position permits engine starting, **OFF** position stops engine operations.
4. **Recoil Starter (pull rope)** — Manual-starting method. Pull the starter grip until resistance is felt, then pull briskly and smoothly.
5. **Fuel Valve Lever** — **OPEN** to let fuel flow, **CLOSE** to stop the flow of fuel.

6. **Choke Lever** — Used in the starting of a cold engine, or in cold weather conditions. The choke enriches the fuel mixture.
7. **Air Cleaner** — Prevents dirt and other debris from entering the fuel system. Remove wing-nut on top of air filter cover to gain access to filter element.

**NOTICE**

Operating the engine without an air filter, with a damaged air filter, or a filter in need of replacement will allow dirt to enter the engine, causing rapid engine wear.

8. **Spark Plug** — Provides spark to the ignition system. Set spark plug gap to 0.6 - 0.7 mm (0.028 - 0.031 inch). Clean spark plug once a week.
9. **Muffler** — Used to reduce noise and emissions.

**WARNING**



Engine components can generate extreme heat. To prevent burns, **DO NOT** touch these areas while the engine is running or immediately after operating. **NEVER** operate the engine with the muffler removed.

10. **Fuel Tank** — Holds unleaded gasoline. For additional information refer to engine owner's manual.

## BEFORE STARTING

1. Read safety instructions at the beginning of manual.
2. Clean the compactor, removing dirt and dust, particularly the engine cooling air inlet, carburetor and air cleaner.
3. Check the air filter for dirt and dust. If air filter is dirty, replace air filter with a new one as required.
4. Check carburetor for external dirt and dust. Clean with dry compressed air.
5. Check fastening nuts and bolts for tightness. Loosened screws or bolts due to vibration, could lead to unexpected accident.

## ENGINE OIL CHECK

1. To check the engine oil level, place the pump on secure level ground with the engine stopped.
2. Remove the filler dipstick from the engine oil filler hole (Figure 3) and wipe clean.

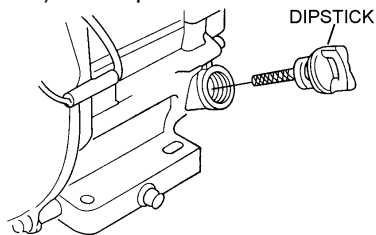

**Figure 3. Engine Oil Dipstick Removal**

3. Insert and remove the dipstick without screwing it into the filler neck. Check the oil level shown on the dipstick.
4. If the oil level is low (Figure 4), fill to the edge of the oil filler hole with the recommended oil type (Table 5).

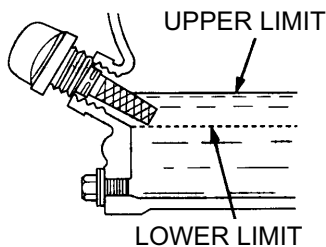

**Figure 4. Engine Oil Dipstick (Oil Level)**

### NOTICE

The Oil Alert System will automatically stop the engine before the engine falls below safe limits. Always be sure to check the engine oil level prior to starting the engine.

**Table 5. Oil Type**

Season	Temperature	Oil Type
Summer	25°C or Higher	SAE 10W-30
Spring/Fall	25°C ~ 10°C	SAE 10W-30/20
Winter	0°C or Lower	SAE 10W-10

### WARNING



Adding fuel to the tank should be accomplished only when the engine is stopped and has had an opportunity to cool down. In the event of a fuel spill, **DO NOT** attempt to start the engine until the fuel residue has been completely wiped up, and the area surrounding the engine is dry.

## FUEL CHECK

1. Visually inspect (Figure 5) to see if fuel level is low. If fuel is low, replenish with unleaded fuel.

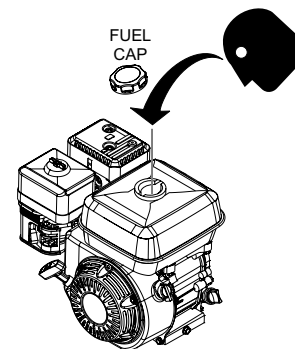
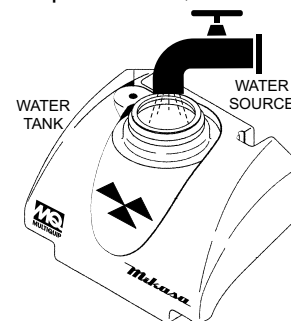

**Figure 5. Fuel Check**

2. When refueling, be sure to use a strainer for filtration. **DO NOT** top-off fuel. Wipe up any spilled fuel immediately.

## Water Tank (Option)

If your unit is equipped with a water tank (Figure 6) and your application requires water, fill water tank.



**Figure 6. Water Tank Filling**



## V-BELT CHECK

### **CAUTION**

**NEVER** attempt to check the V-belt with the engine running. Severe injury can occur if your hand (Figure 7) gets caught between the V-belt and the clutch. Always use safety gloves.

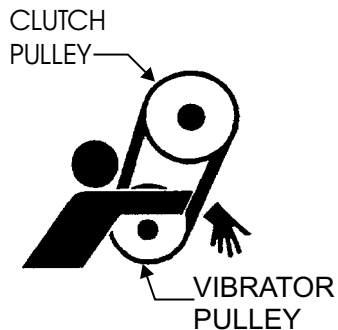

**Figure 7. V-Belt Hazard**

1. To check the V-belt tension, remove the three bolts that secure the belt cover to the frame as shown in Figure 8.

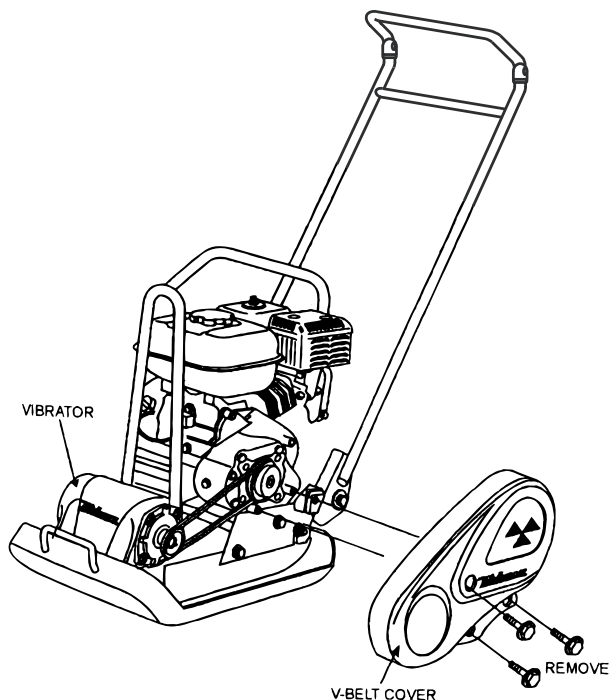

**Figure 8. V-Belt Cover Removal**

2. The V-belt tension is proper if the V-belt bends 10 to 15 mm (Figure 9) when depressed with finger midway between the clutch and vibration pulley shafts.

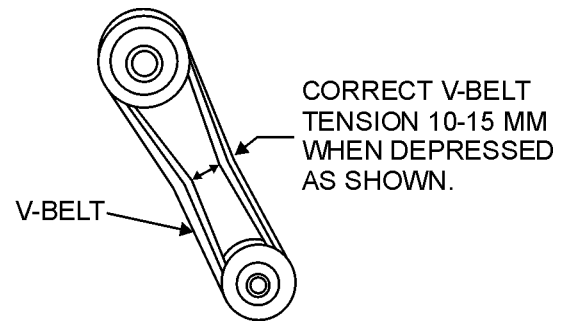
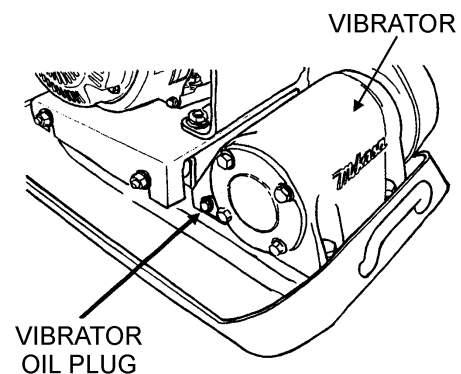

**Figure 9. V-Belt Tension**

3. A loose V-belt will decrease the power transmission output causing reduced compaction and premature wear of the belt.
4. If the V-belt becomes worn or loose, replace it.

## VIBRATOR OIL CHECK

1. Place the plate compactor horizontally on a flat surface. Make sure the compactor is level when checking the oil in the vibrator assembly.
2. Check vibrator oil level by removing the oil plug (vibrator oil gauge) as shown in Figure 10. The oil level should be up to the oil plug. **IMPORTANT**, if oil is required, replace using only SAE10W-30 motor oil.



**Figure 10. Vibrator Oil Plug**

## INITIAL START-UP

1. Place the fuel valve lever (Figure 11) in the **ON** position.

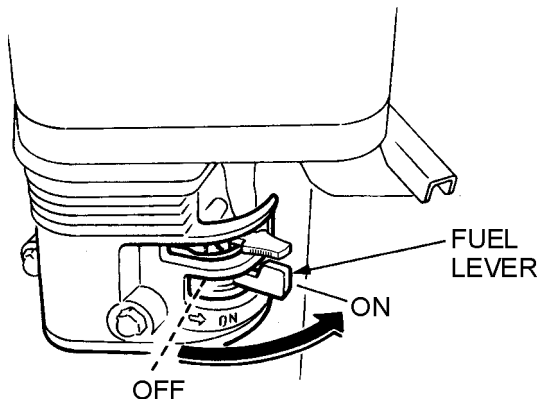

Figure 11. Fuel Valve Lever

2. Place the engine ON/OFF switch (Figure 12) in the **ON** position.

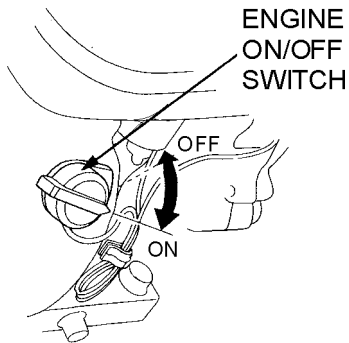

Figure 12. Engine ON/OFF Switch

3. Place the choke lever (Figure 13) in the **OPEN** position.

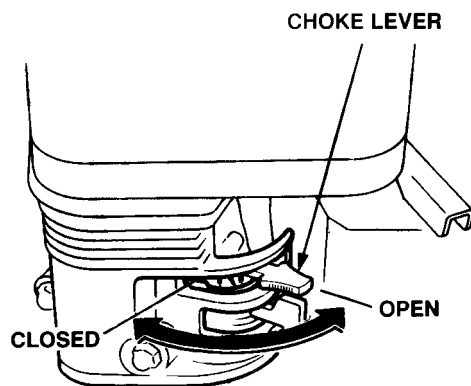

Figure 13. Choke Lever

### NOTICE

The **CLOSED** position of the choke lever enriches the fuel mixture for starting a **COLD** engine. The **OPEN** position provides the correct fuel mixture for normal operation after starting, and for restarting a warm engine.

4. Place the throttle lever (Figure 14) halfway between **FAST** and **SLOW**.

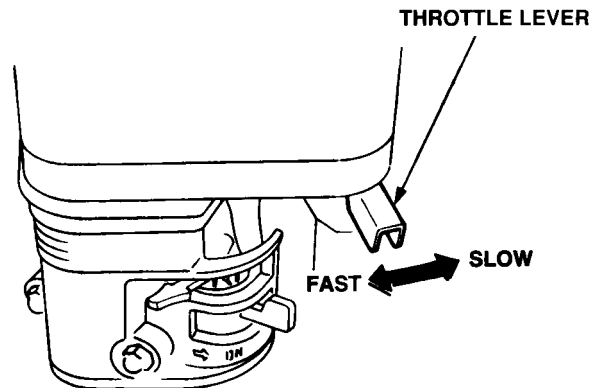

Figure 14. Throttle Lever

5. Grasp the starter grip (Figure 15) and slowly pull it out. The resistance becomes the hardest at a certain position, corresponding the compression point. Rewind the rope a little from that point and pull out sharply.

### NOTICE

**DO NOT** pull the starter rope all the way to the end.

**DO NOT** release the starter rope after pulling. Allow it to rewind as soon as possible.

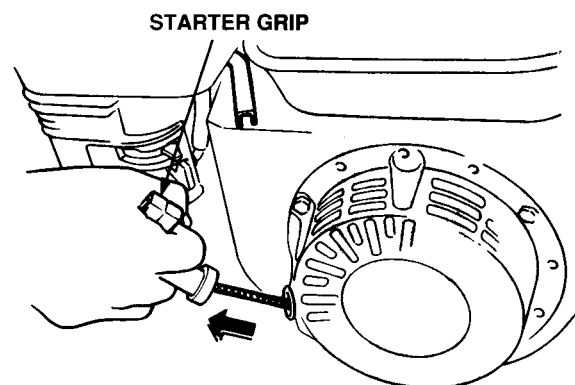

Figure 15. Starter Grip

6. If the choke lever was moved to the **CLOSED** position, slowly return the choke lever to the **OPEN** position.
  7. If the engine has not started, repeat steps 1 through 5.
  8. Before the compactor is put into operation, run the engine for 3-5 minutes.
  9. Check for abnormal engine noises or fuel leaks.
5. Compactor traveling speed may drop on soils which contain clay. However, there may be cases where traveling speed drops because the compaction plate does not leave the ground surface easily due to the composition of the soil. To rectify this problem, do the following:
    - a. Check the bottom plate to see if clay or equivalent material has been lodged in the plate mechanism. If so, wash with water and remove.
    - b. Remember the compactor does not work as efficiently on clay or soils that have a high moisture content level. If the soil has a high moisture level, dry soil to appropriate moisture content level or carry out compaction twice.

## OPERATION

### CAUTION

Make sure to follow all safety rules referenced in the safety information section of this manual before operating compactor. Keep work area clear of debris and other objects that could cause damage to the compactor or bodily injury.

1. Once the engine has started, move the engine throttle lever quickly to the fast position.
2. With the throttle lever in the fast position, the engine speed should be around 2,300 RPM therefore engaging the centrifugal clutch.

### NOTICE

**ALWAYS** move the throttle lever quickly without hesitation, because increasing the engine speed slowly causes the clutch to slip.

3. Firmly grasp the compactor's handle bar with both hands. The compactor will begin moving forward.
4. Slowly walk behind the compactor and be on the lookout for any large objects or foreign matter that might cause damage to the compactor or bodily injury.

## STOPPING THE ENGINE

### CAUTION

**NEVER** stop the engine suddenly while working at high speeds.

### Normal Shutdown

1. Place the throttle lever (Figure 14) in slow position, and listen for the engine speed to decrease.
2. Place the Engine **ON/OFF** switch (Figure 10) in the **OFF** position.
3. Place the fuel valve lever (Figure 9) in the **OFF** position.

### Emergency Shutdown

Move the throttle lever quickly to the **SLOW** position, and place the Engine **ON/OFF** switch in the **OFF** position.

## NOTICE

Inspection and other services should always be carried out on hard and level ground with the engine shutdown.

## NOTICE

The inspection intervals listed in the maintenance tables are for operation under normal conditions. Adjust your inspection intervals based on the number hours plate compactor is in use, and particular working conditions.

**Table 6. Engine Check**

Item	Hours of Operation
Leakage of Oil or Fuel	Every 8 hours (everyday)
Tightness of Fastening Threads	Every 8 hours (everyday)
Damage of any part	Every 8 hours (everyday)
Engine Oil Check and Replenishment	Every 8 hours (everyday) Replenish to specified max. level
Engine Oil Replenishment	After first 20 hours then every 100 hours
Air Cleaner Cleaning	Every 50 hours

**Table 7. Machine Inspection**

Item	Hours of Operation
Starting Check	Every 8 hours (everyday)
Loose or lost screws	Every 8 hours (everyday)
Damage of any part	Every 8 hours (everyday)
Function of controlling system part	Every 8 hours (everyday)
Vibrator Oil Check	Every 100 hours
Vibrator Oil Replacement	Every 300 hours
V-belt (clutch) Check	Every 200 hours

## DAILY SERVICE

1. Check for leakage of fuel or oil.
2. Check engine oil.

## NOTICE

Fuel piping and connections should be replaced every 2 years.

3. Check for loose screws including tightness. See Table 8 for retightening.

**Table 8. Tightening Torque (kg/cm) Diameter**

Material	6 mm	8 mm	10mm	12mm	14mm	16mm	18mm	20mm
4T	70	150	300	500	750	1,100	1,400	2,000
6-8T	100	250	500	800	1,300	2,000	2,700	3,800
11T	150	400	800	1,200	2,000	2,900	4,200	5,600
*	100 (6mm) 300 ~ 350 (8mm) 650 ~ 700 (10mm)							
* In case counterpart is of aluminum								
Threads in use with this machine are all right handed.								
Material and quality of material is marked on each bolt and screw.								

## ENGINE OIL

1. Replace the engine oil in first 20 hours of operation and every 100 hours afterwards.
2. Drain the engine oil when the oil is warm after operation. Remove the oil filler cap then unscrew the engine oil drain plug located at the base of the engine. Drain the old oil into a pan (Figure 16).

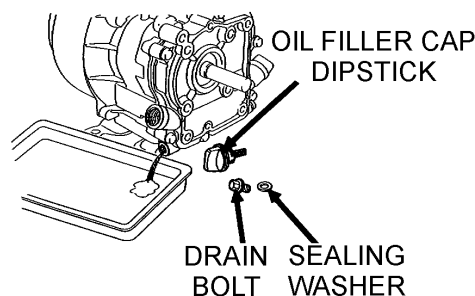

**Figure 16. Engine Oil (Draining)**

3. Replace engine oil with recommended type oil as listed in Table 5. For engine oil capacity, see Table 2 (engine specifications). **DO NOT** overfill.
4. Reinstall drain bolt with sealing washer and tighten securely.

## AIR FILTER

1. The air filter element should be cleaned because a clogged air cleaner can cause poor engine starting, lack of power and shorten engine life substantially.
2. To clean or replace air filter loosen the wing nut on the air filter housing (Figure 17), remove the cover and take out air filter cartridge. If only cleaning of the air filter is desired blow through the air filter cartridge from the inside, moving a jet of dry compressed air up and down until all dust is removed.

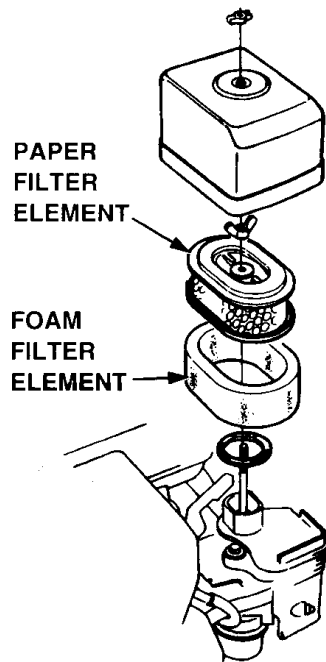

Figure 17. Air Filter

## SPARK PLUG

1. Remove and clean the spark plug (Figure 16).

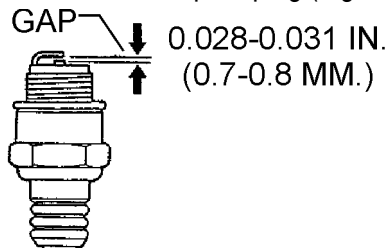

Figure 18. Spark Plug Gap

2. Adjust the spark gap to 0.028~0.031 inch (0.6~0.7 mm). This unit has electronic ignition which requires no adjustments.

## CHANGING VIBRATOR OIL

1. When changing the vibrator oil, remove the drain plug.
2. Tip the compactor to drain the oil. Note that the oil will drain more easily while it is hot.
3. Remember to use only 10W-30 motor oil when replacing vibrator oil.

## CHECKING/REPLACING THE V-BELT AND CLUTCH

After 200 hours of operation, remove the upper belt cover to check the V-belt tension. Tension is proper if the belt bends about 10 mm when depressed strongly with finger between shafts. Loose or worn V-belts reduces power transmission efficiency, causing weak compaction and reduces the life of the belt itself.

## CHECKING V-BELT

Visually examine the V-belt (Figure 19) and determine if it is full of tiny cracks, frayed, has pieces of rubber missing, is peeling or otherwise damaged.

Also, examine the belt and determine if it is **oil soaked** or **"glazed"** (hard shiny appearance on the sides of the belt). Either of these two conditions can cause the belt to run hot, which can weaken it and increase the danger of it breaking.

If the V-belt exhibits any of the above wear conditions replace the V-belt immediately.

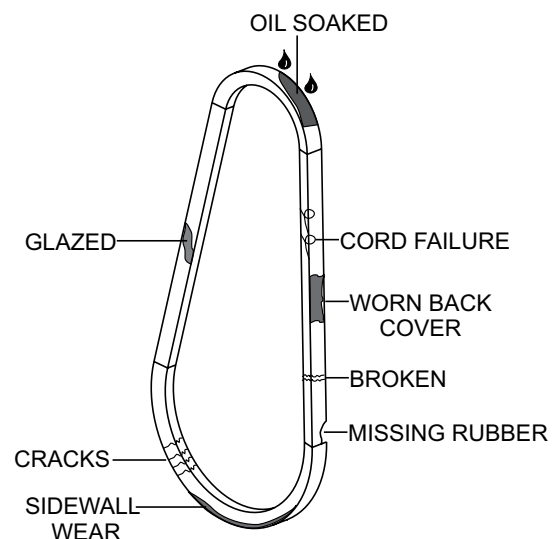

Figure 19. V-Belt Inspection

## REPLACING THE V-BELT

Remove the upper and lower belt covers. Engage an offset wrench (13 mm) or the like to vibrator pulley (lower) fastening bolt. Engage waste cloth or the like at midway of V-belt on the left side and while pulling it back strongly, rotate the offset wrench clockwise so that the V-belt will come off.

## REINSTALLING THE V-BELT

Engage V-belt to lower vibrator pulley and push the V-belt to left side of upper clutch and, in the same manner as in removal, rotate offset wrench clockwise so that the V-belt goes back on.

## CHECKING CLUTCH

Check the clutch simultaneously with V-belt checking. With belt removed, visually check outer drum of the clutch for seizure and "V" groove for wear or damage. Clean the "V" groove as necessary. Wear of lining or shoe should be checked regularly. If the shoe is worn, power transmission becomes deficient and slipping will result.

### **WARNING**

**NEVER** attempt to check the V-belt with the engine running. Severe injury can occur if your hand (Figure 7) gets caught between the V-belt and the clutch. Always use safety gloves.

## PLATE COMPACTOR STORAGE

For storage of the plate compactor for over 30 days, the following is required:

- Drain the fuel tank completely or add STA-BIL to the fuel.
- Run the engine until the fuel is completely consumed.
- Completely drain the oil from the engine crankcase and follow procedures described in the HONDA engine Owner's Manual for engine storage.
- Completely drain the compactor's hydraulic oil from the vibrating case.
- Clean entire plate compactor, especially the bottom plate removing all dirt and foreign matter.
- Cover plate compactor and engine with plastic covering or equivalent and store in a clean, dry place.

# TROUBLESHOOTING

Troubleshooting (Engine)		
Symptom	Possible Problem	Solution
Difficult to start, fuel is available, but no spark at spark plug.	Spark plug bridging?	Check gap, insulation or replace spark plug.
	Carbon deposit on spark plug?	Clean or replace spark plug.
	Short circuit due to deficient spark plug insulation?	Check spark plug insulation, replace if worn.
	Improper spark plug gap?	Set to proper gap.
	Spark plug is red?	Check transistor ignition unit.
	Spark plug is bluish white?	If insufficient compression, repair or replace engine. If injected air leaking, correct leak. If carburetor jets clogged, clean carburetor.
	No spark present at tip of spark plug?	Check if transistor ignition unit is broken, and replace defective unit. Check if voltage cord cracked or broken and replace. Check if spark plug is fouled and replace.
	No oil?	Add oil as required.
	Oil pressure alarm lamp blinks upon starting? (if applicable)	Check automatic shutdown circuit, oil sensor. (if applicable)
Difficult to start, fuel is available, and spark is present at the spark plug.	ON/OFF switch is shorted?	Check switch wiring, replace switch.
	Ignition coil defective?	Replace ignition coil.
	Improper spark gap, points dirty?	Set correct spark gap and clean points.
	Condenser insulation worn or short circuiting?	Replace condenser.
	Spark plug wire broken or short circuiting?	Replace defective spark plug wiring.
Difficult to start, fuel is available, spark is present and compression is normal.	Wrong fuel type?	Flush fuel system, replace with correct type of fuel.
	Water or dust in fuel system?	Flush fuel system.
	Air cleaner dirty?	Clean or replace air cleaner.
	Choke open?	Close choke.
Difficult to start, fuel is available, spark is present and compression is low.	Suction/exhaust valve stuck or protruded?	Reseat valves.
	Piston ring and/or cylinder worn?	Replace piston rings and/or piston.
	Cylinder head and/or spark plug not tightened properly?	Torque cylinder head bolts and spark plug.
	Head gasket and/or spark plug gasket damaged?	Replace head and spark plug gaskets.
No fuel present at carburetor.	No fuel in fuel tank?	Fill with correct type of fuel.
	Fuel cock does not open properly?	Apply lubricant to loosen fuel cock lever, replace if necessary.
	Fuel filter/lines clogged?	Replace fuel filter.
	Fuel tank cap breather hole clogged?	Clean or replace fuel tank cap.
	Air in fuel line?	Bleed fuel line.

# TROUBLESHOOTING

<b>Troubleshooting (Plate Compactor)</b>		
<b>Symptom</b>	<b>Possible Problem</b>	<b>Solution</b>
Travel speed too low, and vibration is weak.	Engine speed too low?	Set engine speed to correct RPM.
	Clutch slips?	Check or replace clutch.
	V-belt slips?	Adjust or replace V-belt.
	Excessive oil in vibrator?	Drain excess oil and fill to proper level.
	Malfunction in vibrator housing?	Check eccentric, gears and counter weights.
	Bearing Failure?	Replace bearing.
	Insufficient engine output?	Check engine, compression etc.





# OPERATION MANUAL

## HERE'S HOW TO GET HELP

PLEASE HAVE THE MODEL AND SERIAL  
NUMBER ON-HAND WHEN CALLING

### UNITED STATES

#### *Multiquip Inc.*

(310) 537- 3700  
6141 Katella Avenue Suite 200  
Cypress, CA 90630  
E-MAIL: [mq@multiquip.com](mailto:mq@multiquip.com)  
WEBSITE: [www.multiquip.com](http://www.multiquip.com)

### CANADA

#### *Multiquip*

(450) 625-2244  
4110 Industriel Boul.  
Laval, Quebec, Canada H7L 6V3  
E-MAIL: [infocanada@multiquip.com](mailto:infocanada@multiquip.com)

### UNITED KINGDOM

#### *Multiquip (UK) Limited Head Office*

0161 339 2223  
Unit 2, Northpoint Industrial Estate,  
Globe Lane,  
Dukinfield, Cheshire SK16 4UJ  
E-MAIL: [sales@multiquip.co.uk](mailto:sales@multiquip.co.uk)

© COPYRIGHT 2020, MULTIQUIP INC.

Multiquip Inc, the MQ logo are registered trademarks of Multiquip Inc. and may not be used, reproduced, or altered without written permission. All other trademarks are the property of their respective owners and used with permission.

This manual MUST accompany the equipment at all times. This manual is considered a permanent part of the equipment and should remain with the unit if resold.

The information and specifications included in this publication were in effect at the time of approval for printing. Illustrations, descriptions, references and technical data contained in this manual are for guidance only and may not be considered as binding. Multiquip Inc. reserves the right to discontinue or change specifications, design or the information published in this publication at any time without notice and without incurring any obligations.

Your Local Dealer is:

