

PARTS MANUAL



Mikasa

MODEL MVCe64V
ONE-WAY PLATE COMPACTOR
(HONDA GXE2.0H 2.4 HP ELECTRIC MOTOR)

Revision #2 (06/02/26)

To find the latest revision of this publication or associated operation manual, visit our website at: www.multiquip.com



THIS MANUAL MUST ACCOMPANY THE EQUIPMENT AT ALL TIMES.

**MVCe64V
Plate Compactor**

Explanation of Code in Remarks Column..... 4
Suggested Spare Parts 5

Component Drawings

Nameplate and Decals Assembly..... 6-7
Body Assembly8-11
Electric Motor Assembly 12-13
Battery Tray Assembly 14-15
Battery Charger Assembly 16-17
Water Tank Assembly (Option) 18-19
Transport Wheel Assembly (Option)..... 20-21
Vibrator Assembly..... 22-23

NOTICE
Specifications and part numbers are subject to change without notice.

EXPLANATION OF CODE IN REMARKS COLUMN

The following section explains the different symbols and remarks used in the Parts section of this manual. Use the help numbers found on the back page of the manual if there are any questions.

NOTICE

The contents and part numbers listed in the parts section are subject to change without notice. Multiquip does not guarantee the availability of the parts listed.

SAMPLE PARTS LIST

NO.	PART NO.	PART NAME	QTY.	REMARKS
1	12345	BOLT	1	INCLUDES ITEMS W/%
2%		WASHER, 1/4 IN.		NOT SOLD SEPARATELY
2%	12347	WASHER, 3/8 IN. ...	1	MQ-45T ONLY
3	12348	HOSE	A/R	MAKE LOCALLY
4	12349	BEARING	1	S/N 2345B AND ABOVE

NO. Column

Unique Symbols — All items with same unique symbol (@, #, +, %, or >) in the number column belong to the same assembly or kit, which is indicated by a note in the “Remarks” column.

Duplicate Item Numbers — Duplicate numbers indicate multiple part numbers, which are in effect for the same general item, such as different size saw blade guards in use or a part that has been updated on newer versions of the same machine.

NOTICE

When ordering a part that has more than one item number listed, check the remarks column for help in determining the proper part to order.

PART NO. Column

Numbers Used — Part numbers can be indicated by a number, a blank entry, or TBD.

TBD (To Be Determined) is generally used to show a part that has not been assigned a formal part number at the time of publication.

A blank entry generally indicates that the item is not sold separately or is not sold by Multiquip. Other entries will be clarified in the “Remarks” Column.

QTY. Column

Numbers Used — Item quantity can be indicated by a number, a blank entry, or A/R.

A/R (As Required) is generally used for hoses or other parts that are sold in bulk and cut to length.

A blank entry generally indicates that the item is not sold separately. Other entries will be clarified in the “Remarks” Column.

REMARKS Column

Some of the most common notes found in the “Remarks” Column are listed below. Other additional notes needed to describe the item can also be shown.

Assembly/Kit — All items on the parts list with the same unique symbol will be included when this item is purchased.

Indicated by:

“INCLUDES ITEMS W/(unique symbol)”

Serial Number Break — Used to list an effective serial number range where a particular part is used.

Indicated by:

“S/N XXXXX AND BELOW”

“S/N XXXX AND ABOVE”

“S/N XXXX TO S/N XXX”

Specific Model Number Use — Indicates that the part is used only with the specific model number or model number variant listed. It can also be used to show a part is NOT used on a specific model or model number variant.

Indicated by:

“XXXXX ONLY”

“NOT USED ON XXXX”

“Make/Obtain Locally” — Indicates that the part can be purchased at any hardware shop or made out of available items. Examples include battery cables, shims, and certain washers and nuts.

“Not Sold Separately” — Indicates that an item cannot be purchased as a separate item and is either part of an assembly/kit that can be purchased, or is not available for sale through Multiquip.

SUGGESTED SPARE PARTS

MVCe64V PLATE COMPACTOR WITH HONDA GXE2.0H ELECTRIC MOTOR

1 to 3 units

Qty.	P/N	Description
1.....	070100312.....	V-BELT
2.....	939010254.....	SHOCK ABSORBER
1.....	421220330.....	SWITCH BOX
2.....	1N4218A0003.....	LAMP ASSEMBLY, IND (ORANGE)
2.....	1N4228A0003.....	LAMP ASSEMBLY, IND (RED)
2.....	1N4238A0003.....	LAMP ASSEMBLY, IND (GREEN)
1.....	MCB7210.....	RECHARGEABLE BATTERY
1.....	MCB0190.....	BATTERY CHARGER
1.....	912721601.....	ELECTRIC MOTOR

NOTICE

Part numbers on this Suggested Spare Parts list may supersede/replace the part numbers shown in the following parts lists.

NAMEPLATE AND DECALS ASSY.

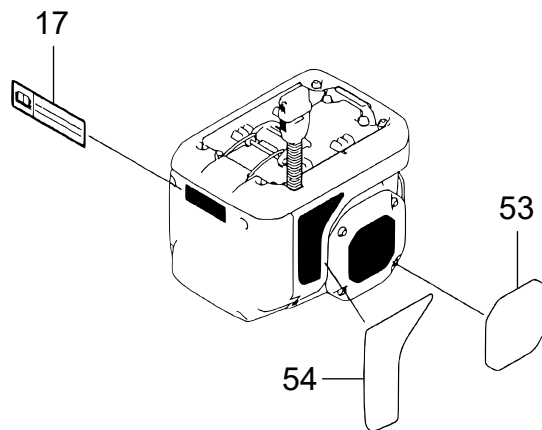
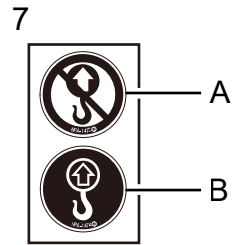
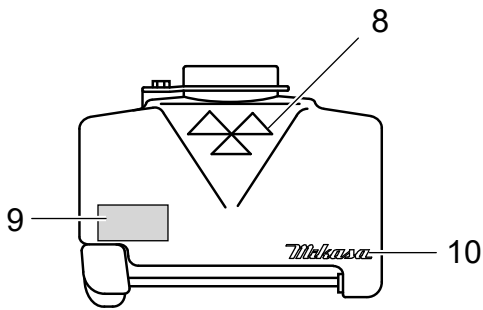
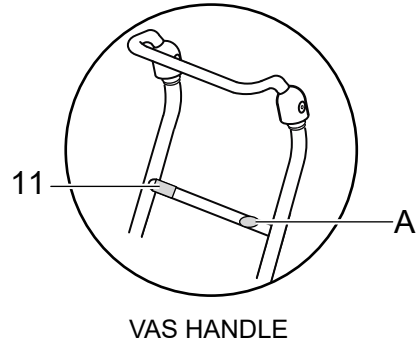
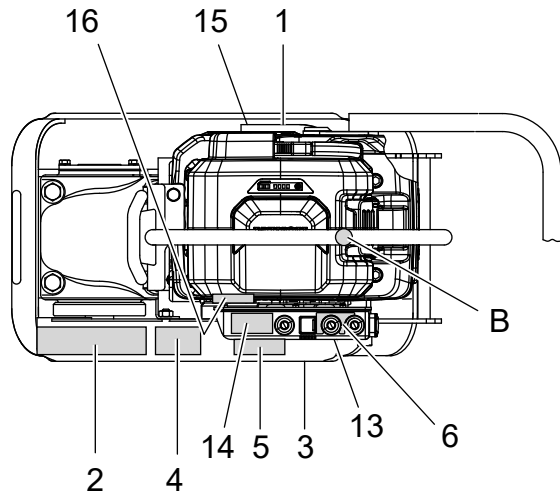

NAMEPLATE AND DECALS ASSY.

<u>NO.</u>	<u>PART NO.</u>	<u>PART NAME</u>	<u>QTY.</u>	<u>REMARKS</u>
1	920224570	PLATE; SERIAL NO./E64V/MQ	1.....	NPA-2457
1	920224580	PLATE; SERIAL NO./E64VW/MQ	1.....	NPA-2458
2	920224710	DECAL; MVC-E64	1.....	NPA-2471
3	920207590	DECAL; V-BELT (RPF-3310)	1.....	NPA-759
4	920224350	DECAL; CAUTION /COMBI./E60.....	1.....	NPA-2435
5	920224360	DECAL; START-STOP/EGX	1.....	NPA-2436
6	920224390	DECAL; LED/E60.....	1.....	NPA-2439
7	920900180	DECAL; SET TWO KINDS.....	1.....	NPA-1473, 74
8	920113140	DECAL; MIKASA (BLACK, 40X80).....	1.....	NP-1314
9	920201580	DECAL; MQ MARK 71X55	1.....	NPA-158
10	920114000	DECAL; MIKASA (125 MM) BLACK	1.....	NP-1400
11	920220740	DECAL; HANDLE ASSEMBLY/CAUTION	1	NPA-2074
13	920224690	DECAL; EARTH SMART	1	NPA-2469
14	920222240	DECAL; PROPOSITION 65.....	1	NPA-2224
15	920224750	DECAL; MQ, 3 YEAR WARRANTY	1	NPA-2475
16	920224760	DECAL; CAUTION RAINY AND WASH.....	1	NPA-2476
17	875168A0620	MARK; OPER CAUTION (E)	1	HONDA
53	875218A0600	MARK; EMBLEM	1	HONDA
54	875238A0600	MARK; ELECTRIC PW	1	HONDA

BODY ASSY.

<u>NO.</u>	<u>PART NO.</u>	<u>PART NAME</u>	<u>QTY.</u>	<u>REMARKS</u>
1	418118545OR	VIBRATORY PLATE, 570X350	1	
2	421220320OR	BASE-OR	1	
3	939010254	SHOCK ABSORBER	4	REPLACES P/N 939010400
4	959404350	EARTH WIRE	1	
5	020310080	NUT M10	8	
6	030210250	WASHER, LOCK M10	8	
7	031110160	WASHER, FLAT M10	4	
12	421473480	BOLT, ENGINE	1	
13	413436870	NUT, REAR ENGINE	1	
14-1	011208025	BOLT, 8X25	2	REPLACES P/N 001220825
14-2	030208200	WASHER, LOCK M8	2	
14-3	0401450080	WASHER, FLAT M8	2	REPLACES P/N 031108160
16	0401450080	WASHER, FLAT M8	1	REPLACES P/N 031108160
17	022710809	NUT, NYLON M8	1	
18	404418150	SPACER, CLUTCH 18X25X8	1	
19	460446780	CLUTCH ASSEMBLY	1	INCLUDES ITEMS W/\$
19-1\$	943920080	CLUTCH, SHAFT	1	
19-2\$	941010400	CLUTCH PULLEY	1	
19-6\$	080200300	SNAP RING	1	
19-7\$	080600550	CLIP	1	
19-8\$	042006006	BEARING	1	REPLACES P/N 046006006
20	0320050150	KEY, 5X5X35	1	REPLACES P/N 951400100
21	952400130	SPACER	1	
22-1	011208025	BOLT, 8X25	1	REPLACES P/N 001220825
22-2	030208200	WASHER, LOCK M8	1	
23	070100312	V-BELT RPF-3310	1	
25	418216470	BELT COVER	1	
26-1	012210035	BOLT, 10X35	1	REPLACES P/N 001221035
26-2	030210250	WASHER, LOCK M10	1	
26-3	031110160	WASHER, FLAT M10	1	
27	418216480	BELT COVER (IN)	1	
28-1	001221053	BOLT, 10X65	1	
28-2	030210250	WASHER, LOCK M10	1	
28-3	031110160	WASHER, FLAT M10	1	
31	020108060	NUT M8	2	REPLACES P/N 020308060
32	030208200	WASHER, LOCK M8	2	
33	0401450080	WASHER, FLAT M8	2	REPLACES P/N 031108160

BODY ASSY. (CONT'D.)

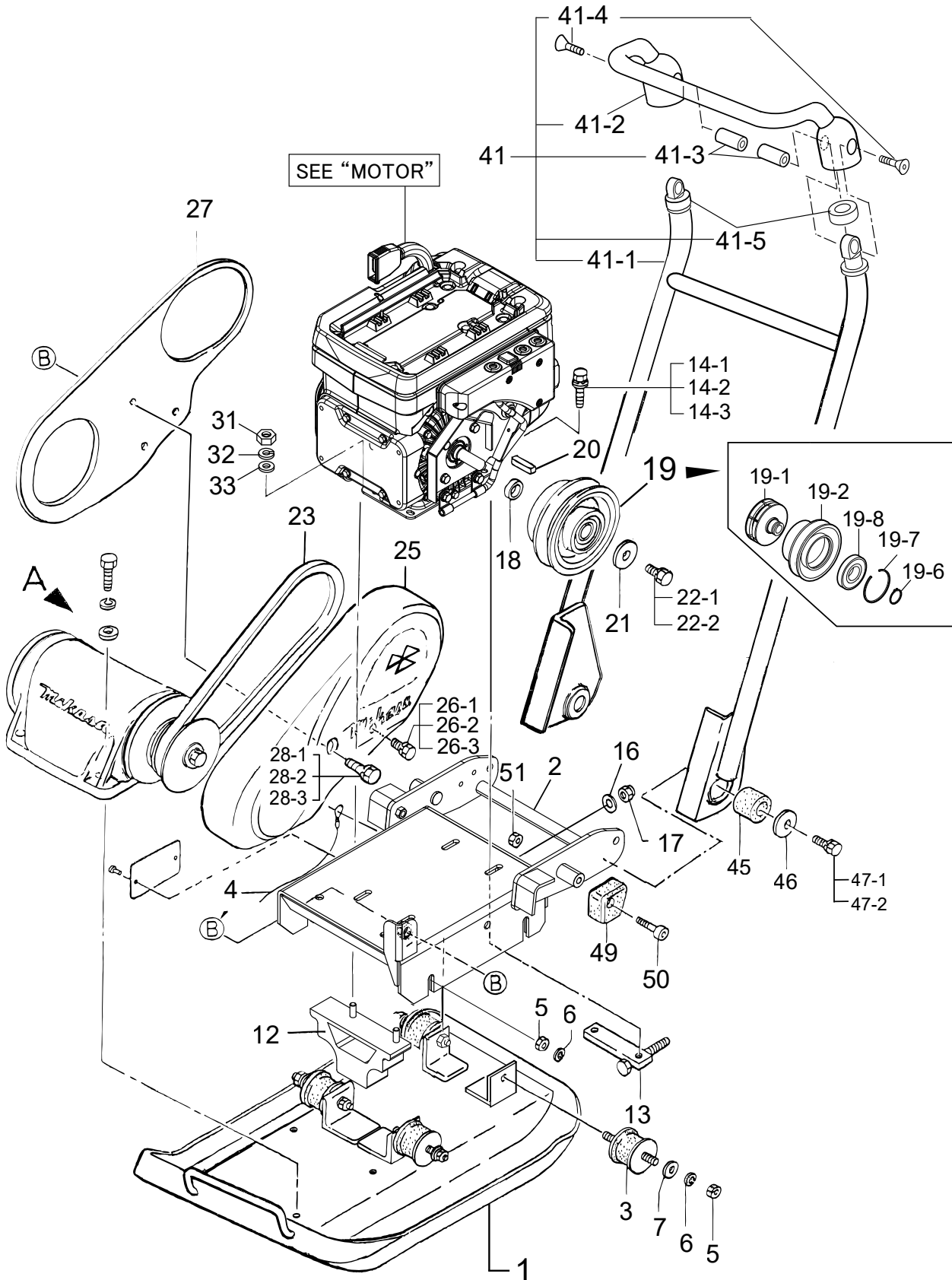

BODY ASSY. (CONT'D.)

<u>NO.</u>	<u>PART NO.</u>	<u>PART NAME</u>	<u>QTY.</u>	<u>REMARKS</u>
41	418910120	VAS HANDLE ASSEMBLY.....	1.....	INCLUDES ITEMS W/#
41-1#	418217051	VAS HANDLE BODY	1	
41-2#	418217060	GRIP, HANDLE	1	
41-3#	416459320	THREADED NUT, HANDLE	2	
41-4#	416459341	RUBBER, VAS HANDLE	2	
41-5#	009120407	BOLT, SUNK HEAD 10X20	2	
45	404433430	RUBBER, 20X32X28.5	2	
46	952403450	WASHER, 11X35X4.5	2	
47-1	012210020	BOLT, 10X20.....	2.....	REPLACES P/N 001221020
47-2	030210250	WASHER, LOCK M10	2	
49	413436720	HANDLE, RUBBER	2	
50	009110052	SOCKET HEAD BOLT, 8X45	2	
51	020108060	NUT, M8.....	2.....	REPLACES P/N 020308060

ELECTRIC MOTOR ASSY.

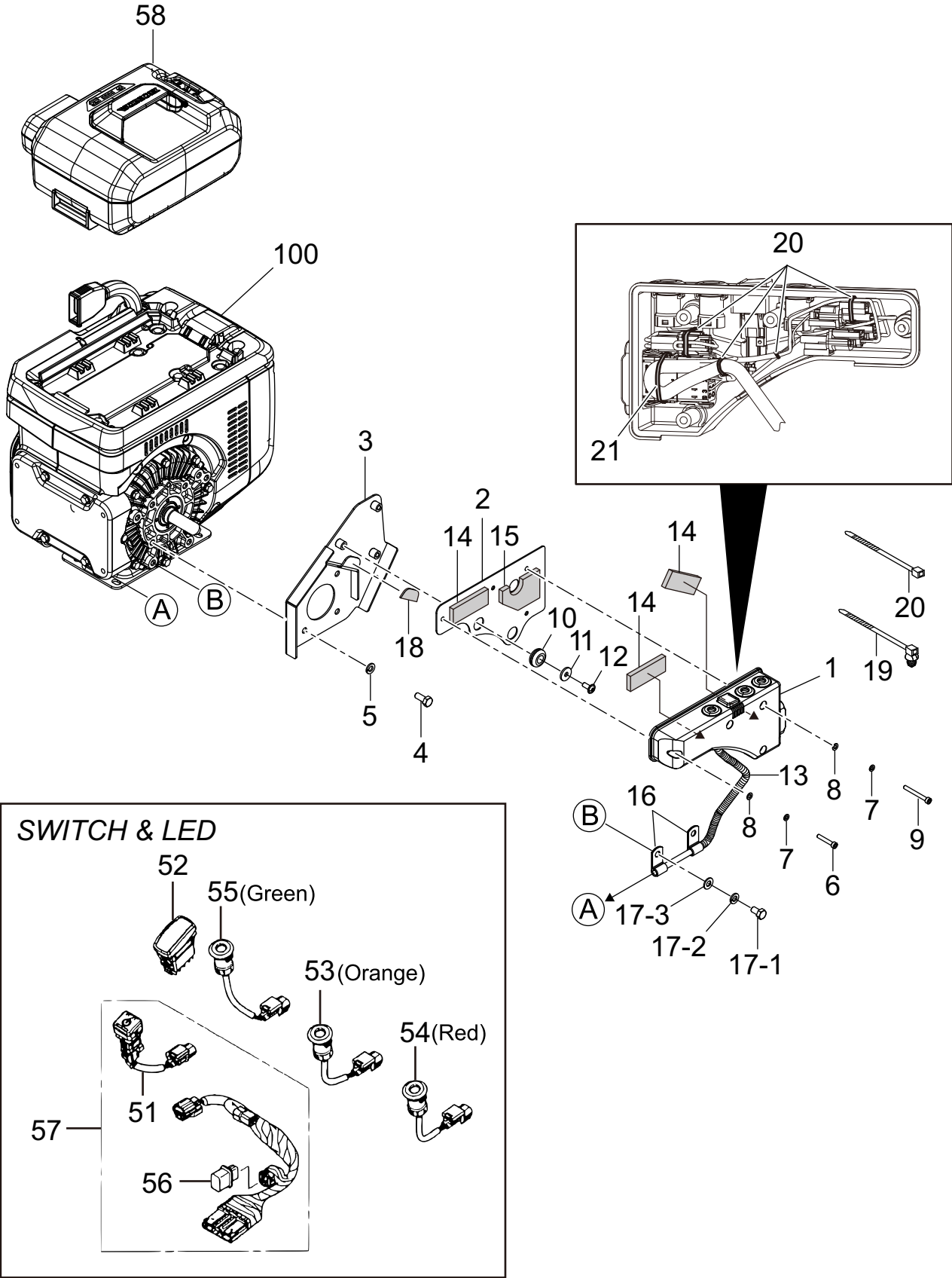

ELECTRIC MOTOR ASSY.

<u>NO.</u>	<u>PART NO.</u>	<u>PART NAME</u>	<u>QTY.</u>	<u>REMARKS</u>
1	421220330	SWITCH BOX	1	
2	421357130	SWITCH BOX PANEL	1	
3	421357140	SWITCH BOX HOLDER	1	
4	001220820	HEX HEAD BOLT, 8X20	4	
5	030208200	WASHER, LOCK M8	4	
6	001520530	SOCKET HEAD BOLT, 5X30	1	
7	030205130	WASHER, LOCK M5	4	
8	58151	WASHER, FLAT M5.....	4	REPLACES P/N 031105080
9	001520545	SOCKET HEAD BOLT, 5X45	3	
10	421473460	GROMMET	3	
11	952410670	WASHER, 6.5X20X2.3	3	
12	009110117	SOCKET HEAD SCREW, 6X15	3	
13	952410680	CORRUGATE TUBE, 10MM-250L	1	
14	421473430	CUSHION, 30X80	3	
15	421473440	CUSHION, 55X85	1	
16	959408920	CLIP 8 (M8)	2	
17-1	011008015	BOLT, 8X15.....	2	REPLACES P/N 001220815
17-2	030208200	WASHER, LOCK M8	2	
17-3	0401450080	WASHER, FLAT M8.....	2	REPLACES P/N 031108160
18	421473450	CUSHION (WASHER, LOCK-BOX HOLDER)	1	
19	421010010	FIR TREE TIE	1	
20	454010020	CLAMP, TC-100	8	
21	507010110A	CLAMP, TC-200.....	1	REPLACES P/N 507010110
51\$	1N3118A0003	SWITCH ASSEMBLY, POWER	1	
52	1N3308A0003	SWITCH ASSEMBLY, START	1	
53	1N4218A0003	LAMP ASSEMBLY, IND (ORANGE)	1	
54	1N4228A0003	LAMP ASSEMBLY, IND (RED)	1	
55	1N4238A0003	LAMP ASSEMBLY, IND (GREEN)	1	
56\$	32107ZVL003	TERMINATOR ASSEMBLY	1	
57	321358A0PA0	CORD, PC F.....	1	INCLUDES ITEMS W/\$
58	MCB7210	BATTERY PACK, LITHIUM-ION 72V 10AH	1	
100	912721601	HONDA GXE2.0H ELEC. MOTOR (INTEGR.)	1	

BATTERY TRAY ASSY.

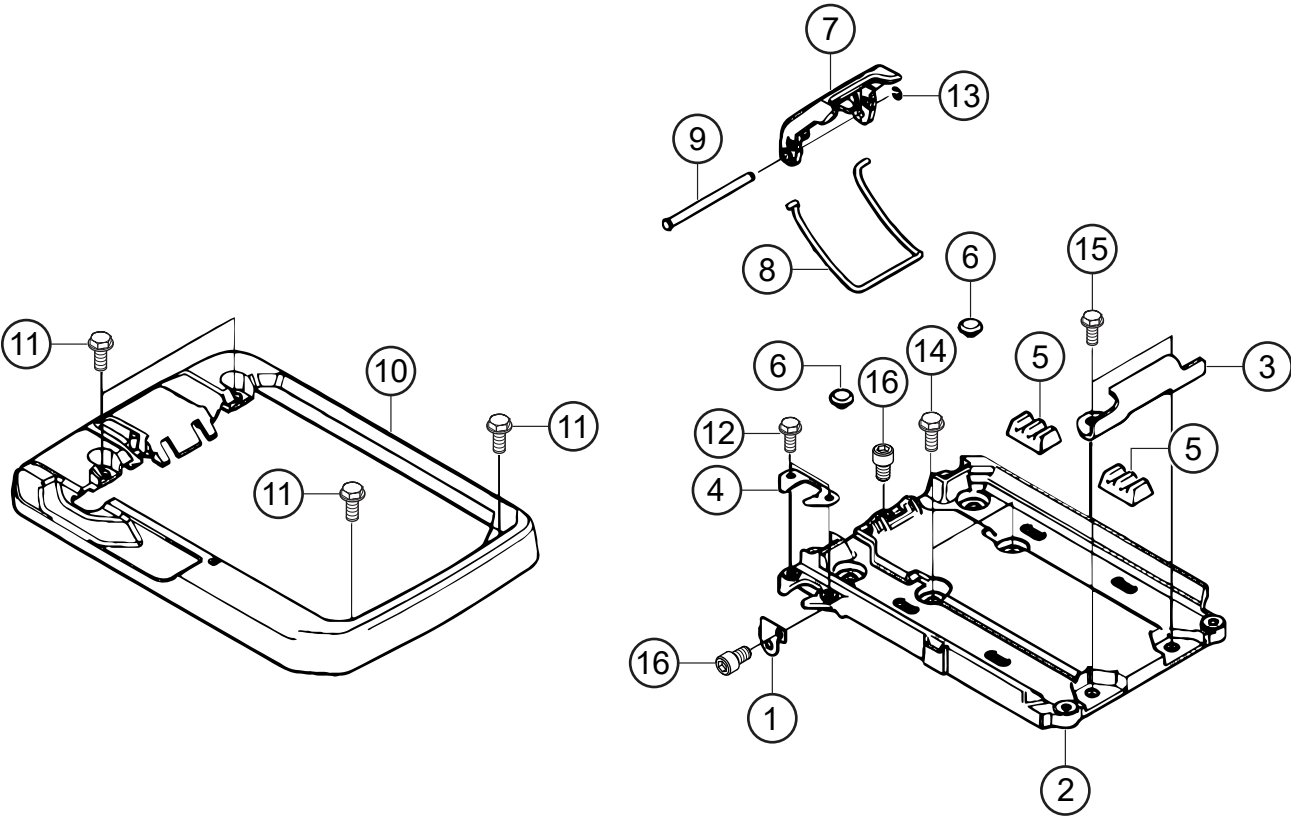

BATTERY TRAY ASSY.

<u>NO.</u>	<u>PART NO.</u>	<u>PART NAME</u>	<u>QTY.</u>	<u>REMARKS</u>
1	1F2228A0600	BRACKET, HARN CLIP A	1	
2	601058A0000	TRAY, BATTERY	1	
3	601078A0000	HOOK, BATTERY	1	
4	601238A0600	STAY, CONNECTOR	1	
5	608018A0000	RUBBER, BATTERY MOUNT	4	
6	608068A0600	CAP, HOLE 8MM	2	
7	609028A0000ZA	LAVER, FASTENER	1	
8	609038A0000	WIRE, FASTENER	1	
9	609048A0000	PIN, LOCK LEVER	1	
10	611058A0600ZB	COVER, BATTERY TRAY NH1 (BLACK)	1	
11	900028A0000	BOLT, SPECIAL 6X16	4	
12	90007892000	BOLT, FLANGE 5X12	2	
13	9454004018	E RING, 4	1	
14	957010801608	BOLT, FLANGE 8X16	2	
15	957010802008	BOLT, FLANGE 8X20	2	
16	966000601208	BOLT, SOCKET 6X12	2	

BATTERY CHARGER ASSY.

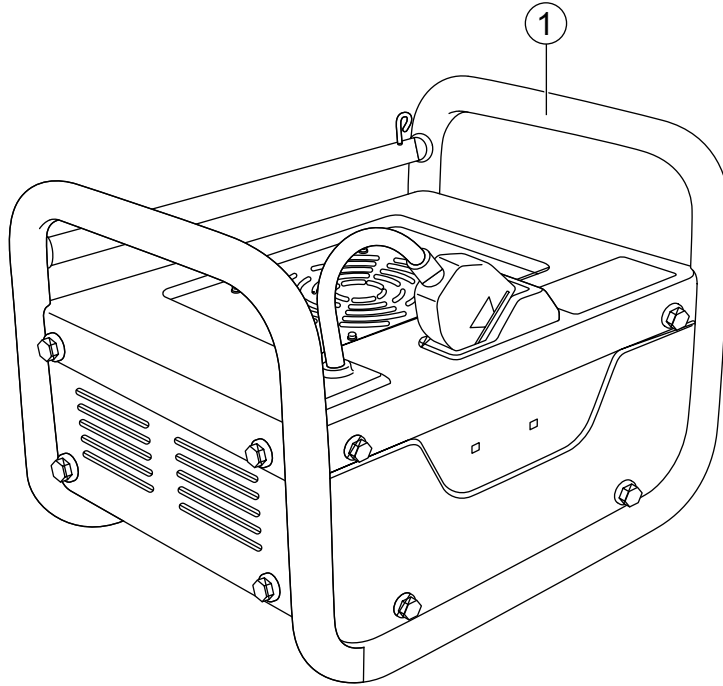

BATTERY CHARGER ASSY.

<u>NO.</u>	<u>PART NO.</u>	<u>PART NAME</u>	<u>QTY.</u>	<u>REMARKS</u>
1	MCB0190	BATTERY CHARGER	1	

WATER TANK ASSY. (OPTION)

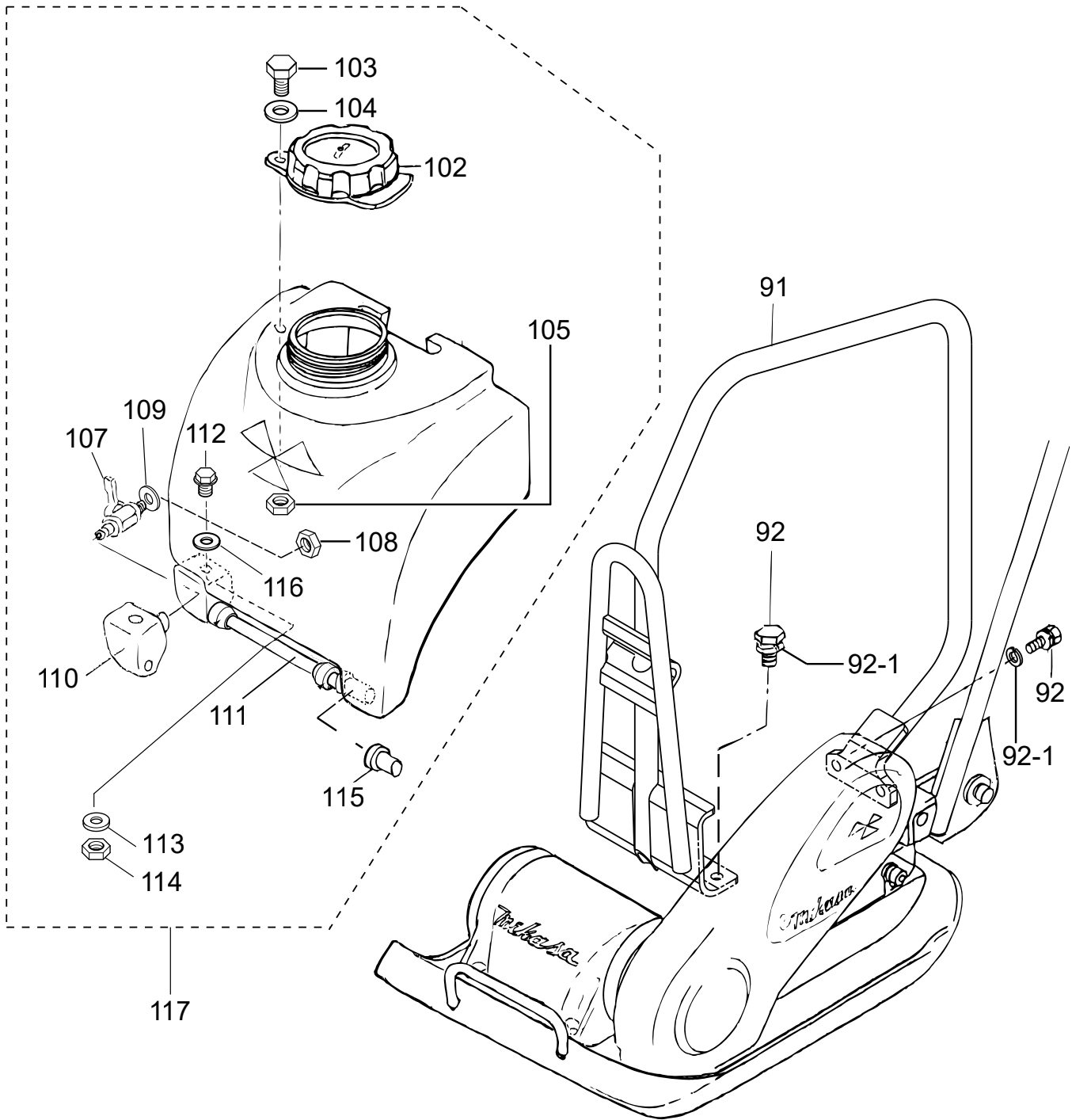

WATER TANK ASSY. (OPTION)

<u>NO.</u>	<u>PART NO.</u>	<u>PART NAME</u>	<u>QTY.</u>	<u>REMARKS</u>
91	421122890	GUARD HOOK	1	
92	0105091025	BOLT, 10X25.....	4	REPLACES P/N 001221025
92-1	030210250	WASHER, LOCK M10	4	
102#	954300343	CAP, WATER TANK	1	
103#	001241030	BOLT, 10X30	1	
104#	033910160	WASHER, FLAT M10	2	
105#	022910270	NUT, M10	1	
107#	954403241	COCK PT 1/4, BH-1211AL/R	1	
108#	959403790	LOCKNUT, PS-1/4	1	
109#	953408270	PACKING, 11.5X19.5X1	1	
110#	416338940	HOLDER, PIPE (L)	1	
111#	418344110	SPRINKLING, PIPE	1	
112#	001740825	FLANGE BOLT, 8X25	1	
113#	030208200	WASHER, FLAT M8.....	1	REPLACES P/N 033910110
114#	020108060	NUT, M8.....	1	REPLACES P/N 020308064
115#	418457010	CAP, RUBBER	1	
116#	953407410	PACKING, 8X15X2	1	
117	52677	WATER TANK KIT.....	1	INCLUDES ITEMS W/#

TRANSPORT WHEEL ASSY. (OPTION)

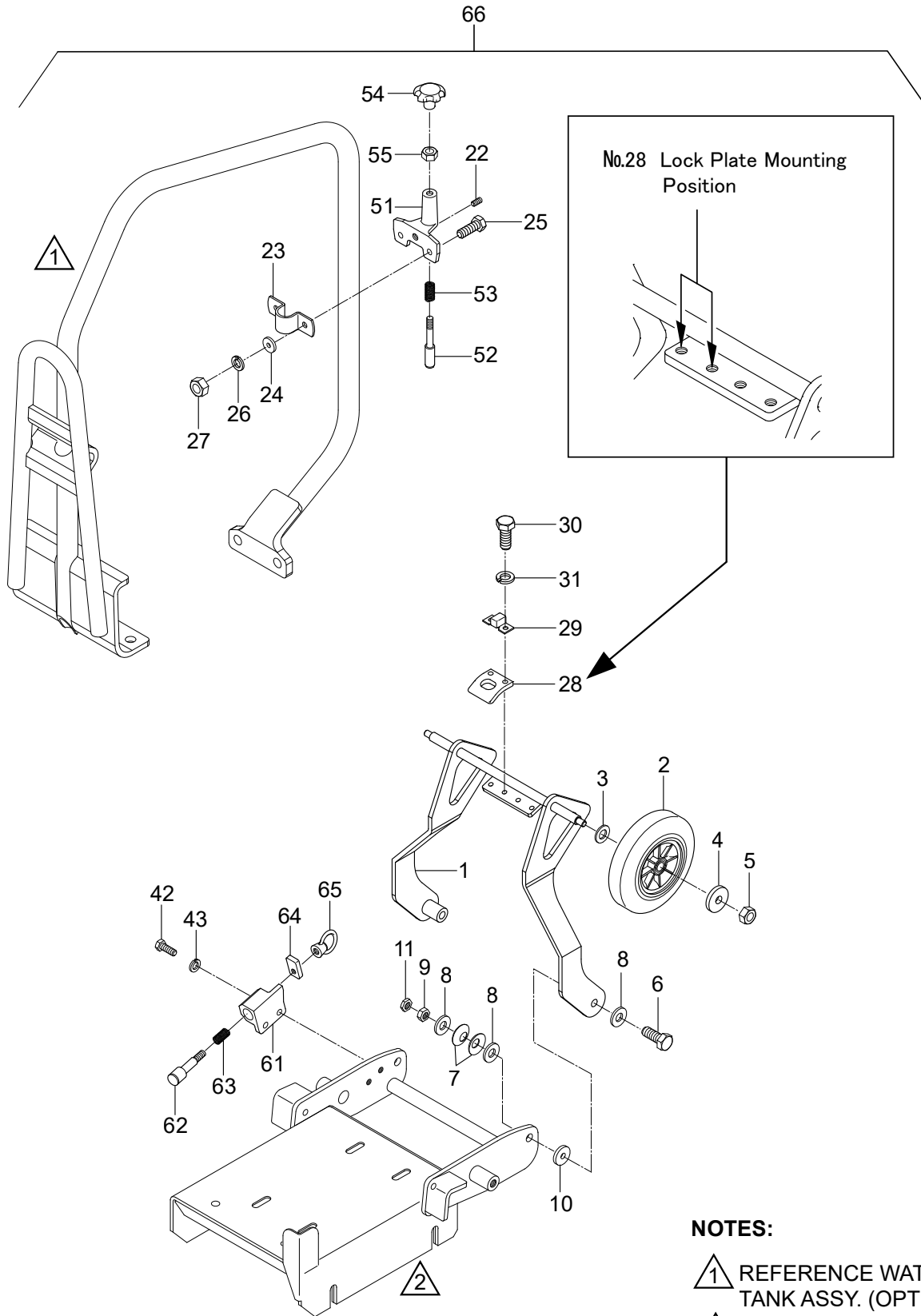

NOTES:

- ① REFERENCE WATER TANK ASSY. (OPTION)
- ② REFERENCE BODY ASSY.

TRANSPORT WHEEL ASSY. (OPTION)

<u>NO.</u>	<u>PART NO.</u>	<u>PART NAME</u>	<u>QTY.</u>	<u>REMARKS</u>
1#	421357120	FRAME AXLE, CART	1	
2#	959301000	WHEEL, 12.2DX130X42B/T90	2	
3#	031112230	WASHER, FLAT M12	2	
4#	952402610	WASHER, 8.5X25X3	2	
5#	020108060	NUT, M8	2	REPLACES P/N 020308060
6#	012210035	BOLT, 10X35	2	REPLACES P/N 001221035
7#	032110180	CONICAL LOCK WASHER, M10	4	
8#	031110160	WASHER, FLAT M10	6	
9#	020310080	NUT, M10	2	
10#	031110160	WASHER, 11X25X3.2	2	REPLACES P/N 952401440
11#	020310080	NUT, M10	2	REPLACES P/N 020410060
22#	098208008	SOCKET HEAD BOLT, 8X8	1	
23#	418467140	SUPPORT FITTING, PIPE	1	
24#	952401690	WASHER, 6.5X17X3	2	
25#	011206020	BOLT, 6X20	2	REPLACES P/N 001220620
26#	030206150	WASHER, LOCK M6	2	
27#	020106050	NUT, M6	2	REPLACES P/N 020306050
28#	418467270	LOCK PLATE, V-AXLE	1	
29#	418467150	STOPPER RUBBER	1	
30#	001220616	BOLT, 6X16	2	
31#	030206150	WASHER, LOCK M6	2	
42#	011008015	BOLT, 8X15	2	REPLACES P/N 001220815
43#	030208200	WASHER, LOCK M8	2	
51#	418352500	LOCK BRACKET	1	
52#	418467260	STOPPER, PIN L-BRACKET	1	
53#	458450880	SPRING	1	
54#	959408900	KNOB, M8	1	
55#	020408050	NUT, M8	1	
61#	418352520	STOPPER BRACKET	1	
62#	418467290	STOPPER PIN, HANDLE	1	
63#	418467160	SPRING, STOPPER	1	
64#	418467280	STOPPER, S-BRACKET	1	
65#	959010412	EYE NUT, M8	1	
66	WHLE64	WHEEL KIT	1	INCLUDES ITEMS W/# CONTACT SALES DEPT.

VIBRATOR ASSY.

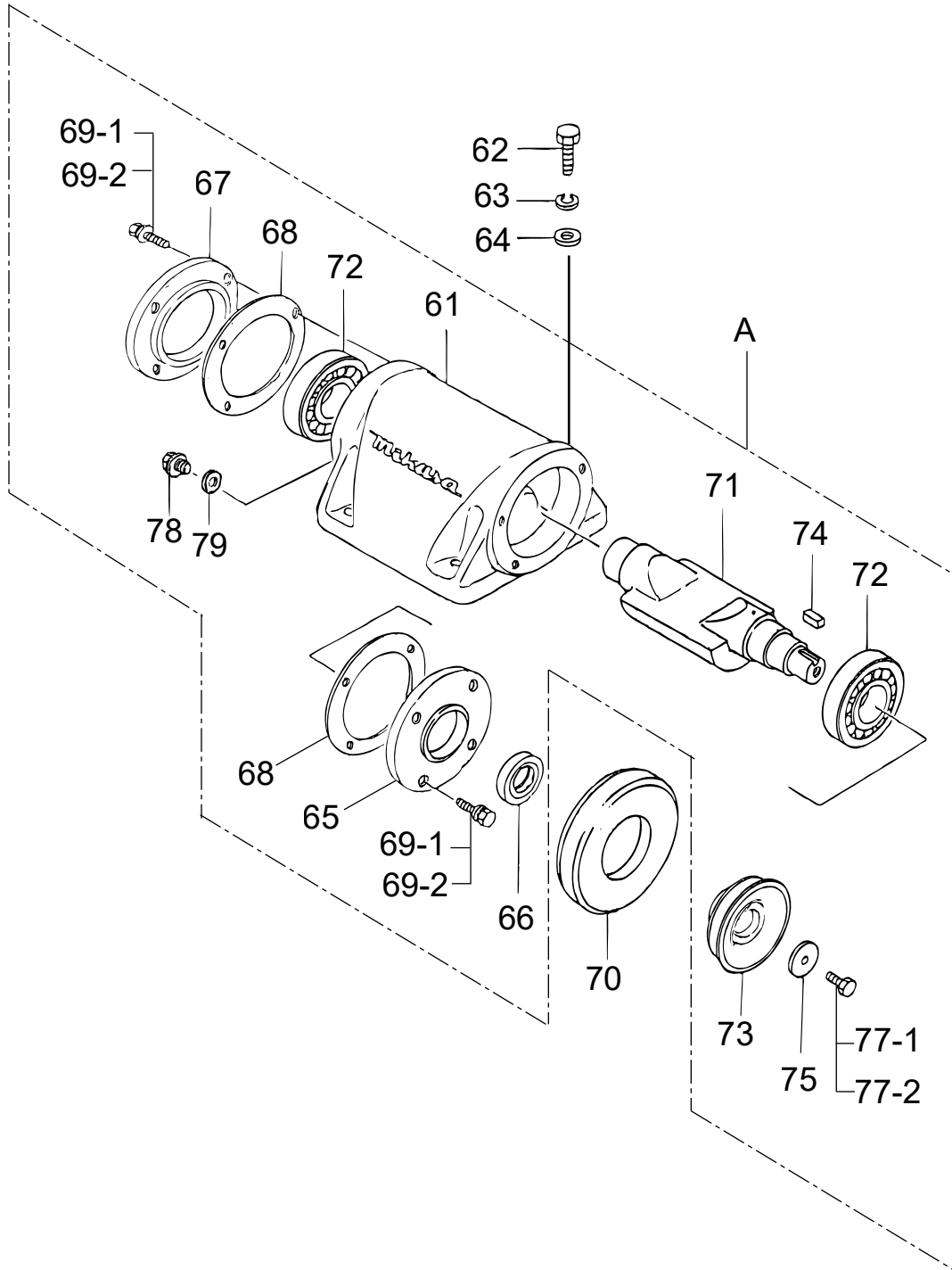

VIBRATOR ASSY.

<u>NO.</u>	<u>PART NO.</u>	<u>PART NAME</u>	<u>QTY.</u>	<u>REMARKS</u>
A	418910049OR	VIBRATING CASE ASSEMBLY	1.....	INCLUDES ITEMS W/\$
61\$	418117739OR	VIBRATING CASE	1	
62\$	001221445	BOLT, 14X45	4	
63\$	030214350	WASHER, LOCK M14	4	
64\$	031114260	WASHER, FLAT M14	4	
65\$	418464310	CASE COVER, PULLEY	1	
66\$	060403020	SEAL, OIL TC-30458	1	
67\$	418456960	CASE COVER, SHUT OFF	1	
68\$	418456971	PACKING	2	
69-1\$	001220820	BOLT, 8X20	8	
69-2\$	030208200	WASHER, LOCK M8	8	
70	418464511	COVER SEAL, VIB.	1	
71\$	418343400	ECC. ROTOR SHAFT	1	
72\$	040306307	BEARING.....	2.....	REPLACES P/N 040406307
73\$	418456981	PULLEY, VIB.	1	
74\$	951401920	KEY, 7X7X30	1	
75\$	952403450	WASHER, 11X35X4.5	1	
77-1\$	012010030	BOLT, 10X30.....	1.....	REPLACES P/N 001221030
77-2\$	030210250	WASHER, LOCK M10	1	
78\$	953400270	PLUG, 1/4X14 10L	1	
79\$	953405260	PACKING, 1/4 (CU)	1	

PARTS MANUAL

HERE'S HOW TO GET HELP

PLEASE HAVE THE MODEL AND SERIAL
NUMBER ON-HAND WHEN CALLING

UNITED STATES

Multiquip Inc.

(310) 537- 3700
6141 Katella Avenue Suite 200
Cypress, CA 90630
E-MAIL: mq@multiquip.com
WEBSITE: www.multiquip.com

CANADA

Multiquip

(450) 625-2244
4110 Industriel Boul.
Laval, Quebec, Canada H7L 6V3
E-MAIL: infocanada@multiquip.com

UNITED KINGDOM

Multiquip (UK) Limited Head Office

0161 339 2223
Unit 2, Northpoint Industrial Estate,
Globe Lane,
Dukinfield, Cheshire SK16 4UJ
E-MAIL: sales@multiquip.co.uk

© COPYRIGHT 2026, MULTIQUIP INC.

Multiquip Inc. and the MQ logo are registered trademarks of Multiquip Inc. and may not be used, reproduced, or altered without written permission. All other trademarks are the property of their respective owners and used with permission.

This manual MUST accompany the equipment at all times. This manual is considered a permanent part of the equipment and should remain with the unit if resold.

DISCLAIMER: Product features, descriptions, and specifications are based on published information at the time of publication and are subject to change at any time without notice. Multiquip Inc. and its affiliates reserve the right to change specifications, features, design, and descriptions of products at any time without notice.

