

OPERATION MANUAL



Mikasa **SERIES**
MODEL MVCe64V
ONE-WAY PLATE COMPACTOR
(HONDA GXE2.0H DC POWER UNIT
HONDA DP72104Z BATTERY)

Revision #0 (06/28/21)

To find the latest revision of this publication or
associated parts manual, visit our website at:
www.multiquip.com



THIS MANUAL MUST ACCOMPANY THE EQUIPMENT AT ALL TIMES.

PROPOSITION 65 WARNING



**MVCe64V
Plate Compactor**

Proposition 65 Warning 2
Safety Information 4-6
Specifications 8-9
Dimensions..... 10
General Information..... 11
Components 12-13
Inspection 14-15
Wheel Kit (Optional) 16-17
Operation..... 18-19
Maintenance 20-21
Long Term Storage 22
Troubleshooting 23
Wiring Diagram..... 24

NOTICE

Specifications and part numbers are subject to change without notice.

SAFETY INFORMATION

Do not operate or service the equipment before reading the entire manual. Safety precautions should be followed at all times when operating this equipment. Failure to read and understand the safety messages and operating instructions could result in injury to yourself and others.



SAFETY MESSAGES

The four safety messages shown below will inform you about potential hazards that could injure you or others. The safety messages specifically address the level of exposure to the operator and are preceded by one of four words: **DANGER**, **WARNING**, **CAUTION** or **NOTICE**.

SAFETY SYMBOLS

! DANGER

Indicates a hazardous situation which, if not avoided, **WILL** result in **DEATH** or **SERIOUS INJURY**.

! WARNING

Indicates a hazardous situation which, if not avoided, **COULD** result in **DEATH** or **SERIOUS INJURY**.

! CAUTION

Indicates a hazardous situation which, if not avoided, **COULD** result in **MINOR** or **MODERATE INJURY**.

NOTICE

Addresses practices not related to personal injury.

Potential hazards associated with the operation of this equipment will be referenced with hazard symbols which may appear throughout this manual in conjunction with safety messages.

Symbol	Safety Hazard
	Lethal exhaust gas hazards
	Explosive fuel hazards
	Burn hazards
	Respiratory hazards
	Accidental starting hazards
	Eye and hearing hazards
	Rotating parts hazards

SAFETY INFORMATION

GENERAL SAFETY

CAUTION

- **NEVER** operate this equipment without proper protective clothing, shatterproof glasses, respiratory protection, hearing protection, steel-toed boots and other protective devices required by the job or city and state regulations.



- **NEVER** operate this equipment when not feeling well due to fatigue, illness or when under medication.



- **NEVER** operate this equipment under the influence of drugs or alcohol.



- **ALWAYS** check the equipment for loosened threads or bolts before starting.
- **DO NOT** use the equipment for any purpose other than its intended purposes or applications.
- **ALWAYS** clear the work area of any debris, tools, etc. that would constitute a hazard while the equipment is in operation.

NOTICE

- This equipment should only be operated by trained and qualified personnel 18 years of age and older.
- Whenever necessary, replace nameplate, operation and safety decals when they become difficult read.
- Manufacturer does not assume responsibility for any accident due to equipment modifications. Unauthorized equipment modification will void all warranties.
- **NEVER** use accessories or attachments that are not recommended by Multiquip for this equipment. Damage to the equipment and/or injury to user may result.
- **ALWAYS** know the location of the nearest **fire extinguisher**.
- **ALWAYS** know the location of the nearest **first aid kit**.
- **ALWAYS** know the location of the nearest phone or **keep a phone on the job site**. Also, know the phone numbers of the nearest **ambulance**, **doctor** and **fire department**. This information will be invaluable in the case of an emergency.



SAFETY INFORMATION

COMPACTOR SAFETY

DANGER

- **NEVER** operate the equipment in an explosive atmosphere or near combustible materials. An explosion or fire could result causing severe **bodily harm or even death.**



WARNING

- **NEVER** disconnect any **emergency or safety devices.** These devices are intended for operator safety. Disconnection of these devices can cause severe injury, bodily harm or even death. Disconnection of any of these devices will void all warranties.

CAUTION

- **NEVER** lubricate components or attempt service on a running machine.

NOTICE

- **ALWAYS** keep the machine in proper running condition.
- Fix damage to machine and replace any broken parts immediately.
- **ALWAYS** store equipment properly when it is not being used. Equipment should be stored in a clean, dry location out of the reach of children and unauthorized personnel.

BATTERY SAFETY

CAUTION

- Remove or attach battery in a clear and flat location without any combustible materials nearby.
- After attaching the battery, make sure that the battery hook and fastener are securely attached.

DC POWER UNIT

CAUTION

- **DO NOT** touch the DC power unit during work or soon after work, because it is very hot.

TRANSPORTING SAFETY

CAUTION

- **NEVER** allow any person or animal to stand underneath the equipment while lifting.

NOTICE

- Before lifting, make sure that the equipment parts (hook and vibration insulator) are not damaged and screws are not loose or missing.
- Always make sure crane or lifting device has been properly secured to the lifting bail (hook) of the equipment.
- **ALWAYS** shutdown DC power before transporting.
- **NEVER** lift the equipment with power on.
- Use adequate lifting cable (wire or rope) of sufficient strength.
- Use one point suspension hook and lift straight upwards.
- **DO NOT** lift machine to unnecessary heights.
- **ALWAYS** tie down equipment during transport by securing the equipment with rope.

ENVIRONMENTAL SAFETY

NOTICE

- Dispose of hazardous waste properly. Examples of potentially hazardous waste are used motor oil, fuel and fuel filters.
- **DO NOT** use food or plastic containers to dispose of hazardous waste.
- **DO NOT** pour waste, oil or fuel directly onto the ground, down a drain or into any water source.



SPECIFICATIONS

Table 1. MVCe64V/VW Specifications

Centrifugal Force	2,271 lbf (10.1 kN)
Vibration Frequency	5600 vpm (93 Hz)
Lubrication Oil	API Service Categories SE or higher SAE 10W-30
Plate Size (L x W)	22.4 x 13.8 in (570 x 350 mm)
Rated Operating Time	Approximately 30 min/1.6 kW
Operating Weight (MVCe64V)	176 lbs. (80 kg)
Operating Weight (MVCe64VW)	194 lbs. (88 kg)
Vibrating Oil Capacity	0.148 quart (0.14 liter)
Water Tank Capacity (MVCe64VW)	11.6 quarts (11 liters)

Table 2. DC Power Unit Specifications

Model	Honda GXE2.OH
Type	Three-phase brushless DC motor
Weight (without battery)	40.8 lbs. (18.5 kg)
Maximum Output	2.4 HP (1.8 KW) @ 3600 R.P.M.
Voltage	72 V

Table 3. Battery Specifications

Model	Honda DP72104Z
Type	Rechargeable Lithium Ion Battery
Dimensions (L x W x H)	9.2 x 10.6 x 5.9 in (233 x 268 x 150 mm)
Weight	14.1 lbs. (6.4 kg)
Voltage	72 V
Charging Temperature Range	41 - 86 °F (5 - 30 °C)
Operating Temperature Range	41 - 104 °F (5 - 40 °C)
Storage Temperature Range	23 - 86 °F (-5 - 30 °C)

SPECIFICATIONS

Table 4. Battery Charger Specifications

Model	Honda CV7285Z
Dimensions (L x Wx H)	10.5 x 13.9 x 9.7 in (266 x 352 x 247 mm)
Weight	24.2 lbs. (11 kg)
Cable Length	78.7 in (2000 mm)
Input Voltage	100-240 VAC
Input Frequency	50/60 Hz
Output Voltage	82.8 VDC
Charging Temperature Range	41 - 86 °F (5 - 30 °C)
Charging Time: 80% 100%	1 hour 1.5 hours

Table 5. Noise and Vibration Emissions

Measured Sound Power Level in dB(A)	99
Guaranteed Sound Power Level in dB(A)	100
Guaranteed Sound Pressure Level at Operator Station in dB(A)	86
Hand-Arm Vibration in m/s ²	2.4

NOTES:

1. Products are tested for sound pressure level in accordance with European Directives 2000/14/EC and 2005/88/EC, relating to Noise Emission in the Environment by equipment for use outdoors.
2. Products are tested for hand/arm vibration (HAV) level in accordance with European Directives 2002/44/EC and EN500-4 and ISO 5349-1:2001, ISO 5349-2:2001.

DIMENSIONS

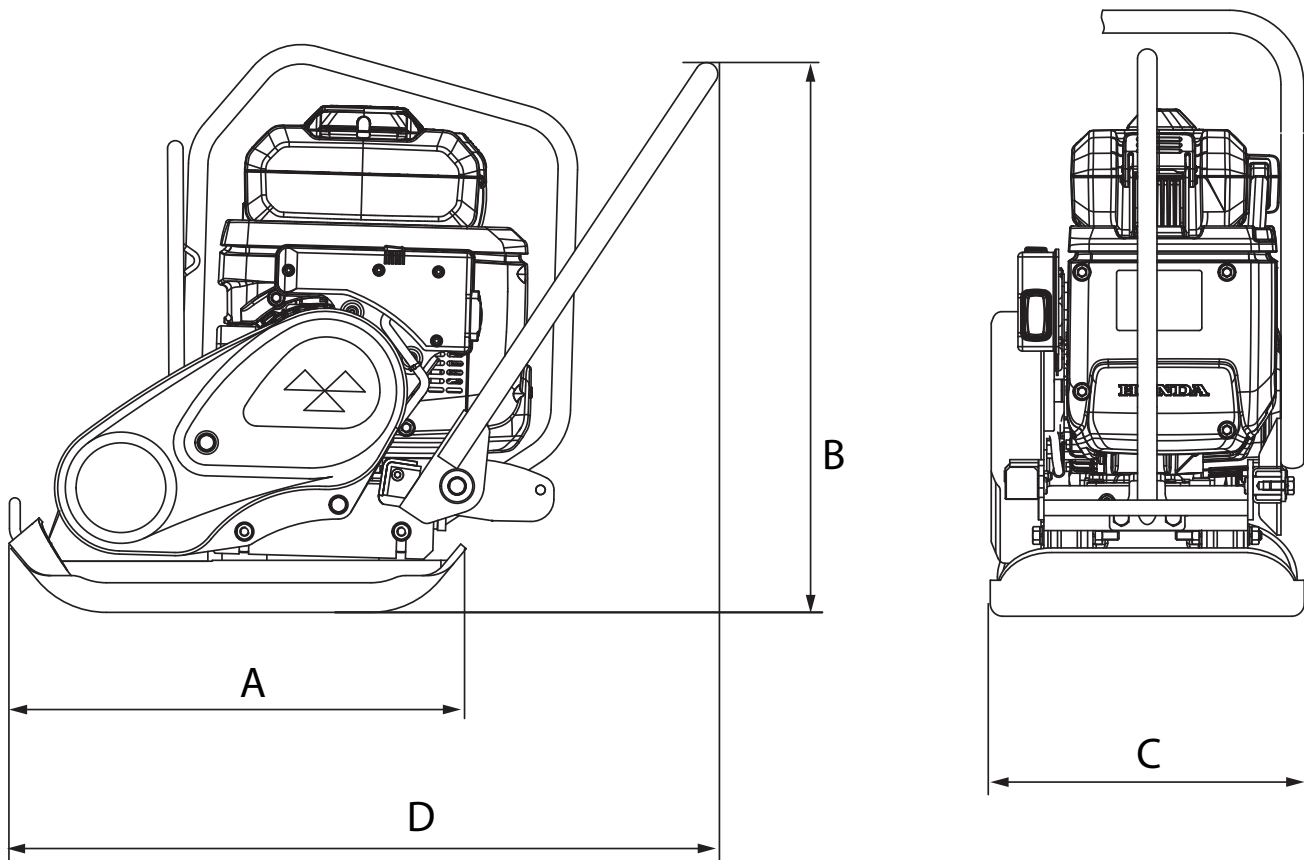

Figure 1. MVCe64V Dimensions

Table 6. Dimensions

Reference	Description	Measurement
A	Length of Plate	22.4 in (570 mm)
B	Height (including handle)	39.2 in (995 mm)
C	Width of Plate	13.8 in (350 mm)
D	Length (including handle)	36 in. (915 mm)

GENERAL INFORMATION

DEFINITION OF PLATE COMPACTOR

The Mikasa MVCe64V is a walk-behind, one-way plate compactor designed for the compaction of sand, mixed soils and asphalt. This plate compactor is a powerful compacting tool capable of applying a tremendous force in consecutive high frequency vibrations to a soil surface. Its applications include soil compacting for road, embankments and reservoirs as well as backfilling for gas pipelines, water pipelines and cable installation work.

The upper section of the plate compactor consists of the DC power unit, handle, guard hook, and belt cover. The lower section of the plate compactor consists of the vibrating plate and vibrator unit that has an eccentric rotor in vibrating case.

VIBRATORY PLATES

The vibratory plates produce low amplitude high frequency vibrations, designed to compact granular soils and asphalt.

The resulting vibrations cause forward motion. The engine and handle are vibration-isolated from the vibrating plate. The heavier the plate, the more compaction force it generates.

FREQUENCY/SPEED

The compactor's vibrating plate has a frequency of 5,600 vpm (vibrations per minute).

DC POWER UNIT

The plate compactor is equipped with a Honda GXE2.OH 3-phase brushless DC motor.

BATTERY and BATTERY CHARGER

THE MVCE64V uses a Honda DP72104Z rechargeable lithium ion battery and a Honda DV7285Z battery charger.

WATER TANK

An optional water tank can be used with this compactor. The tank provides lubrication to the base plate when compacting asphalt and may be used for dust control in dry work environments.

COMPONENTS

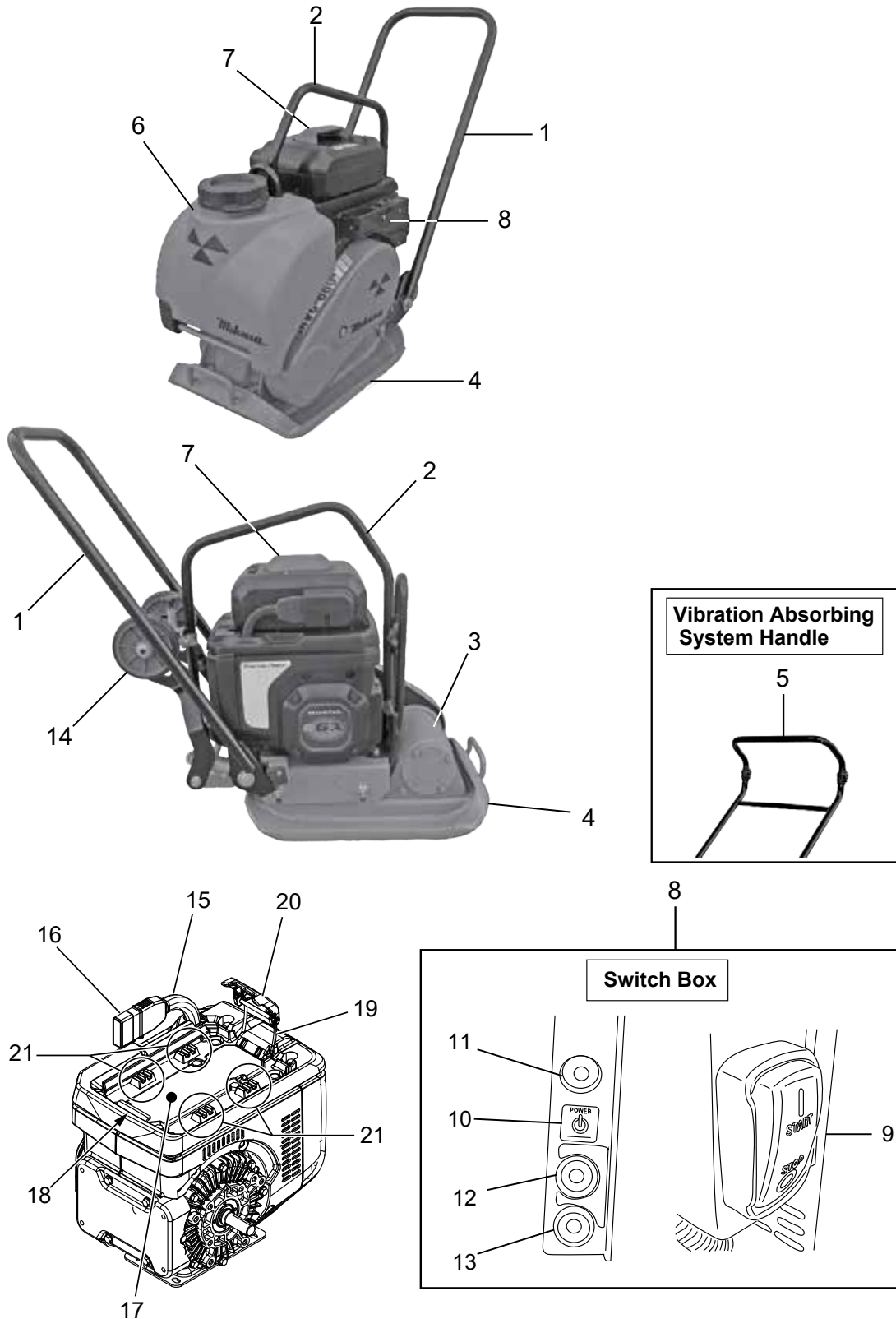

Figure 2. MVCe64V Controls and Components

COMPONENTS

Figure 2 shows the location of the basic controls and components of the MVCe64V Plate Compactor. The function of each control is described below:

1. **Handle Bar** — When operating the compactor use this handle bar to maneuver the compactor.
2. **Lifting Bale** — When lifting of the compactor is required either by forklift, crane, etc., tie rope or chain around this lifting point.
3. **Vibration Case** — Encloses the eccentric, gears and counter weights.
4. **Vibrating Plate** — A flat, open plate made of durable cast iron construction used in the compacting of soil.
5. **Vibration Absorbing System Handle** — Designed to absorb or dampen the vibration during compaction.
6. **Water Tank (Optional)** — Used when your application requires sprinkling. *Do not fill with diesel fuel or gasoline as this creates both a safety and environmental hazard!*
7. **Battery Pack** — Rechargeable Lithium Ion Batttery.
8. **Switch Box** — contains buttons and indicators to operate compactor.
9. **Start/Stop Button** — Used to start and stop unit.
10. **Power Button** — Used to turn power on and off.
11. **Power Indicator** — Lights green when the power button is pressed.
12. **Alert Indicator** — Lights orange to indicate something is wrong with rammer.
13. **Error Indicator** — Lights red when an error is detected.
14. **Wheel Kit (Optional)** — When deployed, used to move plate compactor to a different location.
15. **Power Cable** — Connects the compactor to the battery pack for power.
16. **Battery Connector Cap** — Protects the battery connector on the power cable.
17. **Battery Tray** — Holds the battery pack.
18. **Battery Hook** — Attaches the battery pack to the battery tray.
19. **Battery Fastener** — Used to hook the battery pack in place.
20. **Battery Fastener Lever** — Locks the battery fastener.
21. **Battery Support** — Where the battery pack sits on the battery tray.

BEFORE STARTING

1. Read safety instructions at the beginning of manual.
2. Clean the compactor, removing dirt and dust.
3. Check the air filter for dirt and dust. If air filter is dirty, replace air filter with a new one as required.
4. Check fastening nuts and bolts for tightness. Loosened screws or bolts due to vibration, could lead to unexpected accident.
5. Make sure that the guard hook, belt cover and shock absorbers are not damaged. If they are damaged, replace new ones.
6. Replace any missing or damaged safety and operation decals.

VIBRATOR OIL CHECK

1. To check the oil level, place the plate compactor on a level surface with the power off.
2. Remove the oil plug and visually check the oil level (Figure 3).

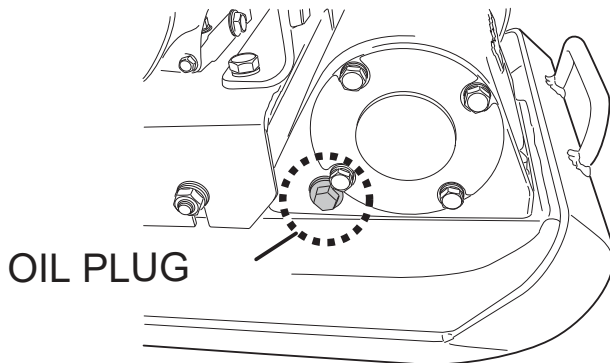

Figure 3. Oil Check

3. If the oil level is low, fill up to the oil plug with the recommended oil type (Table 7). Maximum oil capacity is 0.148 quarts (0.14 liters).

Table 7. Oil Type

Season	Temperature	Oil Type
Summer	25° C or higher	SAE 10W-30
Spring/Fall	25° C - 10° C	SAE 10W-30/20
Winter	0° C	SAE 10W-10

BATTERY PACK AND BATTERY CHARGER

NOTICE

Follow the owner's manual provided with the battery pack and battery charger for the following operations:

- Charging and Charge Level
- Cleaning
- Storage
- Disposal

NOTICE

Follow the owner's manual provided with the DC power unit when attaching and removing the battery pack.

Attaching the Battery Pack

1. Make sure there are no debris or dirt on the battery tray (Figure 4).

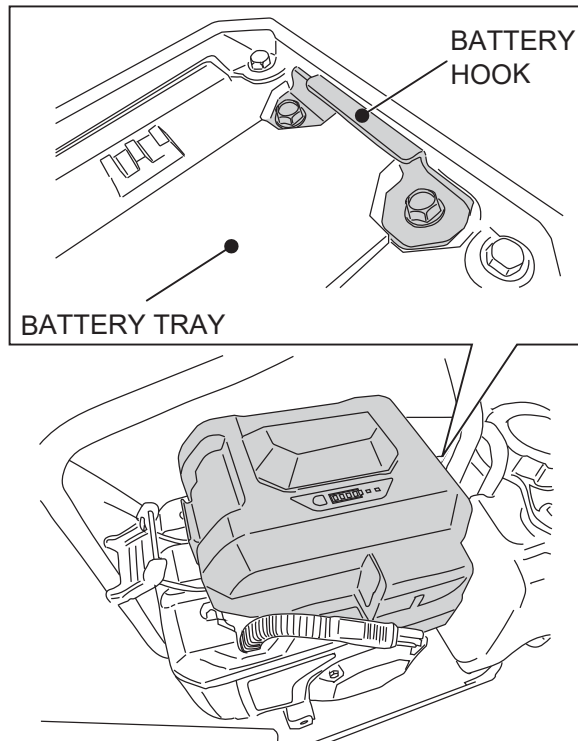

Figure 4. Battery Tray

2. Tilt the battery pack and insert its claw into the battery hook.
3. Push down the battery pack and hook the battery fastener to it (Figure 5).
4. Push the battery fastener lever up and lock the battery pack. Be careful not to catch your fingers.

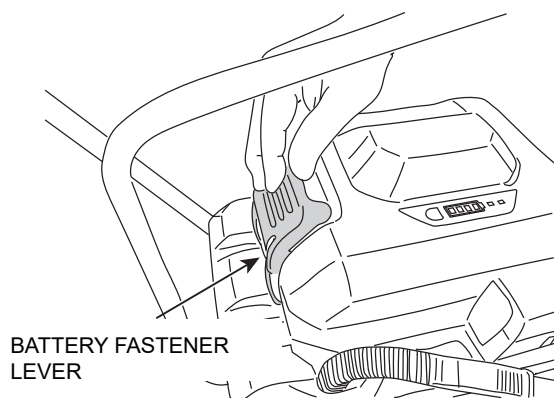

Figure 5. Battery Fastener Lever

5. Remove the battery connector cap from the power cable (Figure 6).

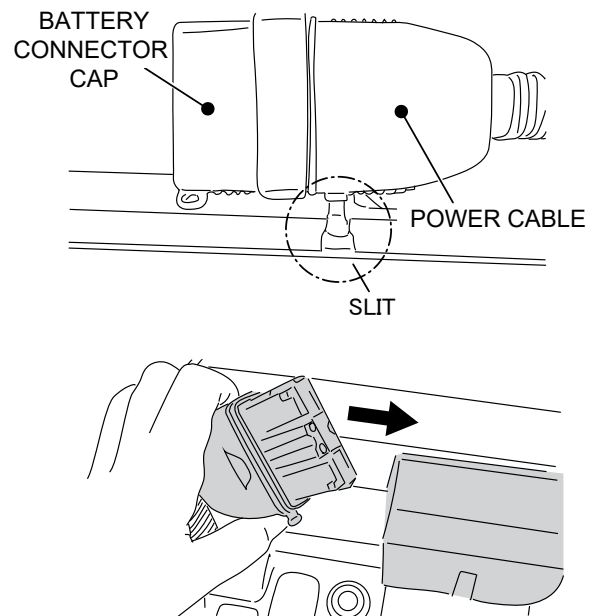

Figure 6. Battery Connector

6. Connect the power cable to the battery connector of the battery pack (Figure 6).
7. After attaching the battery pack, make sure the battery hook and fastener are securely attached.

Removing the Battery Pack

1. Remove the power cable from the battery pack.
2. Pull the battery fastener down to unlock, tilt the battery pack up, and pull the battery pack claw out from the battery hook.
3. Remove the battery pack.
4. Attach the battery connector cap to the power cable.

WHEEL KIT (OPTIONAL)

For attaching and removing the wheel kit, place the plate compactor on secure level ground with the DC power unit off.

FROM STORING TO OPERATING POSITION

1. Pull up the knob of wheel kit stopper, then push down the wheel kit until it touches the ground (Figure 7).

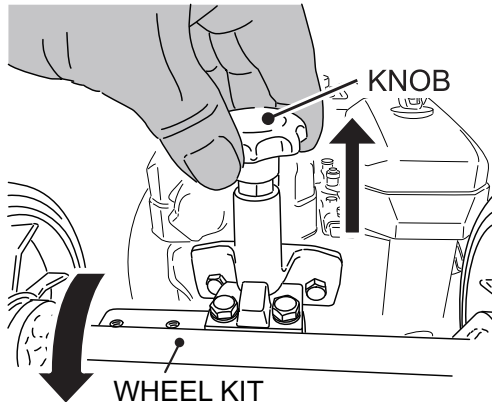

Figure 7. Wheel Kit Stopper Knob

2. Move the handle to operating position, then turn the eye nut of handle stopper, 90 degrees to the right (Figure 8).

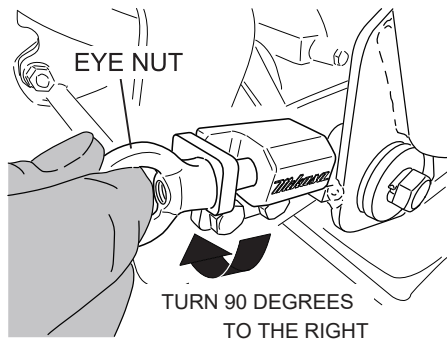

Figure 8. Handle Stopper Eye Nut

3. Push in the handle stopper (Figure 9) and secure by inserting the stopper pin (Figure 10).

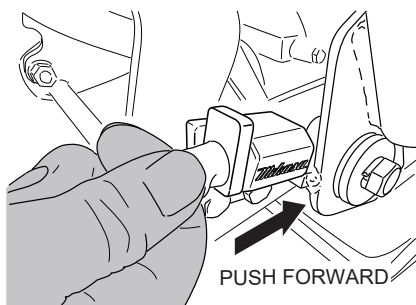

Figure 9. Handle Stopper (Push In)

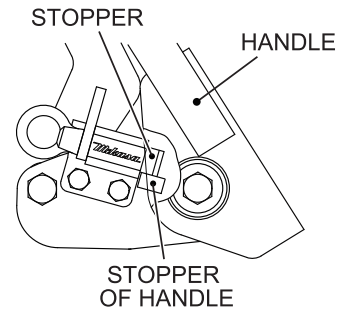

Figure 10. Handle Stopper Pin

4. Tilt the handle to the front until the rear end of vibrating plate is off the ground. Then, push the wheel kit to the underside of vibrating plate until the frame of wheel kit touches the vibrating plate (Figure 11).

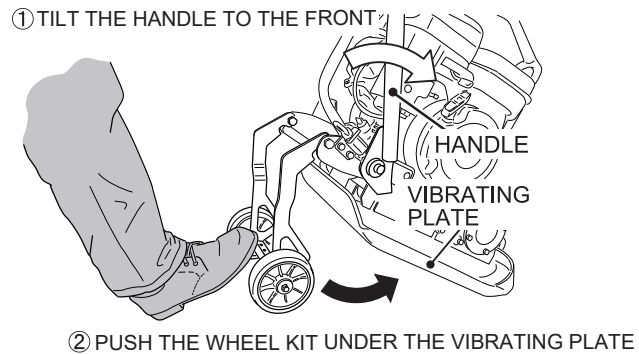

Figure 11. Operating Position

5. Pull back the handle to the rear, and lift up the vibrating plate by wheel kit. Then, move the plate compactor keeping horizontal position (Figure 12).

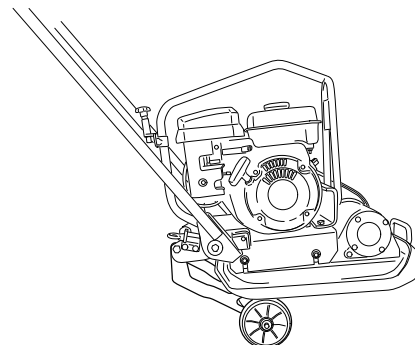

Figure 12. Moving Wheel kit

WHEEL KIT (OPTIONAL)

FROM OPERATING TO STORING POSITION

1. Position the plate compactor so that the front end of vibrating plate touches the ground. Then, tilt the handle to the front until the wheel kit leaves the ground (Figure 13).

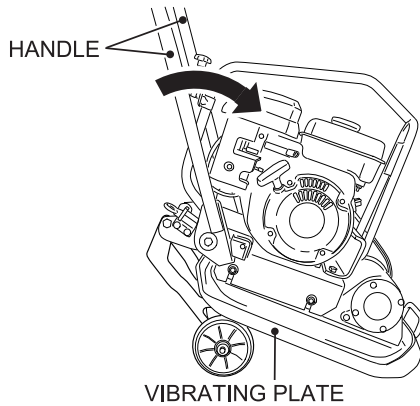

Figure 13. Tilting The Handle

2. Pull the wheel kit to the rear, then release the plate compactor to the ground (Figure 14).

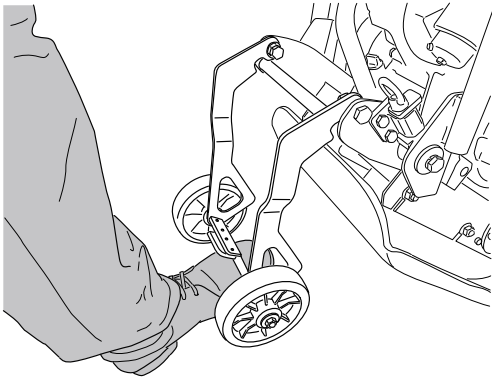

Figure 14. Pulling Wheel kit

3. Pull the wheel kit to the storing position (Figure 15).

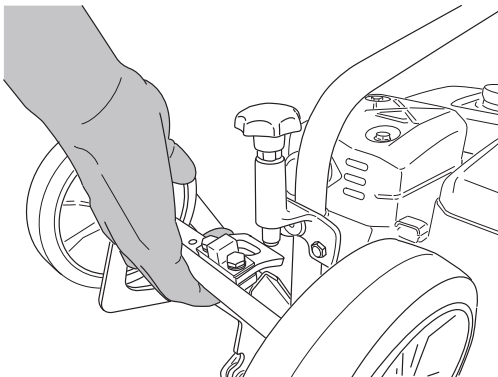

Figure 15. Storing Position

4. When the stopper rubber of wheel kit makes contact with the wheel kit stopper, the wheel kit is set at storing position by the self-locking system (Figure 16).

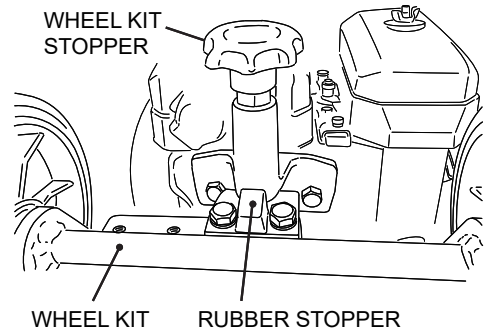

Figure 16. Self-Locking System

5. Pull the eye nut of handle stopper, then turn it to the left 90 degrees (Figure 17).

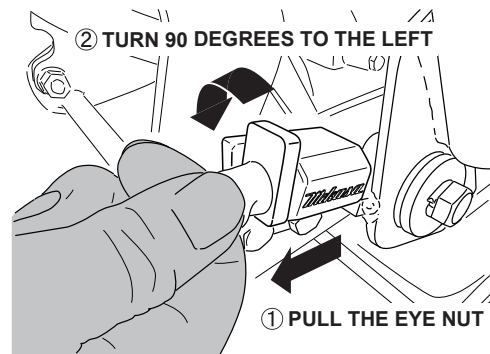

Figure 17. Handle Stopper Eye Nut

6. The storing is complete.

CAUTION

Failure to understand the operation of the plate compactor could result in severe damage to the unit or personal injury.

STARTUP

Refer to Figure 18 for location of buttons and indicators on the control panel.

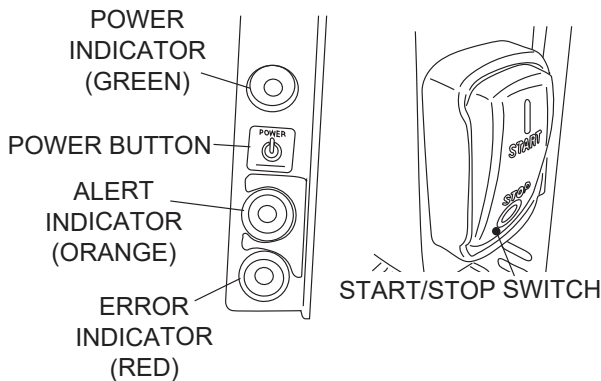

Figure 18. Switch Box

When starting the plate compactor, perform the following:

1. Press STOP on the START/STOP switch.
2. Press the POWER button.
3. All the indicators should illuminate for a few seconds, and then only the POWER indicator remains illuminated.

OPERATION

1. Hold the handle firmly.
2. Press START on the START/STOP switch to start moving forward by starting the DC Power Unit.
3. To stop, press STOP on the START/STOP switch. The DC Power Unit stops and the POWER indicator turns off.

NOTICE

- If the POWER button is pressed when the START/STOP switch is in the START position, the POWER indicator remains off and the ALERT indicator flashes. In this case, the DC Power Unit cannot start. Press STOP on the START/STOP switch then press the POWER button.
- It may take some time for the indicators to light after the POWER button is pressed. If the indicators do not light, press the POWER button again.
- If the DC Power Unit is not operated for about one minute after the POWER button is pressed, the POWER indicator turns off. Press the POWER button again to start the DC Power Unit.

CAUTION

- **DO NOT** use this machine on ground that is harder than the machine can handle, or for driving pilings or tamping rock beds.
- Furthermore, use of the machine on sloping ground, such as the side of an embankment, may make the machine unstable and can cause an accident. It can also result in premature machine wear due to uneven loads on the machine.
- Only use the machine for compacting earth and sand, soil, and asphalt.
- **DO NOT** use the machine for other types of jobs.
- In cold weather, the rammer can be warmed up by pressing START and STOP on the START/STOP switch several times until the plate compactor operates smoothly.

STOPPING THE DC POWER UNIT

1. Press STOP on the START/STOP switch
2. The DC Power Unit stops and the POWER indicator turns off.

CAUTION

You can also stop the DC Power unit by pressing the POWER button, but it may take some time to stop.

WATER TANK (OPTIONAL)

1. If your unit is equipped with the water tank and your application requires sprinkling work, open the cock of water tank(Figure 19).

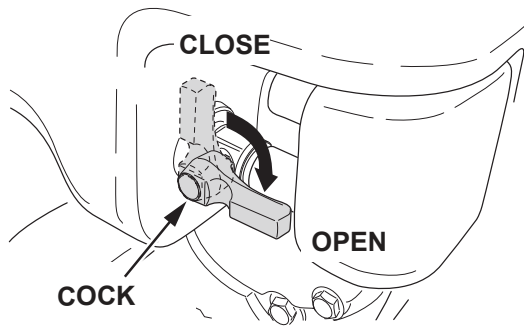

Figure 19. Water Tank Cock (Open)

2. When stopping sprinkling work, close the cock of water tank (Figure 20).

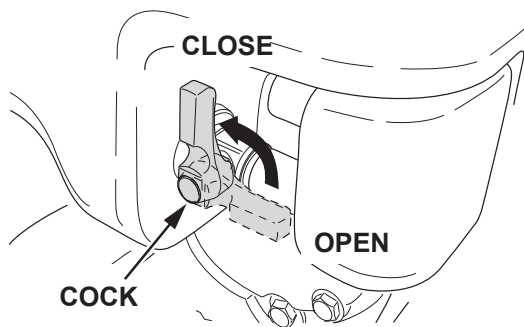

Figure 20. Water Tank Cock (Close)

CAUTION

Inspection and other services should always be carried out on hard and level ground with the engine shut down.

INSPECTION AND MAINTENANCE TABLES

To make sure your plate compactor is always in good working condition before using, carry out the maintenance inspection in accordance with Table 8.

Table 8. Machine Inspection

Item	Frequency of Inspection
Loose or Missing Screws	Every 8 hours (daily)
Damaged Parts	Every 8 hours (daily)
Function of Controlling System Part	Every 100 hours
Vibrator Oil Check	Every 8 hours (daily)
Vibrator Oil Replacement	Every 200 hours
V-belt (clutch) Check	Every 200 hours

NOTICE

These inspection intervals are for operation under normal conditions. Adjust your inspection intervals based on the number of hours the plate compactor has been in use, and the type of working conditions it is being used.

DAILY INSPECTION

1. Check for leakage of fuel or oil.
2. Check for loose screws including tightness. See Table 9 (Tightening Torque) for retightening.

Table 9. Tightening Torque (kg cm)

Material	Diameter							
	6mm	8mm	10mm	12mm	14mm	16mm	18mm	20mm
4T	70	150	300	500	750	1,100	1,400	2,000
6-8T	100	250	500	800	1,300	2,000	2,700	3,800
11T	150	400	800	1,200	2,000	2,900	4,200	5,600
*	100	300-350	650-700					

* (for aluminum counterpart)
(Threads in use with this machine are all right-handed)
Material and quality of material is marked on each bolt and screw.

3. Remove soil and clean the bottom of compaction plate.

V-BELT CHECK

CAUTION

NEVER attempt to check the V-belt with the power on. Severe injury can occur if your hand (Figure 21) gets caught between the V-belt and the clutch. Always use safety gloves.

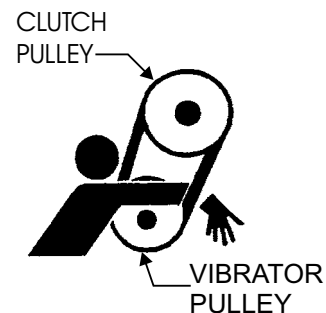

Figure 21. V-Belt Hazard

1. The V-belt tension is proper if the V-belt bends 10 to 15 mm (Figure 22) when depressed with finger midway between the clutch and vibration pulley shafts.

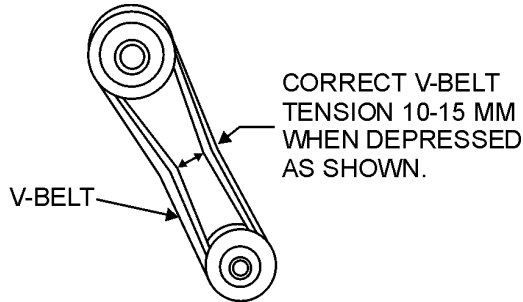

Figure 22. V-Belt Tension

2. A loose V-belt will decrease the power transmission output causing reduced compaction and premature wear of the belt.
3. If the V-belt becomes worn or loose, replace it.

Checking Clutch

Check the clutch simultaneously with V-belt checking. With belt removed, visually check outer drum of the clutch for seizure and "V" groove for wear or damage. Clean the "V" groove as necessary. Regularly check the lining or shoe for wear. If the shoe is worn, power transmission becomes deficient and slipping will result.

NOTICE

Whenever the compactor's vibration becomes weak or lost during normal operation, regardless of operation hours, check the V-belt and clutch immediately.

VIBRATOR OIL LEVEL CHECK

1. When changing the vibrator oil, remove the drain plug.
2. In every 300 hours of operation, replace oil (capacity - 0.148 quart (0.14 liter)).
 - * Use engine oil 10W-30 for this lubrication.

NOTICE

Always clean the area around the vibrator oil level check hole before removing oil check plug. This will prevent dirt and debris from entering the system.

CHECKING ENGINE BOLT

1. Check the condition of engine bolt. If the engine bolt is damaged, worn and deformed, V-belt tension becomes

low and DC power unit is damaged due to contact between the engine bolt and vibrating plate directly.

2. Replace with new one when the thickness of rubber of engine bolt mount becomes 10mm or less (Figure 23).

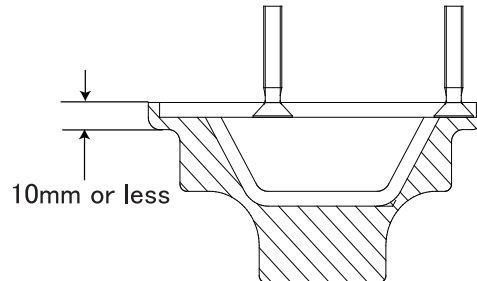

<CROSS SECTION OF ENGINE BOLT>

Figure 23. Cross-section of Engine Bolt

CHECKING THE SWITCH BOX

1. Check that the switch box assembly is not loose.
2. If switch box assembly is loose, it may get damaged or fall off.
3. To tighten, remove the switch box, then replace the grommet installed to switch box panel to new one (Figure 24).

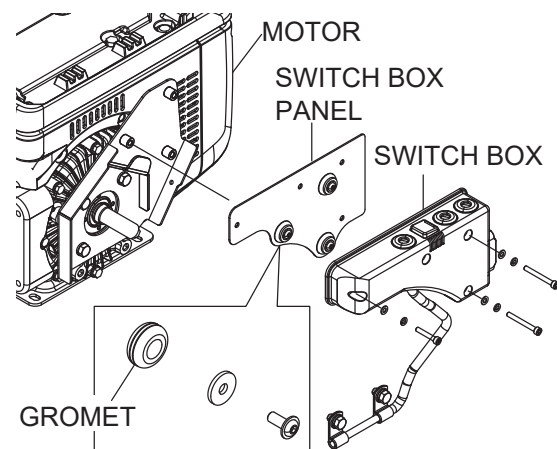

Figure 24. Checking Switch Box

PLATE COMPACTOR STORAGE

For storage of the plate compactor for over 30 days, the following is required:

1. Completely drain oil from the vibrating case.
2. Clean entire plate compactor, especially the bottom plate removing all dirt and foreign matter.
3. Cover plate compactor and engine with plastic covering or equivalent and store in a clean, dry place.

TROUBLESHOOTING

Troubleshooting (DC Power Unit)		
Symptom	Possible Problem	Solution
DC Power Unit starts normally, but forward movement is not stable or it does not vibrate.	Excessive vibrator oil?	Correct quantity of oil.
	Clutch slips?	Correct or replace.
	V-belt slips or comes off?	Correct or replace.
	Bearing failure?	Replace.
	Shock absorbers wear or cracks?	Replace.

WIRING DIAGRAM

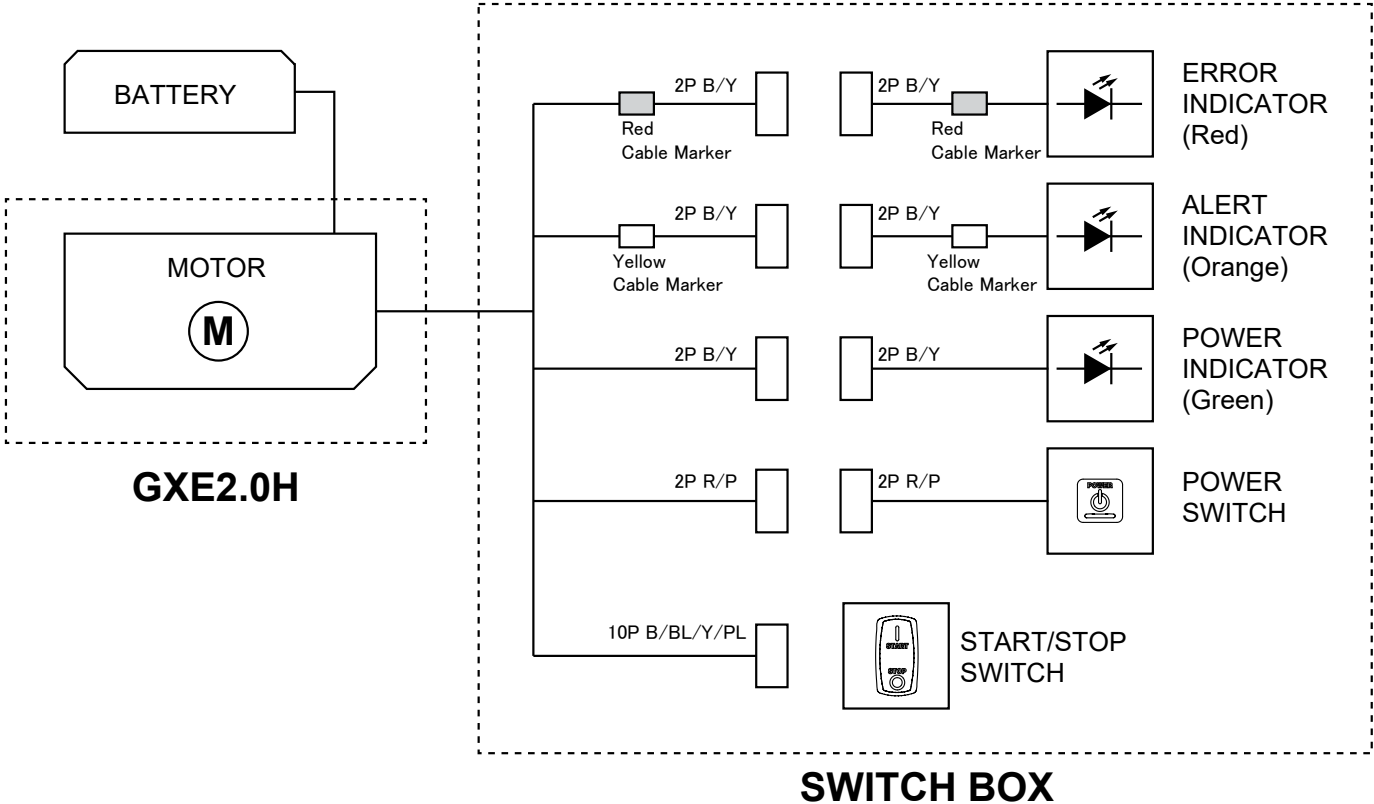

OPERATION MANUAL

HERE'S HOW TO GET HELP

PLEASE HAVE THE MODEL AND SERIAL
NUMBER ON-HAND WHEN CALLING

UNITED STATES

Multiquip Inc.

(310) 537- 3700
6141 Katella Avenue Suite 200
Cypress, CA 90630
E-MAIL: mq@multiquip.com
WEBSITE: www.multiquip.com

CANADA

Multiquip

(450) 625-2244
4110 Industriel Boul.
Laval, Quebec, Canada H7L 6V3
E-MAIL: infocanada@multiquip.com

UNITED KINGDOM

Multiquip (UK) Limited Head Office

0161 339 2223
Unit 2, Northpoint Industrial Estate,
Globe Lane,
Dukinfield, Cheshire SK16 4UJ
E-MAIL: sales@multiquip.co.uk

© COPYRIGHT 2021, MULTIQUIP INC.

Multiquip Inc, the MQ logo are registered trademarks of Multiquip Inc. and may not be used, reproduced, or altered without written permission. All other trademarks are the property of their respective owners and used with permission.

This manual MUST accompany the equipment at all times. This manual is considered a permanent part of the equipment and should remain with the unit if resold.

The information and specifications included in this publication were in effect at the time of approval for printing. Illustrations, descriptions, references and technical data contained in this manual are for guidance only and may not be considered as binding. Multiquip Inc. reserves the right to discontinue or change specifications, design or the information published in this publication at any time without notice and without incurring any obligations.

Your Local Dealer is:

