

PARTS MANUAL



Mikasa SERIES
MODEL MVH128GH
REVERSIBLE PLATE COMPACTOR
(HONDA GX160UT2SCM GASOLINE ENGINE)

Revision #1 (06/08/20)

To find the latest revision of this publication or associated operation manual, visit our website at: www.multiquip.com



THIS MANUAL MUST ACCOMPANY THE EQUIPMENT AT ALL TIMES.

TABLE OF CONTENTS

MVH128GH Reversible Plate Compactor

Explanation Of Code In Remarks Column.....	4
Suggested Spare Parts	5

Compactor Component Drawings

Vibrating Plate Assembly.....	6-7
Vibrator Assembly	8-9
Base And Engine Assembly	10-13
Electric Device Assembly	14-15
Operation Assembly	16-19
Nameplate And Decals Assembly	20-21

Honda GX160UT2SCM Engine

Cylinder Head Assembly	22-23
Cylinder Barrel Assembly	24-25
Crankcase Cover Assembly	26-27
Crankshaft Assembly.....	28-29
Piston Assembly	30-31
Camshaft Assembly.....	32-33
Recoil Starter Assembly	34-35
Fan Cover Assembly.....	36-37
Carburetor Assembly	38-39
Air Cleaner Assembly	40-41
Muffler Assembly	42-43
Fuel Tank Assembly.....	44-45
Flywheel Assembly	46-47
Ignition Coil Assembly.....	48-49
Control Assembly	50-51
Decals Assembly	52-53

NOTICE

Specifications and part numbers are subject to change without notice.

EXPLANATION OF CODE IN REMARKS COLUMN

The following section explains the different symbols and remarks used in the Parts section of this manual. Use the help numbers found on the back page of the manual if there are any questions.

NOTICE

The contents and part numbers listed in the parts section are subject to change **without notice**. Multiquip does not guarantee the availability of the parts listed.

SAMPLE PARTS LIST

NO.	PART NO.	PART NAME	QTY.	REMARKS
1	12345	BOLT	1	INCLUDES ITEMS W/%
2%		WASHER, 1/4 IN.		NOT SOLD SEPARATELY
2%	12347	WASHER, 3/8 IN. ...	1	MQ-45T ONLY
3	12348	HOSE	A/R	MAKE LOCALLY
4	12349	BEARING	1	S/N 2345B AND ABOVE

NO. Column

Unique Symbols — All items with same unique symbol (@, #, +, %, or >) in the number column belong to the same assembly or kit, which is indicated by a note in the “Remarks” column.

Duplicate Item Numbers — Duplicate numbers indicate multiple part numbers, which are in effect for the same general item, such as different size saw blade guards in use or a part that has been updated on newer versions of the same machine.

NOTICE

When ordering a part that has more than one item number listed, check the remarks column for help in determining the proper part to order.

PART NO. Column

Numbers Used — Part numbers can be indicated by a number, a blank entry, or TBD.

TBD (To Be Determined) is generally used to show a part that has not been assigned a formal part number at the time of publication.

A blank entry generally indicates that the item is not sold separately or is not sold by Multiquip. Other entries will be clarified in the “Remarks” Column.

QTY. Column

Numbers Used — Item quantity can be indicated by a number, a blank entry, or A/R.

A/R (As Required) is generally used for hoses or other parts that are sold in bulk and cut to length.

A blank entry generally indicates that the item is not sold separately. Other entries will be clarified in the “Remarks” Column.

REMARKS Column

Some of the most common notes found in the “Remarks” Column are listed below. Other additional notes needed to describe the item can also be shown.

Assembly/Kit — All items on the parts list with the same unique symbol will be included when this item is purchased.

Indicated by:

“INCLUDES ITEMS W/(unique symbol)”

Serial Number Break — Used to list an effective serial number range where a particular part is used.

Indicated by:

“S/N XXXXX AND BELOW”

“S/N XXXX AND ABOVE”

“S/N XXXX TO S/N XXX”

Specific Model Number Use — Indicates that the part is used only with the specific model number or model number variant listed. It can also be used to show a part is NOT used on a specific model or model number variant.

Indicated by:

“XXXXX ONLY”

“NOT USED ON XXXX”

“Make/Obtain Locally” — Indicates that the part can be purchased at any hardware shop or made out of available items. Examples include battery cables, shims, and certain washers and nuts.

“Not Sold Separately” — Indicates that an item cannot be purchased as a separate item and is either part of an assembly/kit that can be purchased, or is not available for sale through Multiquip.

SUGGESTED SPARE PARTS

MVH128GH REVERSIBLE PLATE COMPACTOR

1 to 3 units

Qty.	P/N	Description
4.....	472471010.....	SHOCK ABSORBER
2.....	070100332.....	V-BELT
1.....	956100078.....	THROTTLE WIRE

NOTICE

Part numbers on this Suggested Spare Parts list may supersede/replace the part numbers shown in the following parts lists.

HONDA GX160UT2SCM GASOLINE ENGINE

1 to 3 units

Qty.	P/N	Description
3.....	0650140480.....	SPARK PLUG, (BPR6ES)
1.....	28462ZH8003.....	ROPE, RECOIL STARTER
3.....	17210Z0V781.....	ELEMENT
3.....	17218Z0V780.....	FILTER, OUTER
1.....	17620Z4H900.....	CAP COMPLETE, FUEL TANK
1.....	17672Z4H000.....	FUEL FILTER, FUEL TANK

VIBRATING PLATE ASSY.

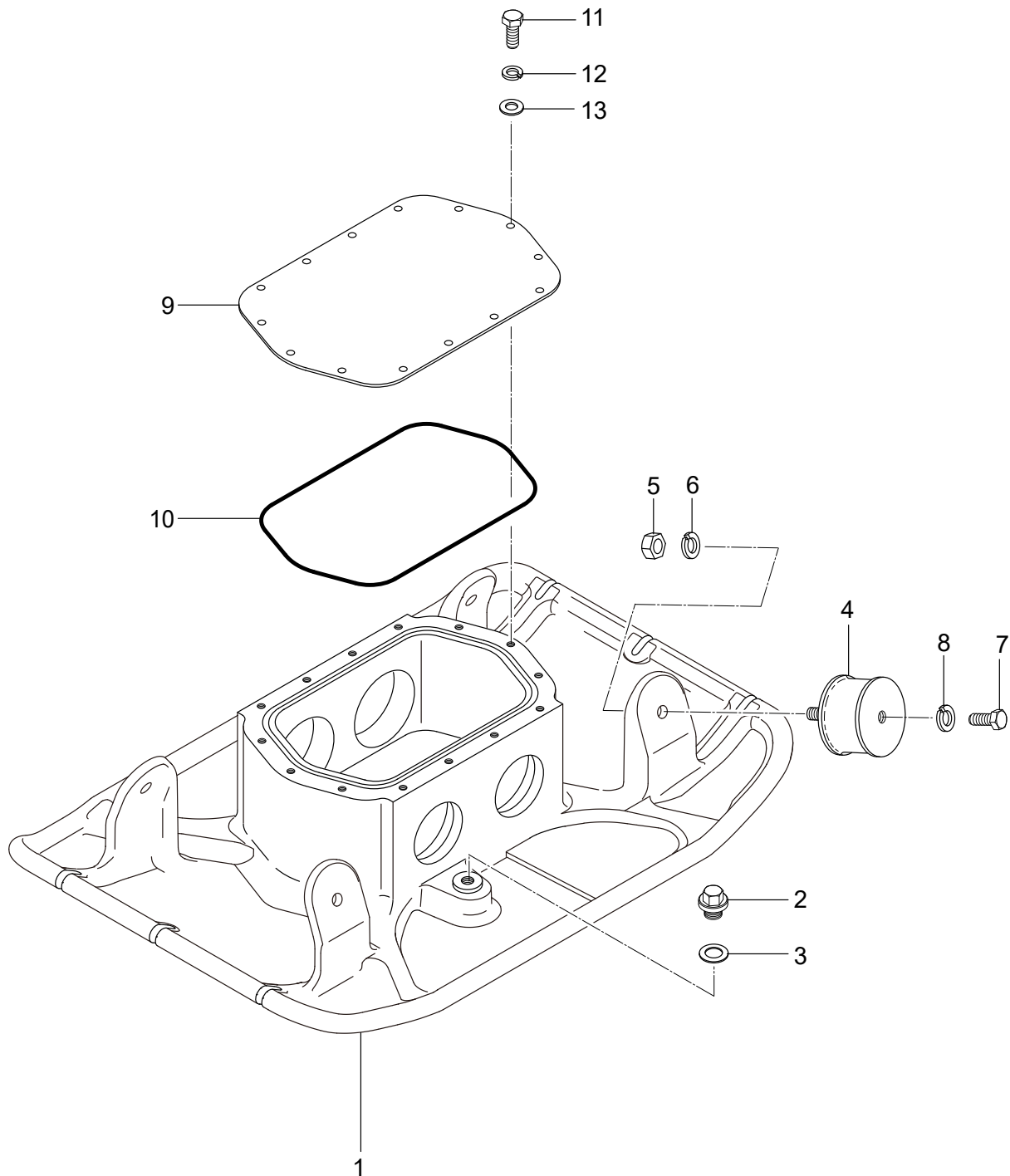

VIBRATING PLATE ASSY.

<u>NO.</u>	<u>PART NO.</u>	<u>PART NAME</u>	<u>QTY.</u>	<u>REMARKS</u>
1	472122280	VIBRATING PLATE	1	
2	953405270	PLUG	1	
3	953405260	PACKING 1/4"	1	
4	472471010	SHOCK ABSORBER	4	
5	020312100	NUT, M12	4	
6	030212300	WASHER, LOCK M12	4	
7	001221230	BOLT, 12X30	4	
8	030212300	WASHER, LOCK M12	4	
9	471354550	COVER, VIBRATOR	1	
10	050710080	O-RING	1	REPLACES P/N 050710160
11	001220820	BOLT, 8X20	14	
12	030208200	WASHER, LOCK M8	14	
13	031108160	WASHER, FLAT M8	14	

VIBRATOR ASSY.

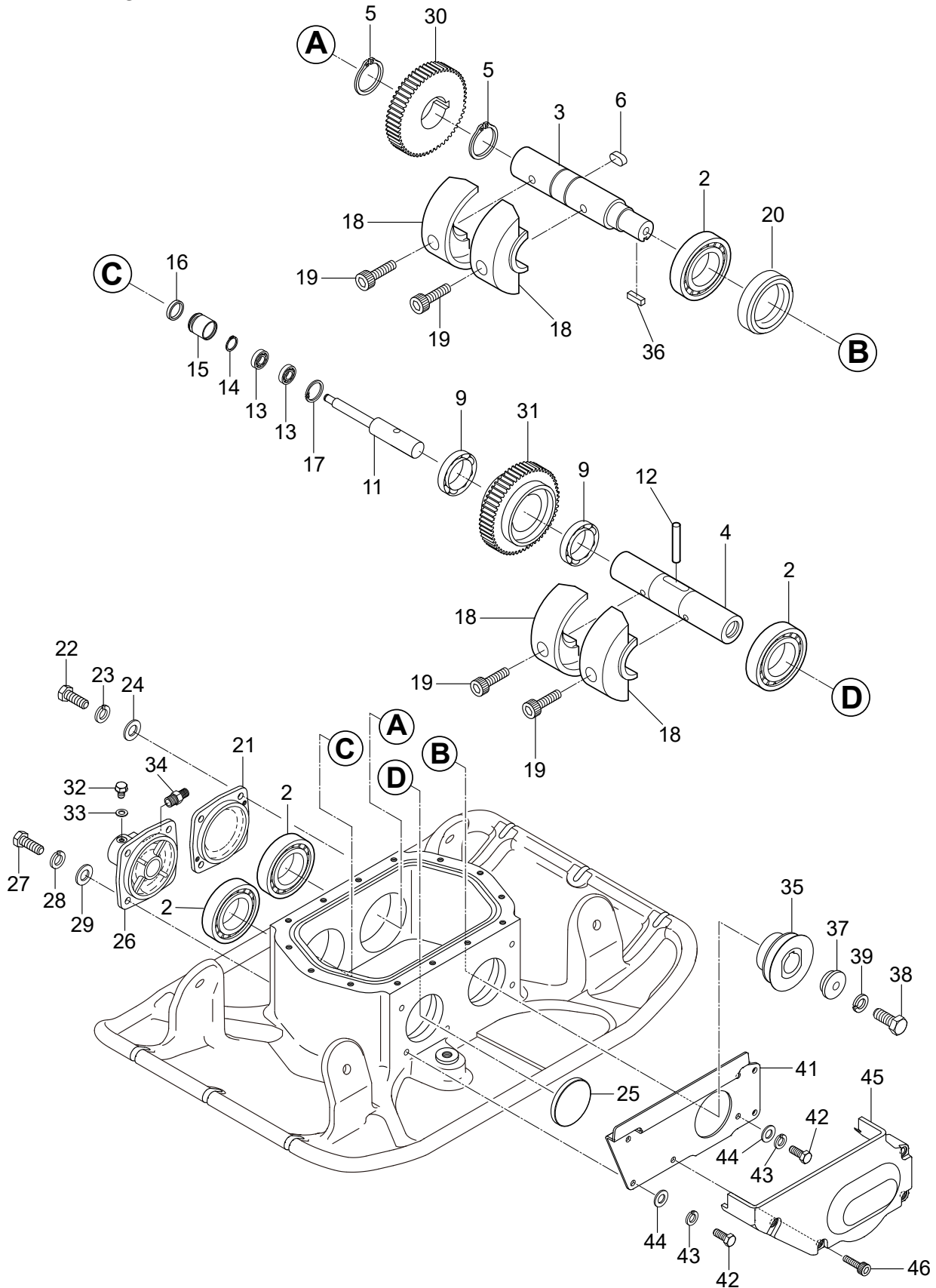

VIBRATOR ASSY.

<u>NO.</u>	<u>PART NO.</u>	<u>PART NAME</u>	<u>QTY.</u>	<u>REMARKS</u>
2	040306307	BEARING.....	4.....	REPLACES P/N 040406307
3	472355260	ROTARY SHAFT, DRIVE	1	
4	472355270	ROTARY SHAFT, DRIVEN	1	
5	080200350	STOP RING	2	
6	951405460	KEY, 10X8X19	1	
9	040306907	BEARING	2	
11	459346230	PISTON ROD	1	
12	025508050	PIN	1	
13	042006000	BEARING.....	2.....	REPLACES P/N 042506000
14	0080000010	STOP RING	1.....	REPLACES P/N 080200100
15	455435051	PISTON	1	
16	455010070	COPPER PACKING	1	
17	080100260	STOP RING	1	
18	472471020	ECCENTRIC ROTATOR	4	
19	009120306	SOCKET HEAD BOLT, 10X30	4	
20	060202060	OIL SEAL	1	
21	471354540	BEARING COVER	1	
22	001220825	BOLT, 8X25	4	
23	030208200	WASHER, LOCK M8	4	
24	031108160	WASHER, FLAT M8	4	
25	953010060	SEAL CAP	1	
26	471219700	CYLINDER	1	
27	001220825	BOLT, 8X25	4	
28	030208200	WASHER, LOCK M8	4	
29	031108160	WASHER, FLAT M8	4	
30	471354810	GEAR, DRIVE	1	
31	458342590	GEAR, DRIVEN	1	
32	001220812	BOLT, 8X12	1	
33	953404600	COPPER PACKING	1	
34	954010020	CONNECTOR, 1/4"	1	
35	472355210	PULLEY	1	
36	951400990	KEY, 7X7X20	1	
37	471470140	WASHER, PULLEY	1	
38	001220830	BOLT, 8X30	1	
39	030208200	WASHER, LOCK M8	1	
41	472355220	GUIDE, BELT COVER	1	
42	001220820	BOLT, 8X20	3	
43	030208200	WASHER, LOCK M8	3	
44	031108160	WASHER, FLAT M8	3	
45	472219870	BELT COVER, LOWER	1	
46	001520851	SOCKET HEAD BOLT, 8X55	4	

BASE AND ENGINE ASSY.

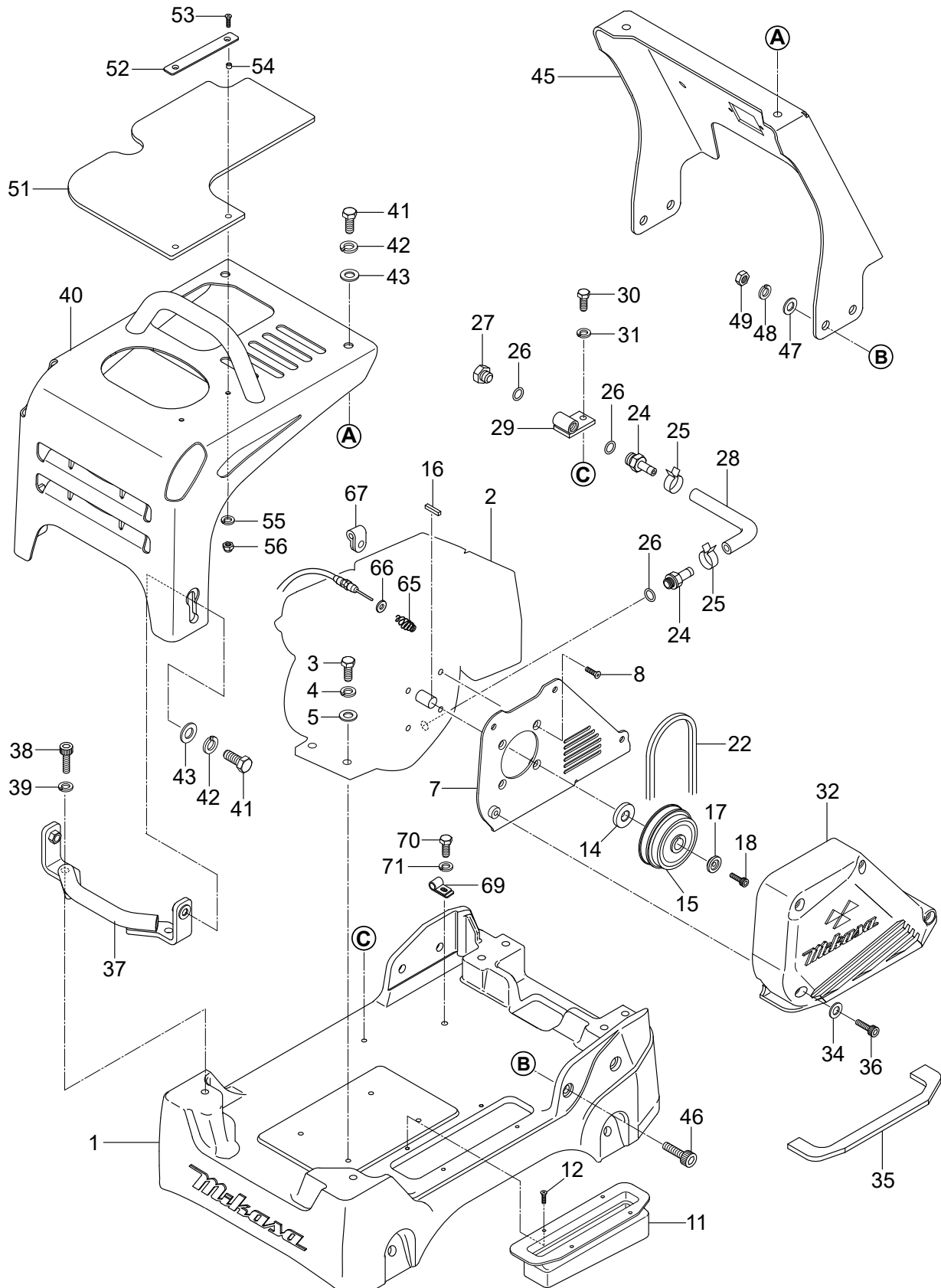

BASE AND ENGINE ASSY.

<u>NO.</u>	<u>PART NO.</u>	<u>PART NAME</u>	<u>QTY.</u>	<u>REMARKS</u>
1	472122290	BASE	1	
2	912216023	ENGINE, GX160UT2SCM	1	
3	001220840	BOLT, 8X40	4	
4	030208200	WASHER, LOCK M8	4	
5	031108160	WASHER, FLAT M8	4	
7	472355250	BELT COVER, (IN)	1	
8	009120408	SUNK HEAD BOLT, 8X20	4	
11	472219850	DUST COVER	1	
12	092006010	FLAT HEAD SCREW, 6X10	4	
14	472471230	CLUTCH, SPACER	1	
15	458337770	CLUTCH ASSY.	1	
16	0320050150	KEY	1	
17	471470090	CLUTCH, WASHER	1	
18	001520825	SOCKET HEAD BOLT, 8X25	1	
22	070100332	V-BELT	1	
24	15550ZK8P90	DRAIN JOINT	2	
25	954010070	HOSE BAND	2	
26	90601ZE1000	WASHER, DRAIN PLUG	3	
27	90131ZE1000	BOLT, DRAIN PLUG	1	
28	15552ZB9000	DRAIN HOSE	1	
29	459462050	JOINT	1	
30	001220820	BOLT, 8X20	1	
31	030208200	WASHER, LOCK M8	1	
32	472122390	BELT COVER (OUT)		
34	033910220	WASHER, 8.4X15.5X1.6	4	
35	472355230	DUST SPONGE (OUT)	1	
36	001520552	SOCKET HEAD BOLT, 8X60	4	
37	472355240	FRONT BUMPER	1	
38	001521235	SOCKET HEAD BOLT, 12X35	2	
39	030212300	WASHER, LOCK M12	2	
40	472122400	FRONT COVER	1	
41	001221235	BOLT, 12X35	4	
42	030212300	WASHER, LOCK M12	4	
43	031112230	WASHER, FLAT M12	4	
45	472219860	CENTER COVER	1	
46	001521030	SOCKET HEAD BOLT, 10X30	4	
47	031110160	WASHER, FLAT M10	4	
48	030210250	WASHER, LOCK M10	4	
49	020310080	NUT M10	4	

BASE AND ENGINE ASSY. CONT'D.

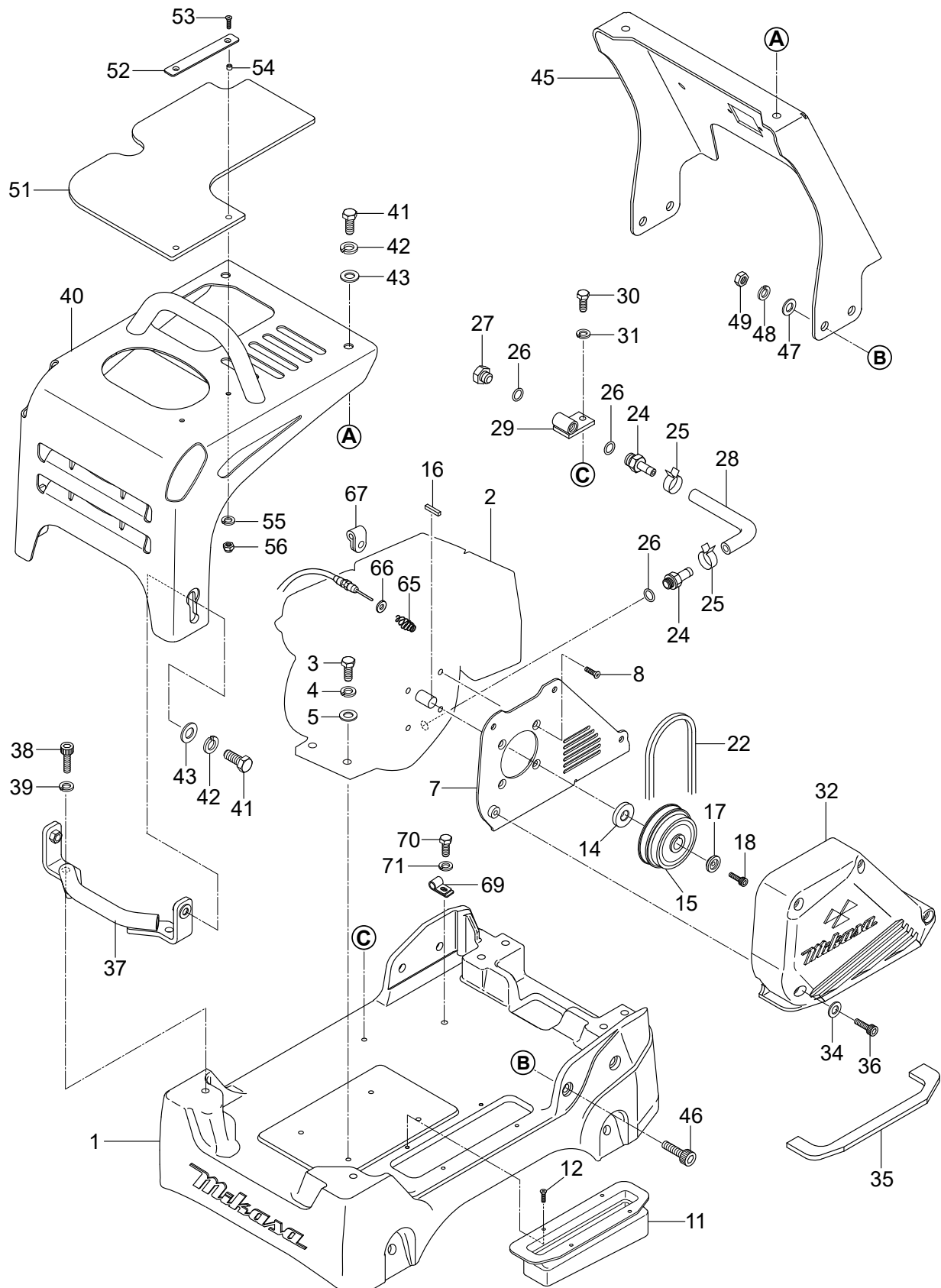

BASE AND ENGINE ASSY. CONT'D.

<u>NO.</u>	<u>PART NO.</u>	<u>PART NAME</u>	<u>QTY.</u>	<u>REMARKS</u>
51	472471040	RUBBER COVER, UPPER	1	
52	472471050	STOPPER, COVER	1	
53	009120424	SOCKET HEAD BOLT, 6X25	2	
54	617465130	COLLAR	2	
55	030206150	WASHER, LOCK M6	2	
56	022710607	NYLON NUT M6	2	
65	371467760	RETURN SPRING	1	
66	031105080	WASHER, FLAT M5	1	
67	2067550101	CLAMP, COMPLETE	1	
69	959407260	CLIP D6	1	
70	001221015	BOLT, 10X15	1	
71	030210250	WASHER, LOCK M10	1	

ELECTRIC DEVICE ASSY.

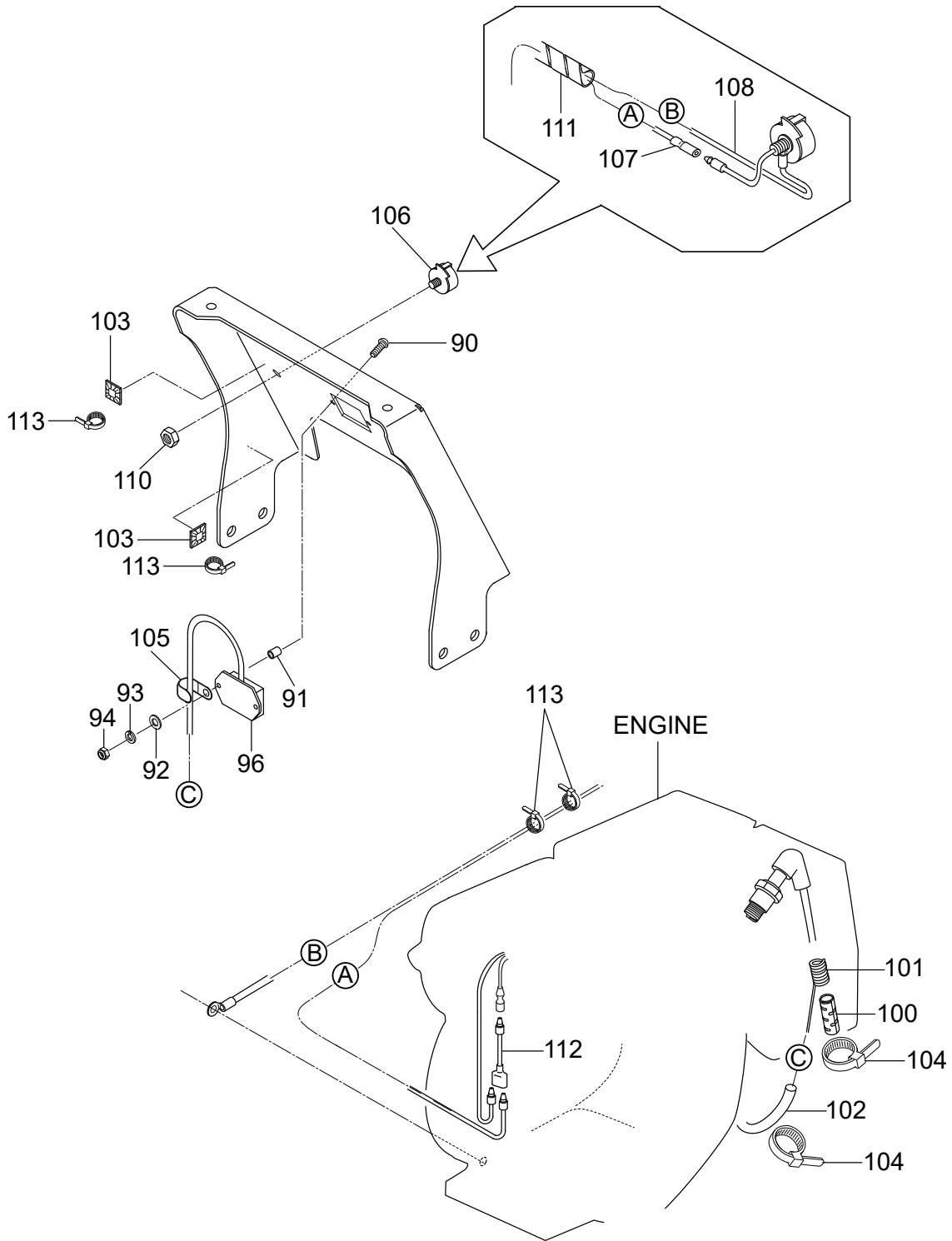

ELECTRIC DEVICE ASSY.

<u>NO.</u>	<u>PART NO.</u>	<u>PART NAME</u>	<u>QTY.</u>	<u>REMARKS</u>
90	009110072	PAN HEAD SCREW, 5X35	2	
91	952407930	COLLAR	2	
92	031105080	WASHER, FLAT M5	2	
93	030205130	WASHER, LOCK M5	2	
94	022710506	NYLON NUT M5	2	
96	955010311	TACHO/HOUR METER	1	
100	955010307	CLIP BELT	1	
101	955010317	CURL CORD	1	
102	959026836	RUBBER TUBE	1	
103	955407970	WIRING FIXED BASE	2	
104	506010070	CLAMP	2	
105	2067550101	CLAMP COMPLETE	1	
106	955301010	STOP SWITCH, ENGINE	1	
107	468467570	READ CORD	1	
108	467466980	LEAD WIRE (SW-GROUND)	1	
110	020308060	NUT M8	1	
111	959021827	SPIRAL TUBE	1	
112	515450380	WIRE HARNESS	1	
113	506010070	CLAMP	4	

OPERATION ASSY.

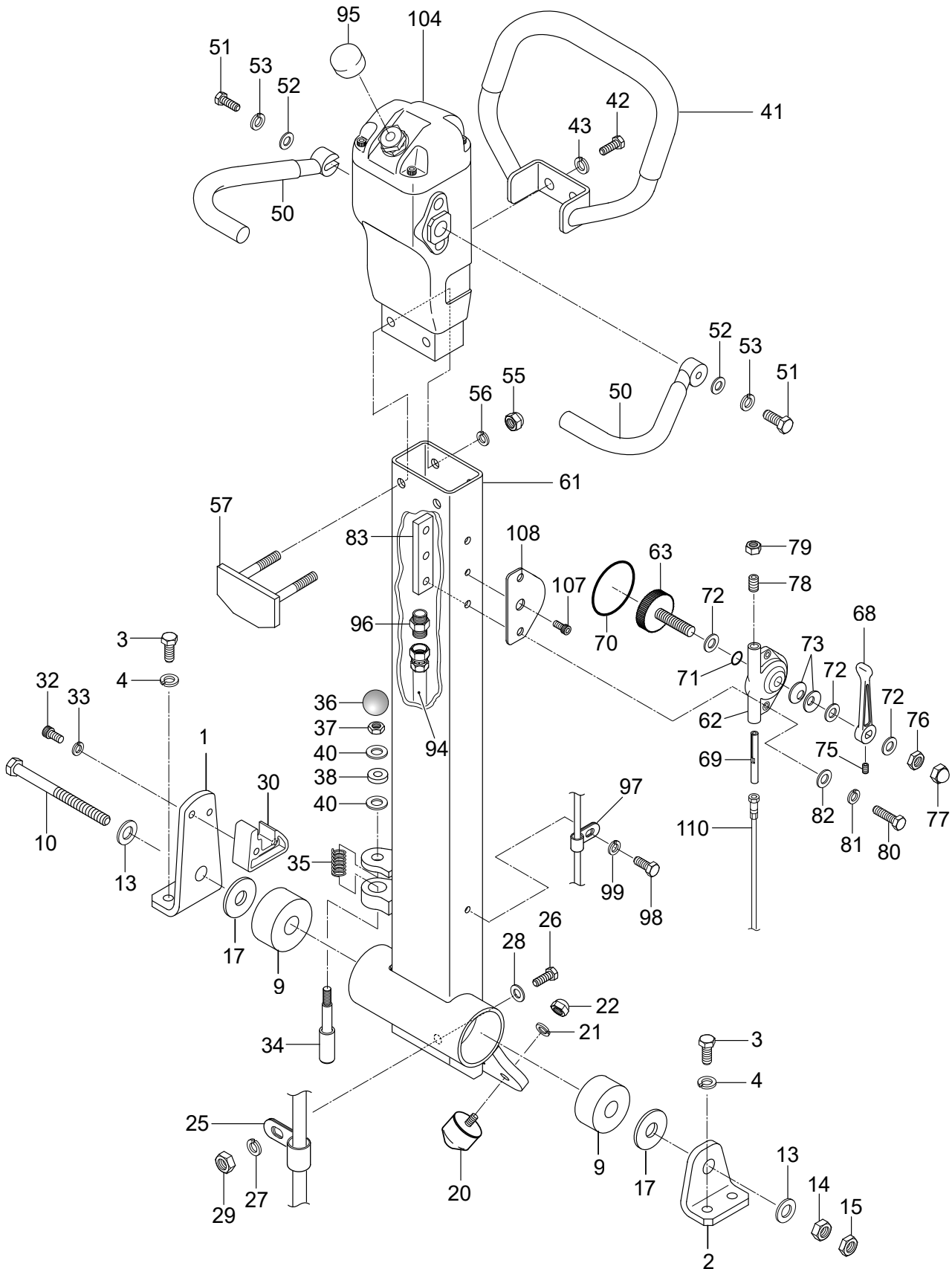

OPERATION ASSY.

<u>NO.</u>	<u>PART NO.</u>	<u>PART NAME</u>	<u>QTY.</u>	<u>REMARKS</u>
1	471354640	HANDLE BRACKET (R)	1	
2	459338030	HANDLE BRACKET (L)	1	
3	001221230	BOLT, 12X30	4	
4	030212300	WASHER, LOCK M12	4	
9	470468900	CUSHION RUBBER	2	
10	001221680	BOLT, 16X200	1	
13	031116260	WASHER, FLAT M16	2	
14	020316130	NUT M16	1	
15	020416100	NUT M16	1	
17	952409690	WASHER 17X45X4.5	2	
20	939010490	STOPPER RUBBER	2	
21	030208200	WASHER, LOCK M8	2	
22	022130806	CAP NUT M8	2	
25	959408930	CLIP 15 (M6)	1	
26	001220625	BOLT, 6X25	1	
27	030206150	WASHER, LOCK M6	1	
28	031106100	WASHER, FLAT M6	1	
29	020306050	NUT M6	1	
30	471354710	HANDLE ROCK STOPPER	1	
32	001520825	SOCKET HEAD BOLT 8X25	2	
33	030208200	WASHER, LOCK M8	2	
34	471470170	STOPPER, HANDLE	1	
35	471470180	SPRING, STOPPER	1	
36	959409700	BALL GRIP	1	
37	020410060	NUT M10	1	
38	456449980	RUBBER PACKING	1	
40	031110160	WASHER, FLAT M10	2	
41	458214400	HANDLE GRIP	1	
42	001220820	BOLT, 8X20	2	
43	030208200	WASHER, LOCK M8	2	
50	471354800	LEVER, TRAVEL	2	
52	001220830	BOLT, 8X30	2	
53	031108160	WASHER, FLAT M8	2	
54	030208200	WASHER, LOCK M8	2	
55	022710809	NYLON NUT M8	2	
56	030208200	WASHER, LOCK M8	2	
57	458337480	PUMP HOLDER	1	

OPERATION ASSY. CONT'D.

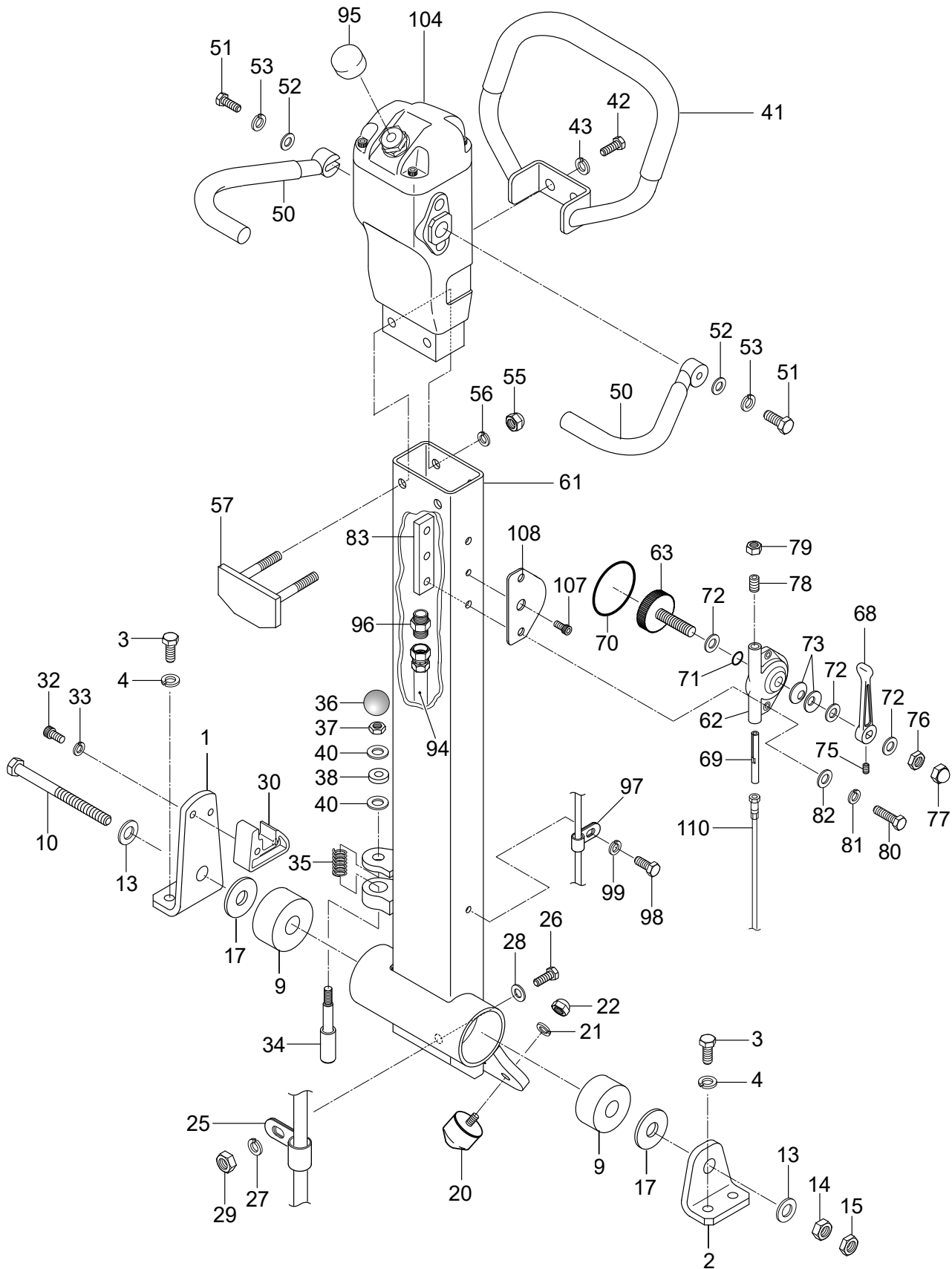

OPERATION ASSY. CONT'D.

<u>NO.</u>	<u>PART NO.</u>	<u>PART NAME</u>	<u>QTY.</u>	<u>REMARKS</u>
61	471122170	HANDLE BAR	1	
62	362341550	THROTTLE BODY	1	
63	362456521	THROTTLE GEAR	1	
68	362455630	THROTTLE LEVER	1	
69	362455620	SLIDER	1	
70	050100450	O-RING	1	
71	050200100	O-RING	1	
72	031110160	WASHER, FLAT M10	3	
73	032110180	CONICAL SPRING WASHER M10	2	
75	096206006	SOCKET HEAD SCREW 6X6	1	
76	020410060	NUT, M10	1	
77	022131008	CAP, NUT M10	1	
78	096208020	SOCKET HEAD SCREW 8X20	1	
79	020408050	NUT, M8	1	
80	001220625	BOLT 6X25	2	
81	030206150	WASHER, LOCK M6	2	
82	031106100	WASHER, FLAT M6	2	
83	463455960	THROTTLE NUT	1	
94	459452060	OIL HOSE	1	
95	458451630	BREATHER CAP	1	
96	954003150	MALE CONNECTOR, O-RING 1/4"	1	
97	2067550101	CLAMP COMPLETE	1	
98	001220615	BOLT 6X15	1	
99	030206150	WASHER, LOCK M6	1	
104	459219610	HAND PUMP	1	
107	001520510	SOCKET HEAD BOLT 5X10	1	
108	463455950	SPACER, THROTTLE	1	
110	956100078	THROTTLE WIRE	1	

NAMEPLATE AND DECALS ASSY.

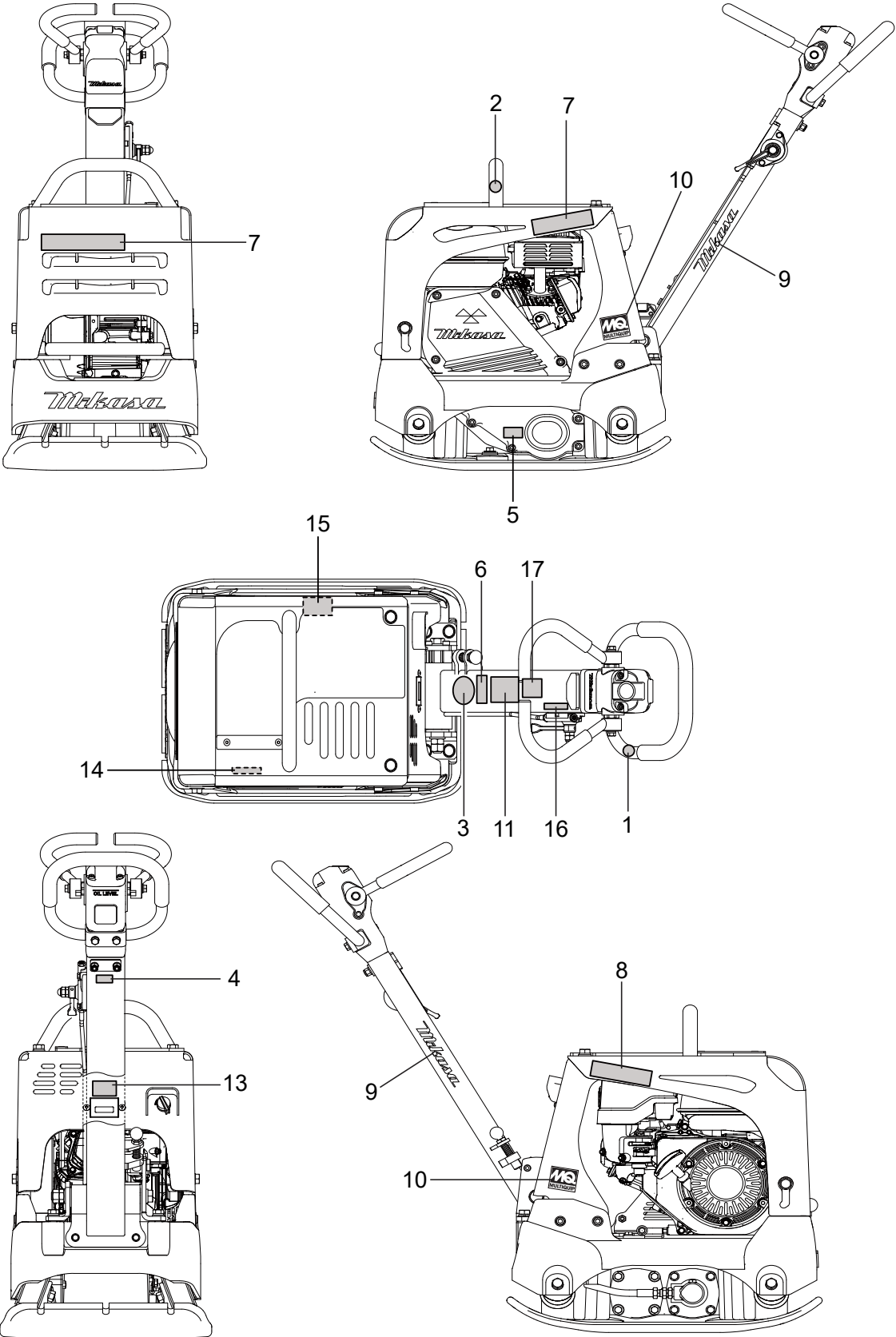

NAMEPLATE AND DECALS ASSY.

<u>NO.</u>	<u>PART NO.</u>	<u>PART NAME</u>	<u>QTY.</u>	<u>REMARKS</u>
1	920900090	DECAL, DO NOT LIFT	1.....	REPLACES P/N 920214730
2	920214740	DECAL, LIFTING POSITION	1	
3	920203330	EAR PROTECTION LABEL	1	
4	920211090	DECAL, SHELL TELLUS OIL 32	1	
5	920201950	DECAL, OIL SAE 10W-30	1	
6	920214100	DECAL, E/G FIRE WARNING	1	
7	920221730	DECAL, MODEL (R, OR)	2	
8	920221740	DECAL, MODEL (L, OR)	1	
9	920217130	DECAL, MIKASA MARK	2	
10	920220220	DECAL, MQ MARK	2	
11	920218390	DECAL, CAUTION	1	
13	920218130	DECAL, E/G RPM 3600	1	
14	920208350	DECAL, V-BELT RPF3330	1	
15	920221750	PLATE, SERIAL NO./MQ	1	
16	920211690	DECAL, LEVER OPERATION	1	
17	920220810	DECAL, CAUTION, LEVER	1	

HONDA GX160UT2SCM ENG. — CYLINDER HEAD ASSY.

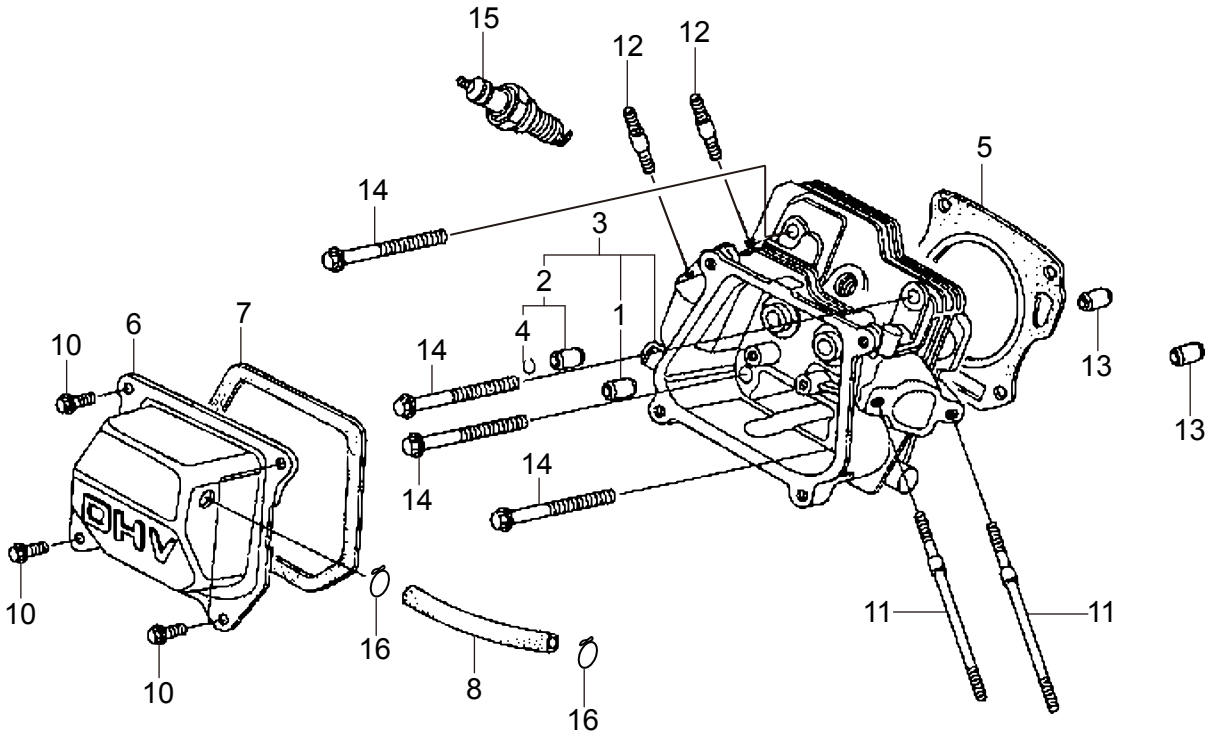

HONDA GX160UT2SCM ENG. — CYLINDER HEAD ASSY.

<u>NO.</u>	<u>PART NO.</u>	<u>PART NAME</u>	<u>QTY.</u>	<u>REMARKS</u>
1%	12204ZE1306	GUIDE, INLET VALVE (O.S.)	1	
2%	12205ZE1315	GUIDE, EXHAUST VALVE (O. S.).....	1.....	INCLUDES ITEM W/\$
3	12210Z4M405	HEAD COMPLETE, CYLINDER.....	1.....	INCLUDES ITEMS W/%
4\$%	12216ZE5300	CLIP, VALVE GUIDE	1	
5	12251ZL0003	GASKET, CYLINDER HEAD	1	
6	12310Z4M840	COVER COMPLETE, HEAD	1	
7	12391ZE1000	PACKING, HEAD COVER	1	
8	15721ZE1840	TUBE, BREATHER	1	
10	90013883000	FLANGE BOLT 6X12	4	
11	90043ZE1020	STUD BOLT 6X112	2	
12	90047ZE1000	STUD BOLT 8X32	2	
13	9430110160	KNOCK PIN 10X16	2	
14	957010806000	BOLT, FLANGE 8X60	4	
15	0650140480	SPARK PLUG, BPR6ES	1	
16	9500280000	CLIP, TUBE	2	

HONDA GX160UT2SCM ENG. — CYLINDER BARREL ASSY.

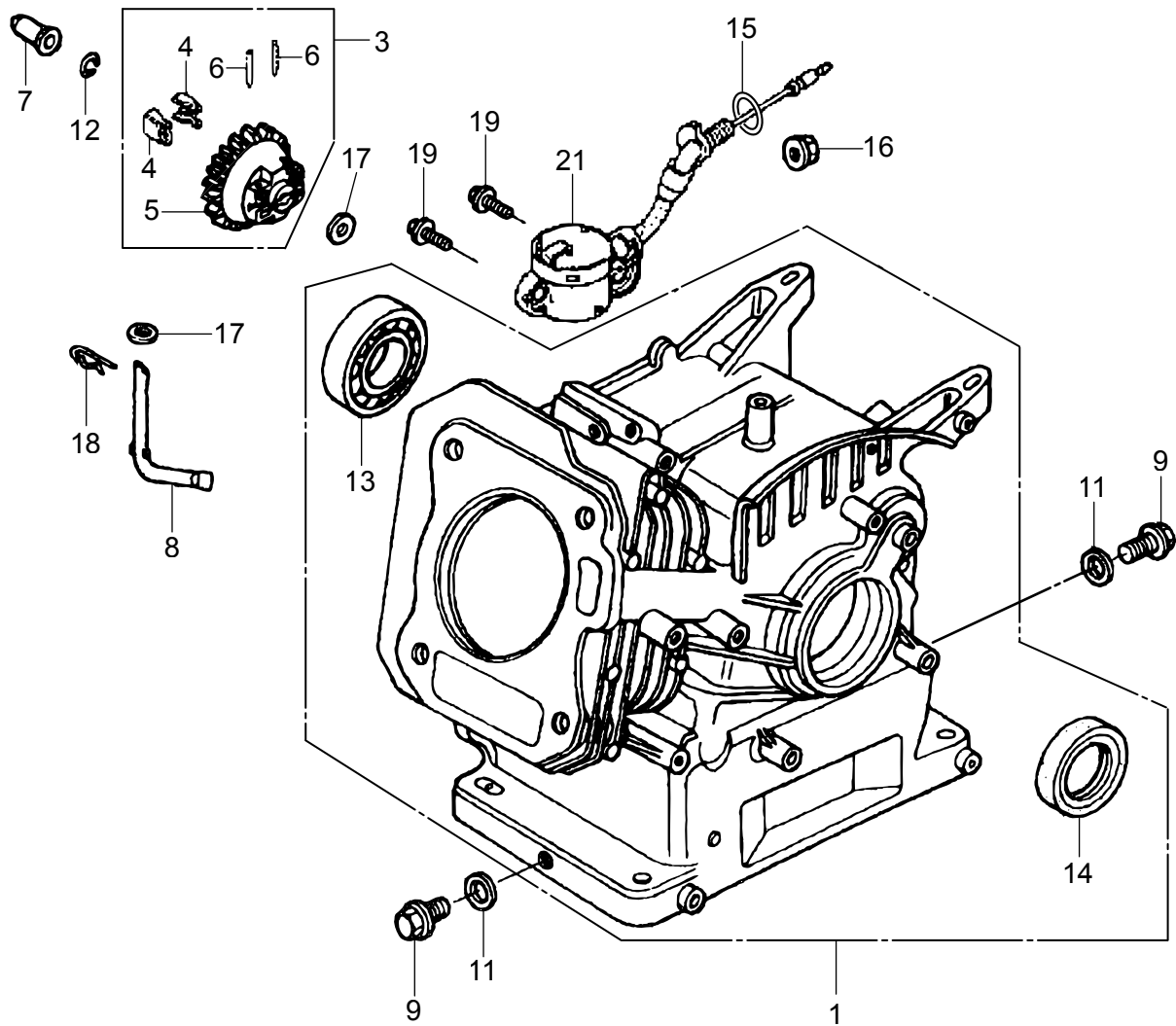

HONDA GX160UT2SCM ENG. — CYLINDER BARREL ASSY.

NO.	PART NO.	PART NAME	QTY.	REMARKS
1	12000Z4M416	BARREL, ASSY. CYLINDER (OIL ALERT).....	1.....	INCLUDES ITEMS W/\$
3	16510Z4M000	GOVERNOR ASSY.....	1.....	INCLUDES ITEMS W/%
4%	16511Z4M000	WEIGHT, GOVERNOR	2	
5%	16512Z4M000	HOLDER, GOVERNOR WEIGHT	1	
6%	16513ZE1000	PIN, GOVERNOR WEIGHT	2	
7	16531Z4M000	SLIDER, GOVERNOR	1	
8	16541Z4M000	SHAFT, GOVERNOR ARM	1	
9	90131ZE1000	BOLT, DRAIN PLUG	2	
11	90601ZE1000	WASHER, DRAIN PLUG	2	
12	90602ZE1000	CLIP, GOVERNOR HOLDER	1	
13\$	91001ZF1003	BALL BEARING	1	
14\$	91201Z0T801	OIL SEAL 25X41X6	1	
15	91353671003	O-RING 14MM.....	1.....	REPLACES P/N 91353671004
16	9405010000	FLANGE NUT M10	1	
17	9410106800	WASHER, FLAT 6MM	2	
18	9425108000	LOCK PIN 8MM	1	
19	957010601200	FLANGE BOLT 6X12	2	
21	35480Z0T003	SWITCH ASSY., OIL LEVEL	1	

HONDA GX160UT2SCM ENG. — CRANKCASE COVER ASSY.

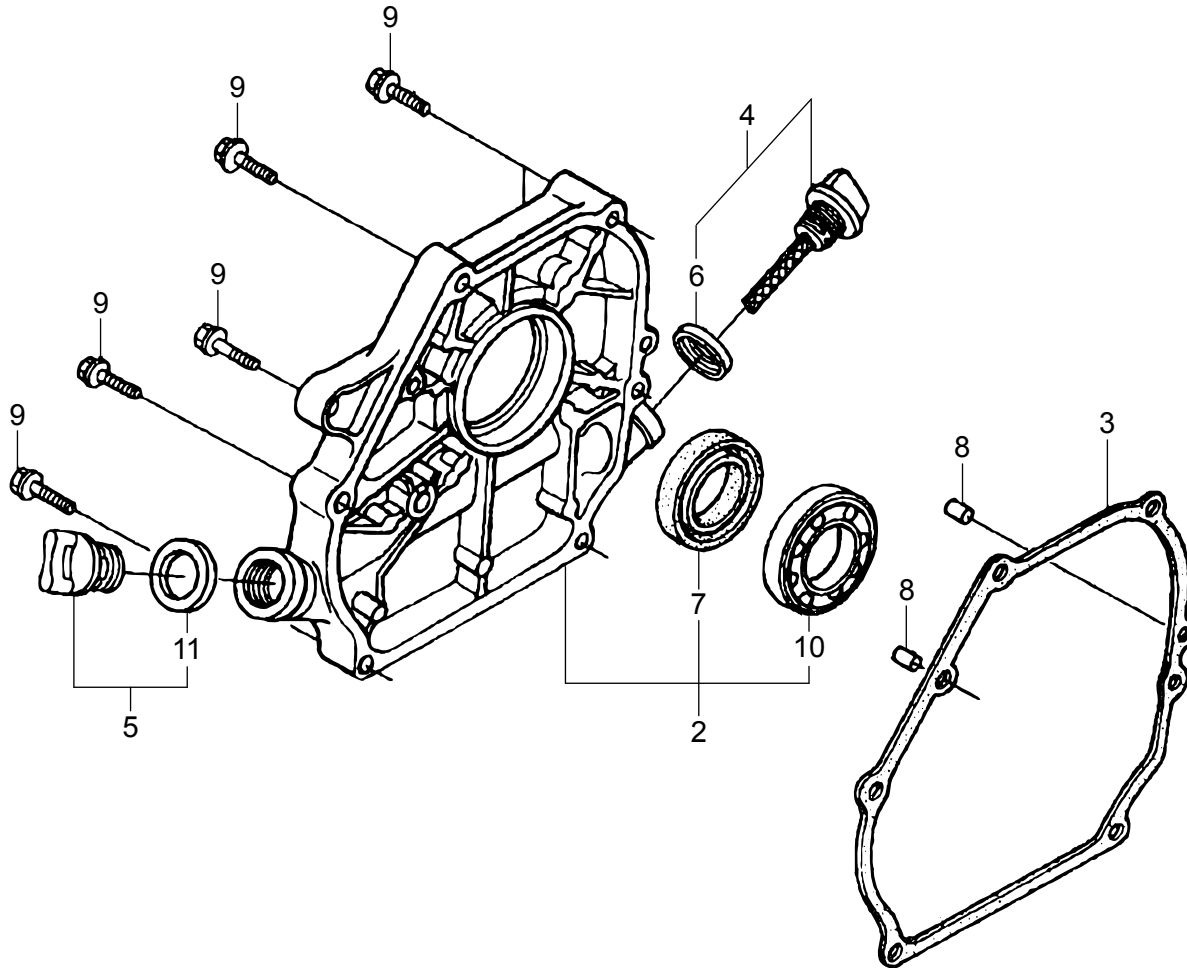

HONDA GX160UT2SCM ENG. — CRANKCASE COVER ASSY.

<u>NO.</u>	<u>PART NO.</u>	<u>PART NAME</u>	<u>QTY.</u>	<u>REMARKS</u>
2	11300Z4M630	COVER, ASSY., CRANKCASE.....	1.....	INCLUDES ITEMS W/#
3	11381ZH8801	GASKET, CRANKCASE	1	
4	15600Z0T810	CAP ASSY., OIL FILLER	1.....	INCLUDES ITEMS W/\$
5	15600Z0T820	CAP ASSY., OIL FILLER	1.....	INCLUDES ITEMS W/%
6\$	15625Z0T800	PACKING, OIL FILLER CAP	1	
7#	91201Z0T801	OIL SEAL 25X41X6	1	
8	9430108140	KNOCK PIN 8X14	2	
9	957010803200	FLANGE BOLT 8X32	6	
10#	961006205010	BALL BEARING.....	1.....	REPLACES P/N 961006205000
11%	15625Z0T800	PACKING, OIL FILLER CAP	1	

HONDA GX160UT2SCM ENG. — CRANKSHAFT ASSY.

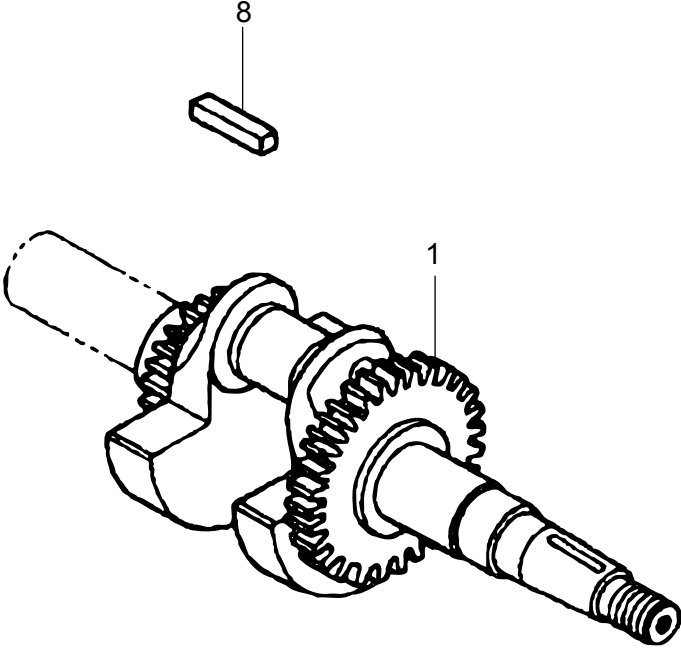

HONDA GX160UT2SCM ENG. — CRANKSHAFT ASSY.

<u>NO.</u>	<u>PART NO.</u>	<u>PART NAME</u>	<u>QTY.</u>	<u>REMARKS</u>
1	13310Z4M880	CRANKSHAFT COMPLETE	1	
8	90741883810	KEY 5X5X33	1	

HONDA GX160UT2SCM ENGINE — PISTON ASSY.

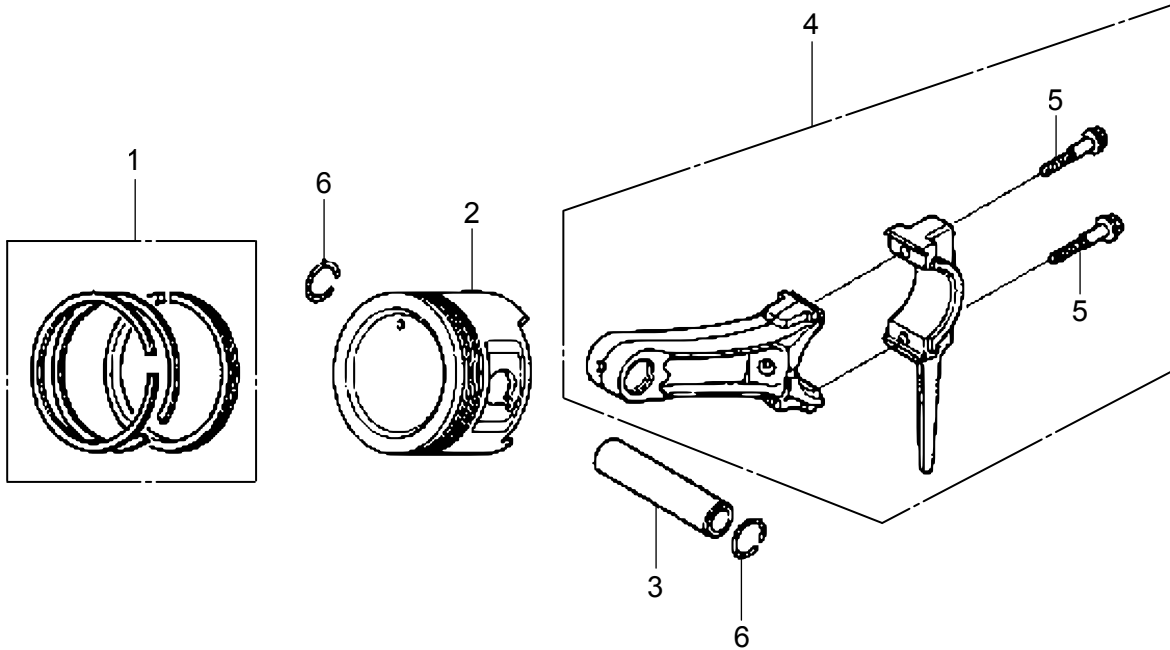

HONDA GX160UT2SCM ENGINE — PISTON ASSY.

<u>NO.</u>	<u>PART NO.</u>	<u>PART NAME</u>	<u>QTY.</u>	<u>REMARKS</u>
1	13010Z4M801	RING SET, PISTON (STD)	1	
1	13011Z4M003	RING SET, PISTON 0.25	1	
1	13012Z4M003	RING SET, PISTON 0.50	1	
2	13101Z4M800	PISTON (STD)	1	
2	13102Z4M800	PISTON 0.25	1	
2	13103Z4M800	PISTON 0.50	1	
3	13111Z4M000	PIN, PISTON	1	
4	13200Z0T900	ROD ASSY., CONNECTING.....	1	INCLUDES ITEM W/\$
5\$	90001Z4M000	BOLT, CONNECTING ROD 6X34.5	2	
6	90551ZE1000	CLIP, PISTON PIN 18MM	2	

HONDA GX160UT2SCM ENG. — CAMSHAFT ASSY.

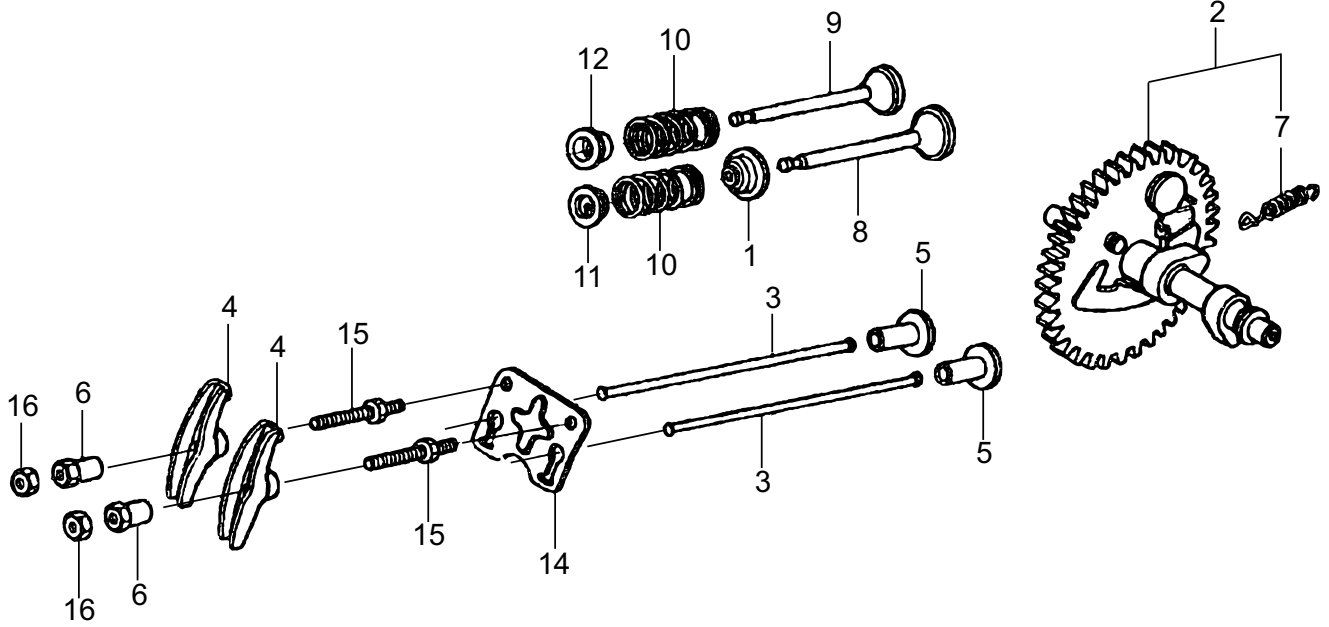

HONDA GX160UT2SCM ENG. — CAMSHAFT ASSY.

<u>NO.</u>	<u>PART NO.</u>	<u>PART NAME</u>	<u>QTY.</u>	<u>REMARKS</u>
1	12209Z4M801	SEAL, VALVE STEM	1	
2	14100Z4M000	CAMSHAFT ASSY.....	1	INCLUDES ITEM W/\$
3	14410Z4M000	ROD COMPLETE, PUSH	2	
4	14431ZE1000	ARM, VALVE ROCKER	2	
5	14441ZE1010	VALVE LIFTER	2	
6	14451Z4M000	PIVOT, ROCKER ARM	2	
7\$	14568ZE1000	SPRING, WEIGHT RETURN	1	
8	14711Z4M000	VALVE, INTAKE	1	
9	14721Z4M000	VALVE, EXHAUST	1	
10	14751ZF1000	SPRING, VALVE	2	
11	14771Z0T900	RETAINER, SPRING VALVE	1	
12	14771Z0T900	RETAINER, SPRING VALVE	1	
14	14791Z4M000	PLATE, PUSH ROD GUIDE	1	
15	90012ZE0010	BOLT, PIVOT, 8MM	2	
16	90206ZE1000	NUT, PIVOT ADJUSTING	2	

HONDA GX160UT2SCM ENG. — RECOIL STARTER ASSY.

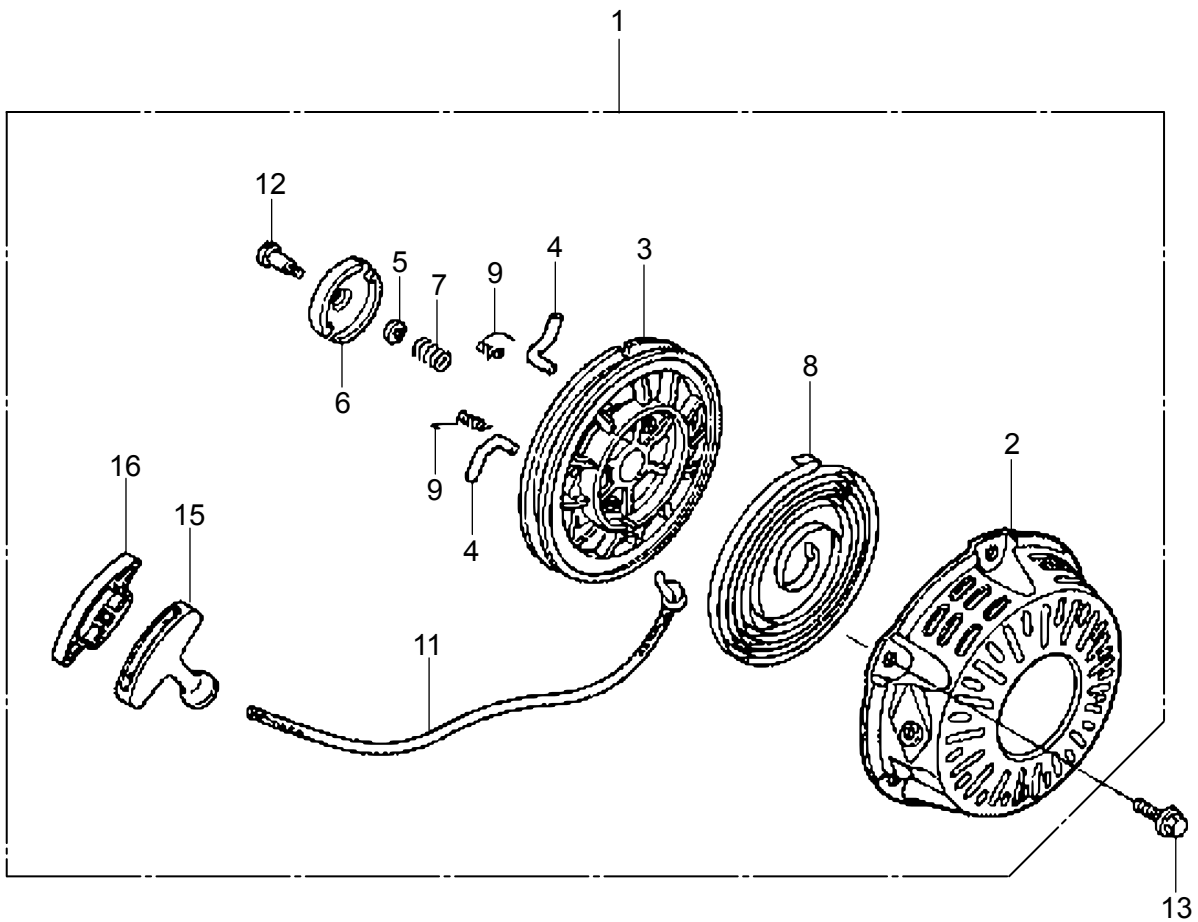

HONDA GX160UT2SCM ENG. — RECOIL STARTER ASSY.

<u>NO.</u>	<u>PART NO.</u>	<u>PART NAME</u>	<u>QTY.</u>	<u>REMARKS</u>
1	28400Z4M801ZD	STARTER ASSY., RECOIL	1.....	INCLUDES ITEMS W/\$
2\$	28410Z4M003ZD	CASE COMPLETE, RECOIL STARTER	1	
3\$	28421Z1T702	REEL, RECOIL STARTER	1	
4\$	28422Z1T701	RATCHET, STARTER	2	
5\$	28431ZH8801	PLATE, FRICTION	1	
6\$	28433Z1T702	RATCHET GUIDE	1	
7\$	28441ZH8801	FRICTION SPRING	1	
8\$	28442ZH8003	SPRING, RECOIL STARTER	1	
9\$	28443Z1T701	SPRING, RETURN	2	
11\$	28462ZH8003	ROPE, RECOIL STARTER	1	
12\$	90003ZH8801	SET SCREW	1	
13	957010600800	BOLT, FLANGE 6X8	3	
15\$	28461Z4M305	KNOB, RECOIL STARTER	1	
16\$	28463Z4M003	KNOB, REINFORCEMENT	1	

HONDA GX160UT2SCM ENG. — FAN COVER ASSY.

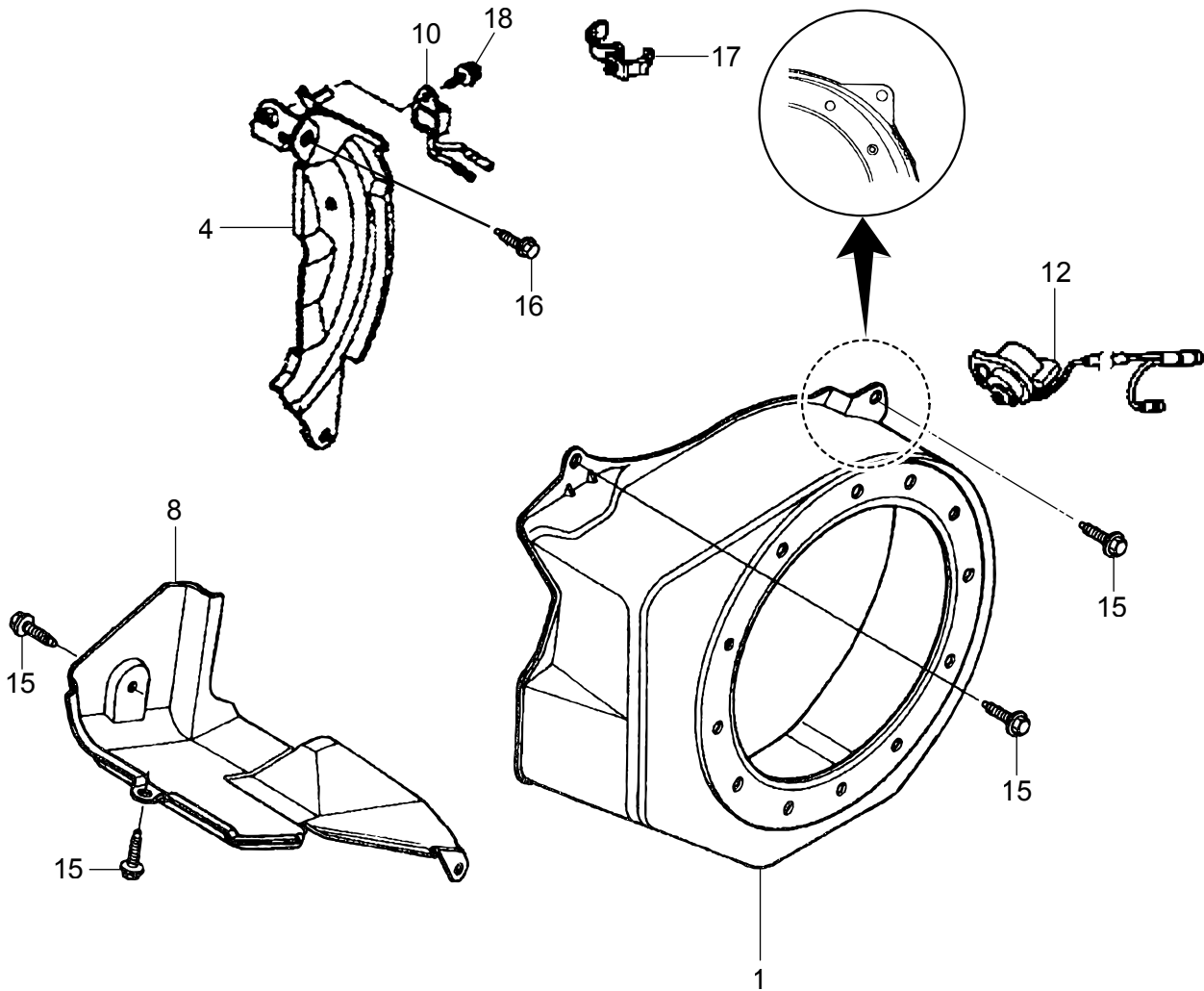

HONDA GX160UT2SCM ENG. — FAN COVER ASSY.

<u>NO.</u>	<u>PART NO.</u>	<u>PART NAME</u>	<u>QTY.</u>	<u>REMARKS</u>
1	19610Z4M000ZB	COVER COMPLETE, FAN	1	
4	19611Z4M810	PLATE COMPLETE, SIDE (OIL ALERT)	1	
8	19630Z4M000	SHROUD COMPLETE	1	
10	34150ZH7023	ALERT UNIT, OIL	1	
12	35120Z0T831	SWITCH ASSY., E/G STOP	1	
15	90013883000	FLANGE BOLT 6X12	6	
16	90022888010	FLANGE BOLT 6X20	1	
17	90601ZH7013	CLIP, HARNESS	1	
18	957010600800	FLANGE BOLT 6X8	1	

HONDA GX160UT2SCM ENG. — CARBURETOR ASSY.

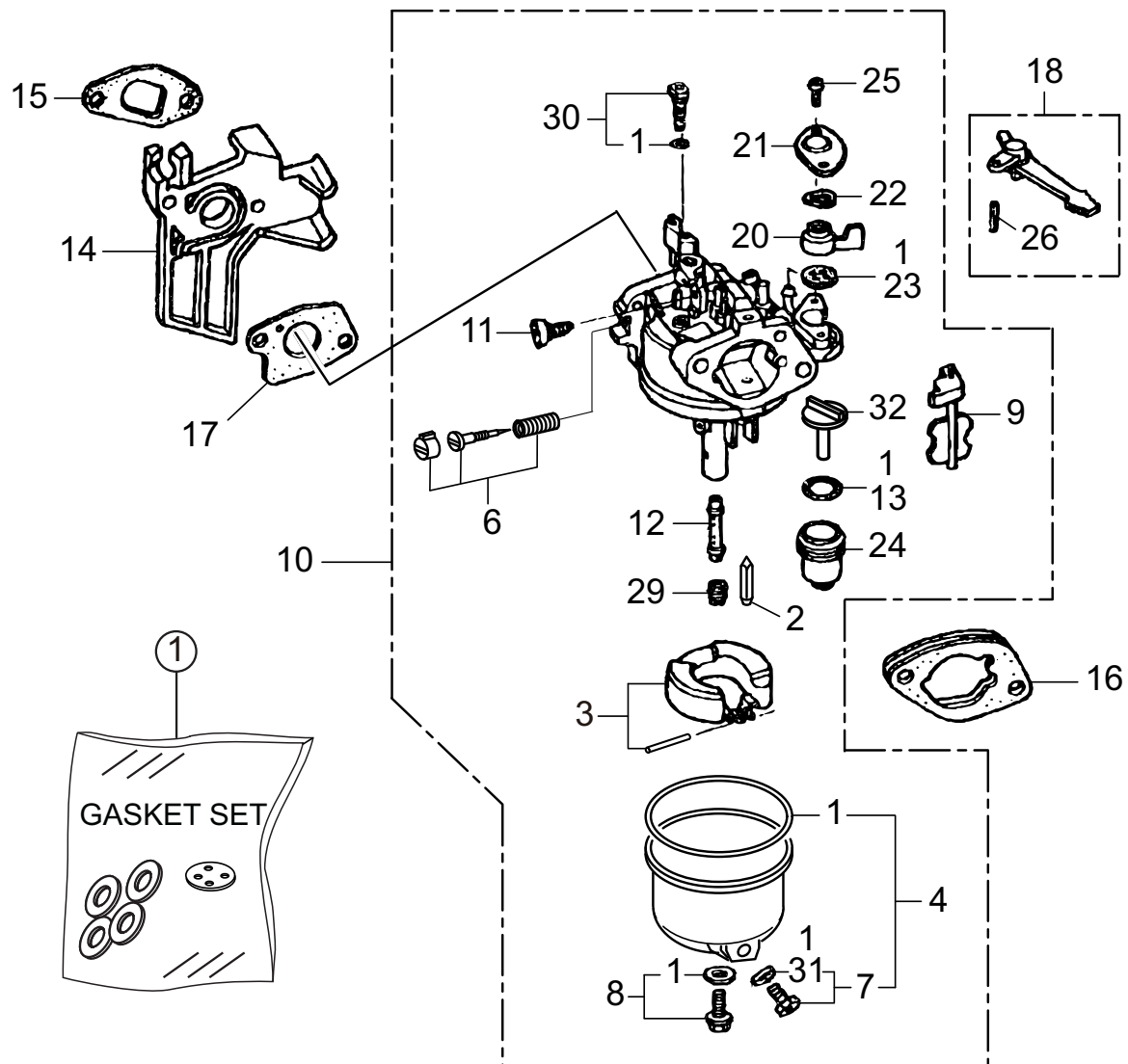

NOTICE

Gasket set, item 1 included with items 4, 7, 8, 13, 23, 30 and 31.

HONDA GX160UT2SCM ENG. — CARBURETOR ASSY.

<u>NO.</u>	<u>PART NO.</u>	<u>PART NAME</u>	<u>QTY.</u>	<u>REMARKS</u>
1#%	16010ZE1812	GASKET SET	1	
2#	16011ZE0005	FLOAT VALVE SET	1	
3#	16013Z0SB01	FLOAT SET	1	
4#	16015Z4M911	CHAMBER SET, FLOAT	1	INCLUDES ITEM W/%, &
6#	16016ZH7W01	SCREW SET, PILOT	1	
7#&	16024Z5T901	SCREW SET, DRAIN	1	INCLUDES ITEM W/%
8#	16028Z5T901	SCREW SET	1	INCLUDES ITEM W/%
9#	16044Z4M911	CHOKE SET	1	
10	16100Z4M781	CARBURETOR ASSY.....	1	INCLUDES ITEMS W/#
11#	16124ZE0005	SCREW, THROTTLE STOP	1	
12#	16166Z4M781	NOZZLE, MAIN	1	
13#	16955283000	PACKING, CUP	1	INCLUDES ITEM W/%
				REPLACES P/N 16173001004
14	16211Z4M000	INSULATOR, CARBURETOR	1	
15	16212ZH8800	PACKING, INSULATOR	1	
16	16220ZE1020	SPACER COMPLETE, CARBURETOR	1	
17	16221ZH8801	PACKING, CARBURETOR	1	
18	16610ZE1000	CHOKE LEVER COMPLETE	1	INCLUDES ITEM W/\$
20#	16953ZE1812	LEVER, COCK	1	
21#	16954ZE1812	PLATE, LEVER SETTING	1	
22#	16956ZE1811	SPRING, COCK LEVER	1	
23#	16957ZE1812	PACKING, FUEL COCK	1	INCLUDES ITEM W/%
24#	16967ZE0811	CUP, FUEL STRAINER	1	
25#	93500030060H	SCREW 3X6	2	
26\$	9430520122	SPRING PIN 2X12	1	
29#	99101ZH80720	MAIN JET #72	1	
30#	99204ZE20400	PILOT, JET SET #40	1	INCLUDES ITEM W/%
31#	16141Z0S003	WASHER, FLAT.....	1	INCLUDES ITEM W/%
32#	16959Z5T901	FILTER, CUP	1	

HONDA GX160UT2SCM ENGINE — AIR CLEANER ASSY.

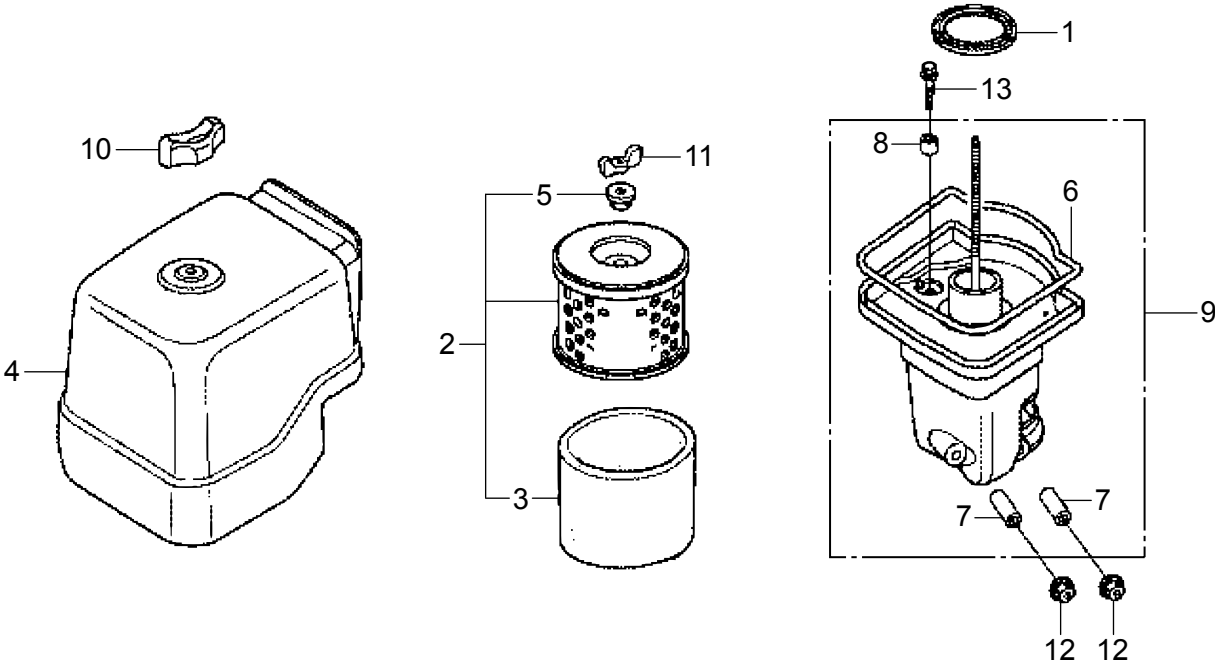

HONDA GX160UT2SCM ENGINE — AIR CLEANER ASSY.

<u>NO.</u>	<u>PART NO.</u>	<u>PART NAME</u>	<u>QTY.</u>	<u>REMARKS</u>
1	16271ZE1000	PACKING, ELBOW	1	
2	17210Z0V781	ELEMENT	1	INCLUDES ITEMS W/\$
3\$	17218Z0V780	FILTER, OUTER	1	
4	17230Z0V780	COVER ASSY.	1	
5\$	17232891000	GROMMET	1	
6%	17233Z0V780	SEAL, AIR CLEANER COVER	1	
7%	17238ZE7010	COLLAR	2	
8%	17239ZE3840	COLLAR B	1	
9	17410Z0V780	ELBOW COMPLETE	1	INCLUDES ITEMS W/%
10	90300Z4M800	WING NUT	1	
11	90325044000	WING NUT	1	
12	9405006000	FLANGE NUT 6MM	2	
13	957010602000	FLANGE BOLT 6X20	1	

HONDA GX160UT2SCM ENGINE — MUFFLER ASSY.

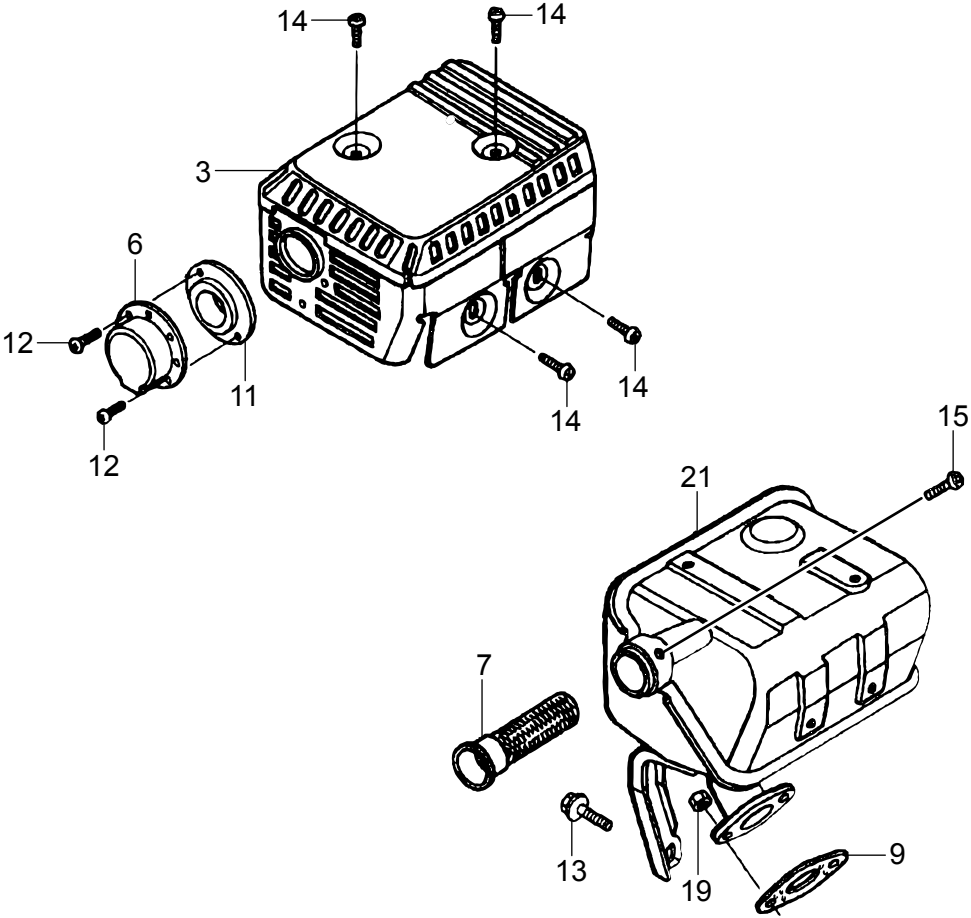

HONDA GX160UT2SCM ENGINE — MUFFLER ASSY.

<u>NO.</u>	<u>PART NO.</u>	<u>PART NAME</u>	<u>QTY.</u>	<u>REMARKS</u>
3	18320Z4M000	PROTECTOR COMPLT., MUFFLER (STD)	1	
6	18340ZE1010	DEFLECTOR COMPLETE	1	
7	18355ZE1000	ARRESTER, SPARK	1	
9	18381Z0T801	GASKET, MUFFLER	1	
11	18522ZE1000	GUIDE, MUFFLER	1	
12	90002Z0T800	SCREW, TAPPING, 4X8	2	
13	90016ZE1000	FLANGE, BOLT 6X13	1	
14	90050ZE1000	SCREW, TAPPING, 5X8	4	
15	90055ZE1000	SCREW, TAPPING, 4X6	1	
19	94001080000S	NUT 8MM	2	
21	18310Z4MV51	MUFFLER COMPLETE	1	

HONDA GX160UT2SCM ENGINE — FUEL TANK ASSY.

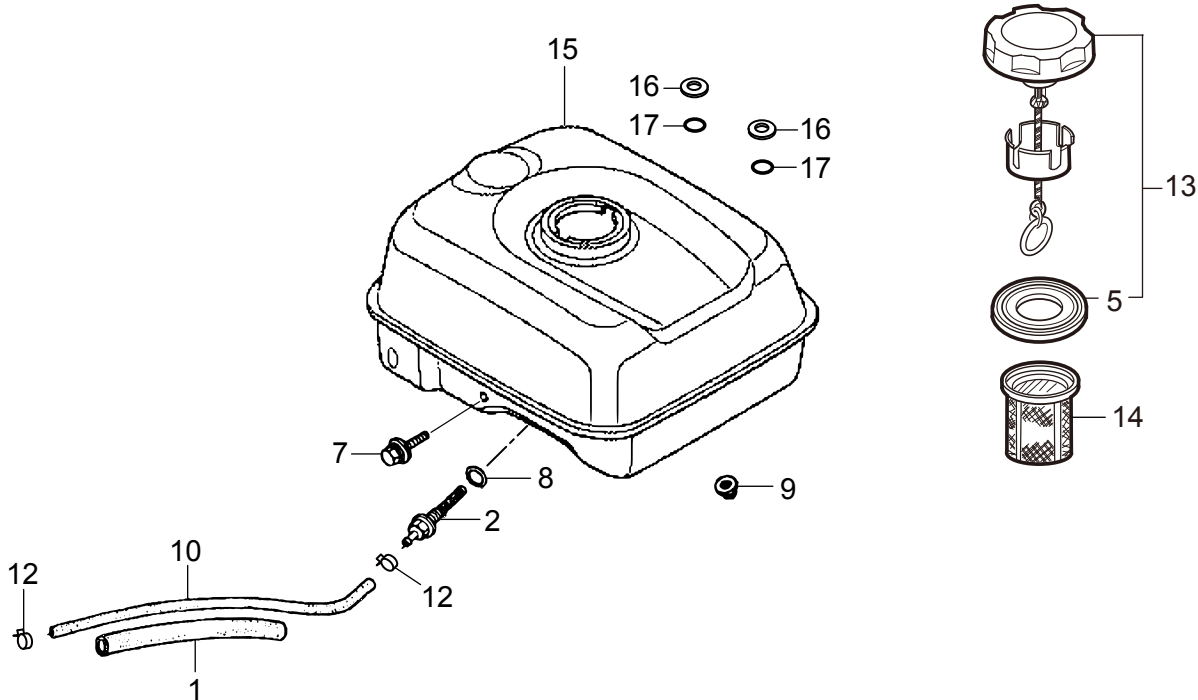

HONDA GX160UT2SCM ENGINE — FUEL TANK ASSY.

<u>NO.</u>	<u>PART NO.</u>	<u>PART NAME</u>	<u>QTY.</u>	<u>REMARKS</u>
1	16854ZH8000	RUBBER, SUPPORT (107MM)	1	
2	16955ZE1010	JOINT, FUEL TANK	1	
5%	17631Z0T801	PACKING, FUEL FILLER CAP	1	
7	90004ZH7003	FLANGE BOLT, 6X29	1	
8	91353671003	O-RING, 14MM.....	1	REPLACES P/N 91353671004
9	9405006000	FLANGE NUT, 6MM	2	
10	91424Z4M003	TUBE, FUEL 4.5X145	1	
12	950024080008	CLAMP, TUBE (D8)	2	
13	17620Z4H900	CAP COMPLETE, FUEL TANK.....	1	INCLUDES ITEM W/%
14	17672Z4H000	FUEL FILTER, FUEL TANK	1	
15	17510Z4M000ZB	FUEL TANK COMPLETE, NH1, BLK	1	
16	90503898000	WASHER, TANK CUSHION	2	
17	91302Z4M003	O-RING 5.5X1.5	2	

HONDA GX160UT2SCM ENGINE — FLYWHEEL ASSY.

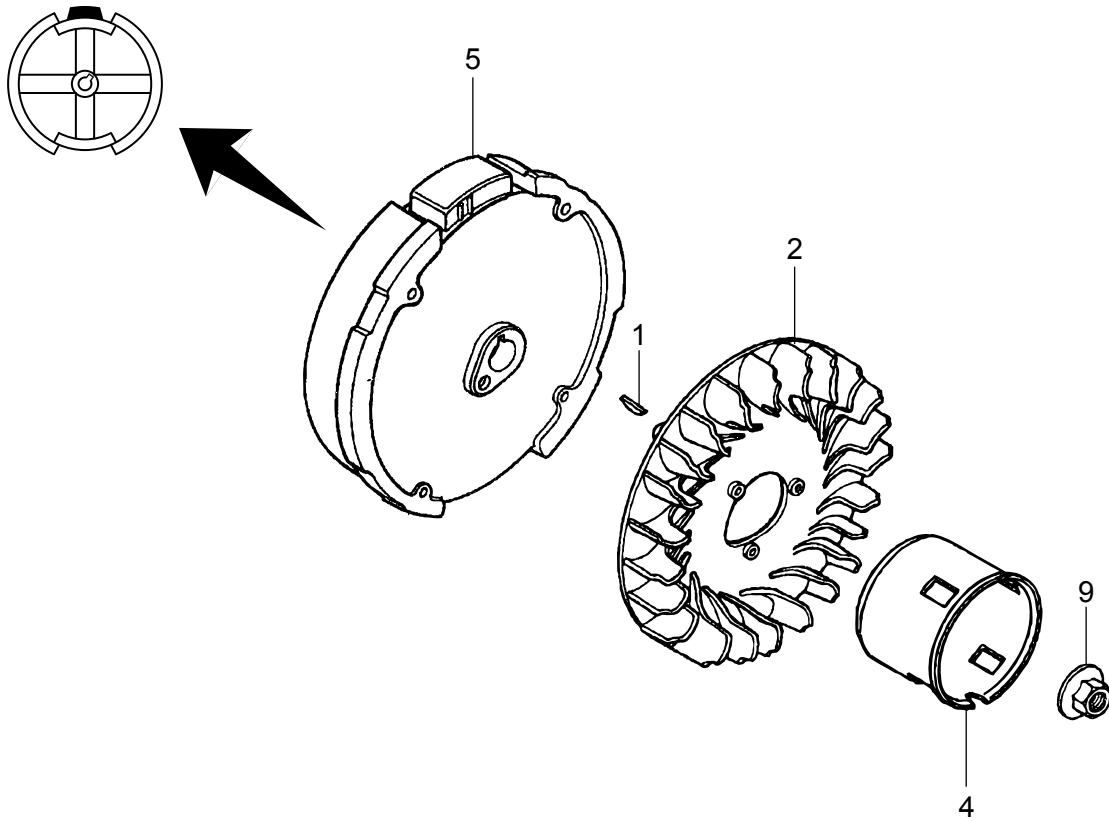

HONDA GX160UT2SCM ENGINE — FLYWHEEL ASSY.

<u>NO.</u>	<u>PART NO.</u>	<u>PART NAME</u>	<u>QTY.</u>	<u>REMARKS</u>
1	13331357000	WOODRUFF KEY 25X18	1	
2	19511ZE1000	COOLING FAN	1	
4	28451Z4M003	STARTER, PULLEY	1	
5	31110Z4M000	FLYWHEEL COMPLETE	1	
9	90201Z0T800	NUT, SPECIAL 14MM	1	

HONDA GX160UT2SCM ENGINE — IGNITION COIL ASSY.

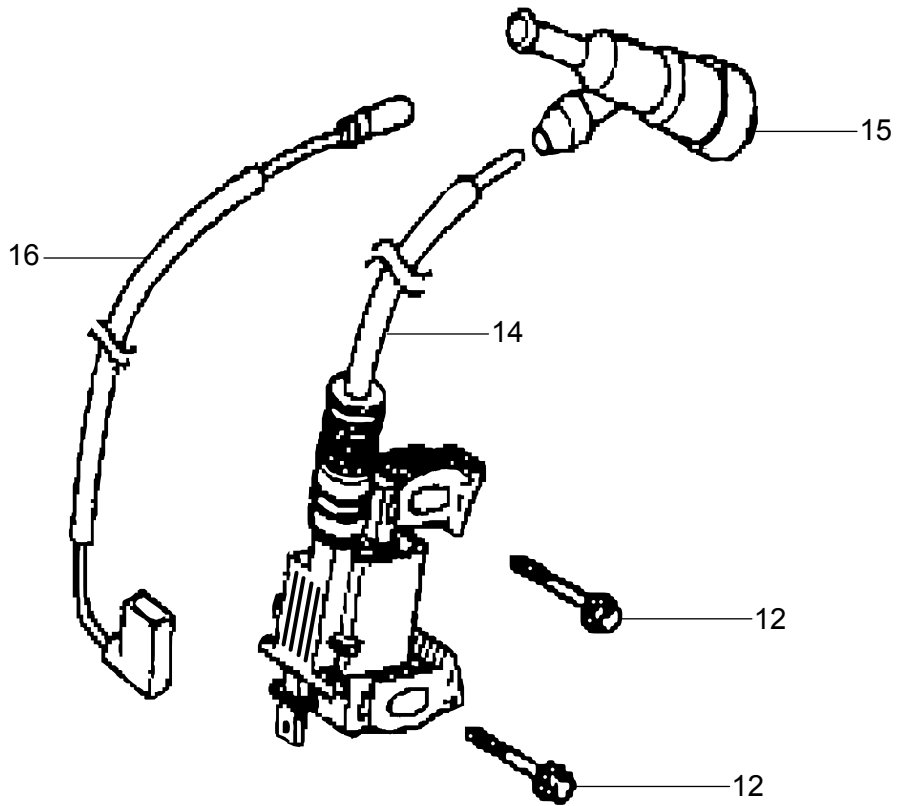

HONDA GX160UT2SCM ENGINE — IGNITION COIL ASSY.

<u>NO.</u>	<u>PART NO.</u>	<u>PART NAME</u>	<u>QTY.</u>	<u>REMARKS</u>
12	957010602500	FLANGE BOLT 6X25	2.....	REPLACES P/N 90121952000
14	30500Z0T003	COIL ASSY., IGNITION	1	
15	30700Z0T812	CAP ASSY., NOISE SUPPRESSOR	1	
16	32195Z0T003	CORD, STOP SWITCH 370MM	1	

HONDA GX160UT2SCM ENGINE — CONTROL ASSY.

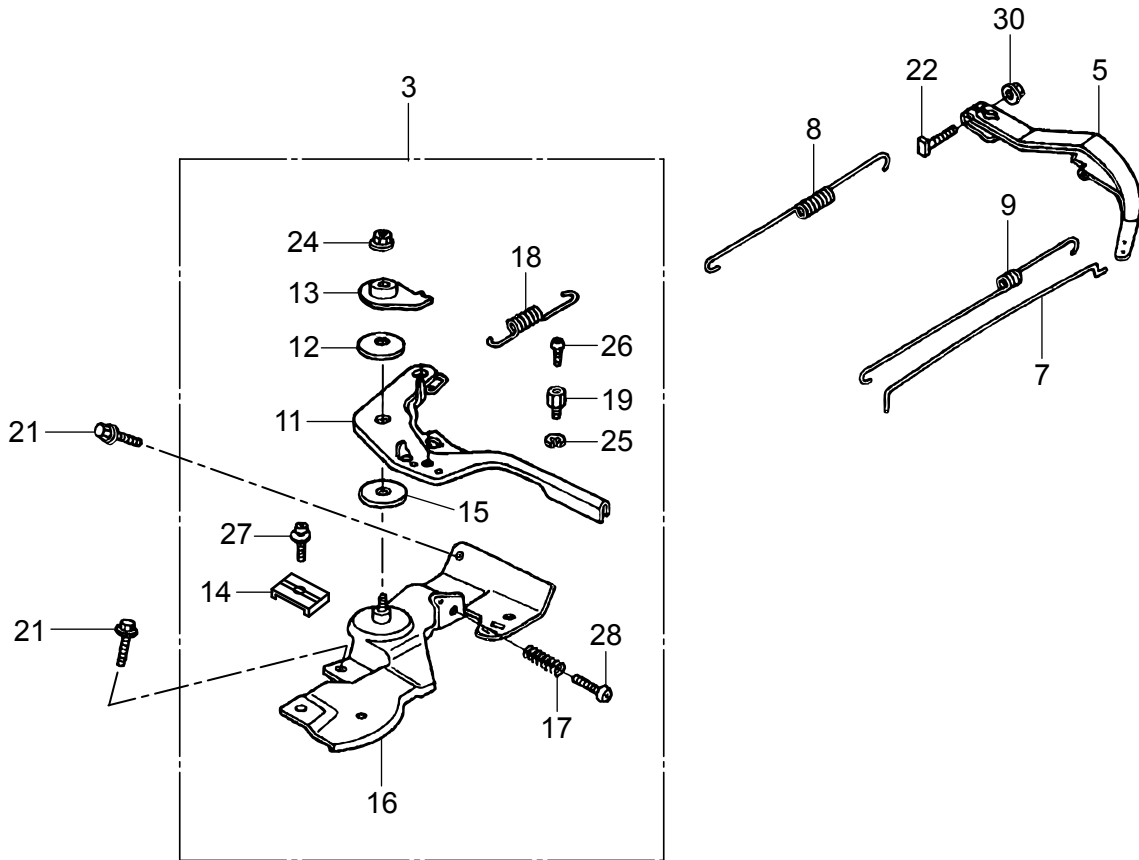

HONDA GX160UT2SCM ENGINE — CONTROL ASSY.

<u>NO.</u>	<u>PART NO.</u>	<u>PART NAME</u>	<u>QTY.</u>	<u>REMARKS</u>
3	16500Z0V780	CONTROL ASSY.....	1.....	INCLUDES ITEMS W/#
5	16551Z4M000	ARM, GOVERNOR	1	
7	16555Z4M000	ROD, GOVERNOR	1	
8	16561Z4M010	SPRING, GOVERNOR	1	
9	16562Z4M000	SPRING, THROTTLE RETURN	1	
11#	16571Z4M000	LEVER, CONTROL	1	
12#	16574ZE1000	LEVER, SPRING	1	
13#	16575ZH8000	WASHER, CONTROL LEVER	1	
14#	16576891000	HOLDER, CABLE	1	
15#	16578ZE1000	SPACER, CONTROL LEVER	1	
16#	16580Z0V780	BASE COMPLETE, CONTROL	1	
17#	16584883300	ADJUSTING SPRING	1	
18#	16592ZE1810	SPRING, CABLE, RETURN	1	
19#	16594883010	HOLDER, WIRE	1	
21	90013883000	FLANGE BOLT 6X12	2	
22	90015Z5T000	BOLT, GOVERNOR ARM	1	
24#	90114SA0000	LOCK NUT 6MM	1	
25#	90605230000	CIR CLIP	1	
26#	0043504060	SCREW 4X6	1.....	REPLACES P/N 93500040060H
27#	0202005T125	SCREW 5X16	1.....	REPLACES P/N 93500050160A
28#	93500050250H	SCREW 5X25	1	
30	9405006000	FLANGE NUT 6MM	1	

HONDA GX160UT2SCM ENGINE — DECALS ASSY.

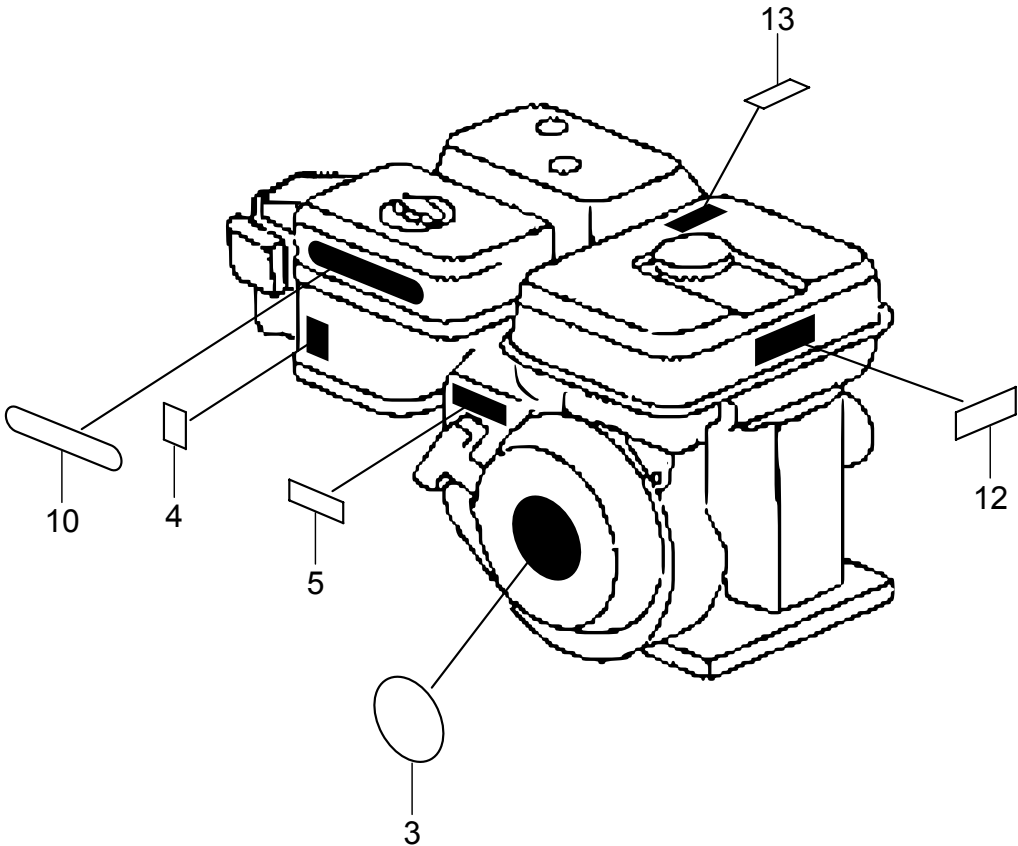

HONDA GX160UT2SCM ENGINE — DECALS ASSY.

<u>NO.</u>	<u>PART NO.</u>	<u>PART NAME</u>	<u>QTY.</u>	<u>REMARKS</u>
3	87521Z4M000	EMBLEM (GX160)	1	
4	87528Z4M000	MARK, CHOKE	1	
5	87532ZH7000	MARK, THROTTLE INDICATION	1	
10	87602Z0V780	MARK, SALES POINT	1	
12	87516Z4H010	MARK, OP CAUTION	1	
13	87539Z4M000	MARK, EX. CAUTION	1	

PARTS MANUAL

HERE'S HOW TO GET HELP

PLEASE HAVE THE MODEL AND SERIAL
NUMBER ON-HAND WHEN CALLING

UNITED STATES

Multiquip Inc.

(310) 537- 3700
6141 Katella Avenue Suite 200
Cypress, CA 90630
E-MAIL: mq@multiquip.com
WEBSITE: www.multiquip.com

CANADA

Multiquip

(450) 625-2244
4110 Industriel Boul.
Laval, Quebec, Canada H7L 6V3
E-MAIL: infocanada@multiquip.com

UNITED KINGDOM

Multiquip (UK) Limited Head Office

0161 339 2223
Unit 2, Northpoint Industrial Estate,
Globe Lane,
Dukinfield, Cheshire SK16 4UJ
E-MAIL: sales@multiquip.co.uk

© COPYRIGHT 2020, MULTIQUIP INC.

Multiquip Inc, the MQ logo are registered trademarks of Multiquip Inc. and may not be used, reproduced, or altered without written permission. All other trademarks are the property of their respective owners and used with permission.

This manual MUST accompany the equipment at all times. This manual is considered a permanent part of the equipment and should remain with the unit if resold.

The information and specifications included in this publication were in effect at the time of approval for printing. Illustrations, descriptions, references and technical data contained in this manual are for guidance only and may not be considered as binding. Multiquip Inc. reserves the right to discontinue or change specifications, design or the information published in this publication at any time without notice and without incurring any obligations.

Your Local Dealer is:

