

OPERATION MANUAL



Mikasa SERIES
MODEL MVH308DE
REVERSIBLE PLATE COMPACTOR
(HATZ 1B30E DIESEL ENGINE)

Revision #0 (09/06/22)

To find the latest revision of this publication or associated parts manual, visit our website at:
www.multiquip.com



THIS MANUAL MUST ACCOMPANY THE EQUIPMENT AT ALL TIMES.

PROPOSITION 65 WARNING



**MVH308DE Reversible
Plate Compactor**

Proposition 65 Warning 2
Safety Information 5-9
Specifications 10
Dimensions..... 11
General Information..... 12
Components 14-15
Basic Engine..... 16
Inspection 17-19
Startup..... 20-21
Operation..... 22-23
Maintenance 25-31
Troubleshooting (Compactor) 32
Troubleshooting (Engine)..... 33-34
Wiring Diagram..... 35

NOTICE

Specifications and part numbers are subject to change without notice.

SAFETY INFORMATION

Do not operate or service the equipment before reading the entire manual. Safety precautions should be followed at all times when operating this equipment. Failure to read and understand the safety messages and operating instructions could result in injury to yourself and others.



SAFETY MESSAGES

The four safety messages shown below will inform you about potential hazards that could injure you or others. The safety messages specifically address the level of exposure to the operator and are preceded by one of four words: **DANGER**, **WARNING**, **CAUTION** or **NOTICE**.

SAFETY SYMBOLS

! DANGER

Indicates a hazardous situation which, if not avoided, **WILL** result in **DEATH** or **SERIOUS INJURY**.

! WARNING

Indicates a hazardous situation which, if not avoided, **COULD** result in **DEATH** or **SERIOUS INJURY**.







! CAUTION

Indicates a hazardous situation which, if not avoided, **COULD** result in **MINOR** or **MODERATE INJURY**.

NOTICE

Addresses practices not related to personal injury.

Potential hazards associated with the operation of this equipment will be referenced with hazard symbols which may appear throughout this manual in conjunction with safety messages.

Symbol	Safety Hazard
	Lethal exhaust gas hazards
	Explosive fuel hazards
	Burn hazards
	Respiratory hazards
	Accidental starting hazards
	Eye and hearing hazards
	Rotating parts hazards

SAFETY INFORMATION

GENERAL SAFETY

CAUTION

- **NEVER** operate this equipment without proper protective clothing, shatterproof glasses, respiratory protection, hearing protection, steel-toed boots and other protective devices required by the job or city and state regulations.



- **NEVER** operate this equipment when not feeling well due to fatigue, illness or when under medication. 
- **NEVER** operate this equipment under the influence of drugs or alcohol.



- **ALWAYS** check the equipment for loosened threads or bolts before starting.
- **DO NOT** use the equipment for any purpose other than its intended purposes or applications.
- **ALWAYS** clear the work area of any debris, tools, etc. that would constitute a hazard while the equipment is in operation.

NOTICE

- This equipment should only be operated by trained and qualified personnel 18 years of age and older.
- Whenever necessary, replace nameplate, operation and safety decals when they become difficult read.
- Manufacturer does not assume responsibility for any accident due to equipment modifications. Unauthorized equipment modification will void all warranties.
- **NEVER** use accessories or attachments that are not recommended by Multiquip for this equipment. Damage to the equipment and/or injury to user may result.
- **ALWAYS** know the location of the nearest **fire extinguisher**. 
- **ALWAYS** know the location of the nearest **first aid kit**. 
- **ALWAYS** know the location of the nearest phone or **keep a phone on the job site**. Also, know the phone numbers of the nearest **ambulance, doctor and fire department**. This information will be invaluable in the case of an emergency.

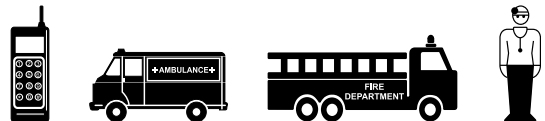

SAFETY INFORMATION

COMPACTOR SAFETY

DANGER

- **NEVER** operate the equipment in an explosive atmosphere or near combustible materials. An explosion or fire could result causing severe bodily harm or even death.



WARNING

- **NEVER** disconnect any **emergency or safety devices**. These devices are intended for operator safety. Disconnection of these devices can cause severe injury, bodily harm or even death. Disconnection of any of these devices will void all warranties.

CAUTION

- **NEVER** lubricate components or attempt service on a running machine.

NOTICE

- **ALWAYS** keep the machine in proper running condition.
- Fix damage to machine and replace any broken parts immediately.
- **ALWAYS** store equipment properly when it is not being used. Equipment should be stored in a clean, dry location out of the reach of children and unauthorized personnel.

ENGINE SAFETY

DANGER

- The engine fuel exhaust gases contain poisonous carbon monoxide. This gas is colorless and odorless, and can cause death if inhaled.
- The engine of this equipment requires an adequate free flow of cooling air. **NEVER** operate this equipment in any enclosed or narrow area where free flow of the air is restricted. If the air flow is restricted it will cause injury to people and property and serious damage to the equipment or engine.



WARNING

- **DO NOT** place hands or fingers inside engine compartment when engine is running.
- **NEVER** operate the engine with heat shields or guards removed.
- Keep fingers, hands hair and clothing away from all moving parts to prevent injury.
- **DO NOT** remove the radiator cap while the engine is hot. High pressure boiling water will gush out of the radiator and severely scald any persons in the general area of the compactor.
- **DO NOT** remove the coolant drain plug while the engine is hot. Hot coolant will gush out of the coolant tank and severely scald any persons in the general area of the compactor.
- **DO NOT** remove the engine oil drain plug while the engine is hot. Hot oil will gush out of the oil tank and severely scald any persons in the general area of the compactor.



CAUTION

- **NEVER** touch the hot exhaust manifold, muffler or cylinder. Allow these parts to cool before servicing equipment.



NOTICE

- **NEVER** run engine without an air filter or with a dirty air filter. Severe engine damage may occur. Service air filter frequently to prevent engine malfunction.
- **NEVER** tamper with the factory settings of the engine or engine governor. Damage to the engine or equipment can result if operating in speed ranges above the maximum allowable.
- **NEVER** tip the engine to extreme angles during lifting as it may cause oil to gravitate into the cylinder head, making the engine start difficult.



SAFETY INFORMATION

FUEL SAFETY

DANGER

- **DO NOT** add fuel to equipment if it is placed inside truck bed with plastic liner. Possibility exists of explosion or fire due to static electricity.

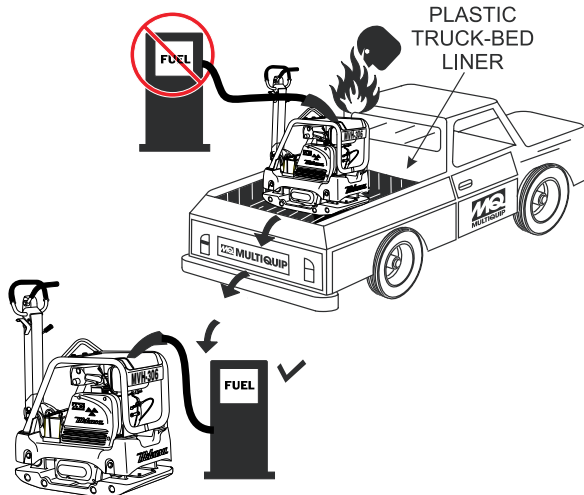

- **DO NOT** start the engine near spilled fuel or combustible fluids. Diesel fuel is extremely flammable and its vapors can cause an explosion if ignited.
- **ALWAYS** refuel in a well-ventilated area, away from sparks and open flames.
- **ALWAYS** use extreme caution when working with **flammable** liquids.
- **DO NOT** fill the fuel tank while the engine is running or hot.
- **DO NOT** overfill tank, since spilled fuel could ignite if it comes into contact with hot engine parts or sparks from the ignition system.
- Store fuel in appropriate containers, in well-ventilated areas and away from sparks and flames.
- **NEVER** use fuel as a cleaning agent.
- **DO NOT** smoke around or near the equipment. Fire or explosion could result from fuel vapors or if fuel is spilled on a hot engine.



BATTERY SAFETY (ELECTRIC START ONLY)

DANGER

- **DO NOT** drop the battery. There is a possibility that the battery will explode.
- **DO NOT** expose the battery to open flames, sparks, cigarettes, etc. The battery contains combustible gases and liquids. If these gases and liquids come into contact with a flame or spark, an explosion could occur.



WARNING

- **ALWAYS** wear safety glasses when handling the battery to avoid eye irritation. The battery contains acids that can cause injury to the eyes and skin.
- Use well-insulated gloves when picking up the battery.
- **ALWAYS** keep the battery charged. If the battery is not charged, combustible gas will build up.
- **DO NOT** charge battery if frozen. Battery can explode. When frozen, warm the battery to at least 61°F (16°C).
- **ALWAYS** recharge the battery in a well-ventilated environment to avoid the risk of a dangerous concentration of combustible gases.
- If the battery liquid (dilute sulfuric acid) comes into contact with **clothing or skin**, rinse skin or clothing immediately with plenty of water.
- If the battery liquid (dilute sulfuric acid) comes into contact with **eyes**, rinse eyes immediately with plenty of water and contact the nearest doctor or hospital to seek medical attention.



CAUTION

- **ALWAYS** disconnect the **NEGATIVE** battery terminal before performing service on the equipment.
- **ALWAYS** keep battery cables in good working condition. Repair or replace all worn cables.

SAFETY INFORMATION

TRANSPORTING SAFETY

CAUTION

- NEVER allow any person or animal to stand underneath the equipment while lifting.

NOTICE

- Before lifting, make sure that the equipment parts (hook and vibration insulator) are not damaged and screws are not loose or missing.
- Always make sure crane or lifting device has been properly secured to the lifting bail (hook) of the equipment.
- ALWAYS shutdown engine before transporting.
- NEVER lift the equipment while the engine is running.
- Tighten fuel tank cap securely and close fuel cock to prevent fuel from spilling.
- Use adequate lifting cable (wire or rope) of sufficient strength.
- Use one point suspension hook and lift straight upwards.
- DO NOT lift machine to unnecessary heights.
- ALWAYS tie down equipment during transport by securing the equipment with rope.

ENVIRONMENTAL SAFETY/DECOMMISSIONING

NOTICE

Decommissioning is a controlled process used to safely retire a piece of equipment that is no longer serviceable. If the equipment poses an unacceptable and unrepairable safety risk due to wear or damage or is no longer cost effective to maintain (beyond life-cycle reliability) and is to be decommissioned (demolition and dismantlement), be sure to follow rules below:

- DO NOT pour waste or oil directly onto the ground, down a drain or into any water source.
- Contact your country's Department of Public Works or recycling agency in your area and arrange for proper disposal of any electrical components, waste or oil associated with this equipment.



- When the life cycle of this equipment is over, remove battery and bring to appropriate facility for lead reclamation. Use safety precautions when handling batteries that contain sulfuric acid.
- When the life cycle of this equipment is over, it is recommended that the trowel frame and all other metal parts be sent to a recycling center.

Metal recycling involves the collection of metal from discarded products and its transformation into raw materials to use in manufacturing a new product.

Recyclers and manufacturers alike promote the process of recycling metal. Using a metal recycling center promotes energy cost savings.

EMISSIONS INFORMATION

NOTICE

The diesel engine used in this equipment has been designed to reduce harmful levels of carbon monoxide (CO), hydrocarbons (HC) and nitrogen oxides (NOx) contained in diesel exhaust emissions.

This engine has been certified to meet US EPA Evaporative emissions requirements in the installed configuration.

Attempting to modify or make adjustments to the engine emission system by unauthorized personnel without proper training could damage the equipment or create an unsafe condition.

Additionally, modifying the fuel system may adversely affect evaporative emissions, resulting in fines or other penalties.

Emission Control Label

The emission control label is an integral part of the emission system and is strictly controlled by regulations.

The label must remain with the engine for its entire life.

If a replacement emission label is needed, please contact your authorized Kohler Engine Distributor.

SPECIFICATIONS

Table 1. MVH308DE Specifications	
Centrifugal Force	9,217 lbf (41 kN)
Vibration Frequency	4,400 vpm (73 Hz)
Maximum Traveling Speed	85 ft/min (26 m/min)
Plate Size (W x L)	17.52 x 33.86 in (445 x 860 mm)
Plate Size (W x L) with extension plates	23.62 x 33.86 in (600 x 860 mm)
Recommended Battery Types	Centennial 51R-75, Interstate MT-51R Optima D51R
Battery Dimensions (LxWxH)	9.65 x 6.88 x 7.99 in. (245 x 175 x 203 mm)
Operating Weight	760.59 lbs. (345 kg.)
Operating Weight with extension plates	793.66 lbs. (360 kg.)

Table 2. Engine Specifications	
Engine Make	HATZ
Engine Model	1B30E
Engine Type	Air-cooled, 4 Cycle Diesel Engine
Cylinder Bore X Stroke	3.15 x 2.72 in. (80 x 69 mm)
Displacement	21.18 cu-in (347 cc)
Maximum Output	6.1 BHP (4.5 Kw) @ 3600 RPM
Fuel Tank Capacity	Approx. 1.4 U.S. gallons (5.3 liters)
Fuel Type	Diesel
Oil Capacity	1.27 qts (1.2 liters)
Starting Method	Recoil/Electric Start
Dry Net Weight	90 lbs (40.8 Kg)

Table 3. Noise and Vibration Emissions	
Measured Sound Power Level in dB(A)	107
Guaranteed Sound Power Level in dB(A)	108
Hand-Arm Vibration in m/s ²	5.5

NOTES:

1. Products are tested for vibration level in accordance with European Directives 2002/44/EC.
2. Test course (crushed gravel) is in compliance with European Directive EN500-4.
3. The above values are subject to change if machine is modified and/or the required regulations change.

DIMENSIONS

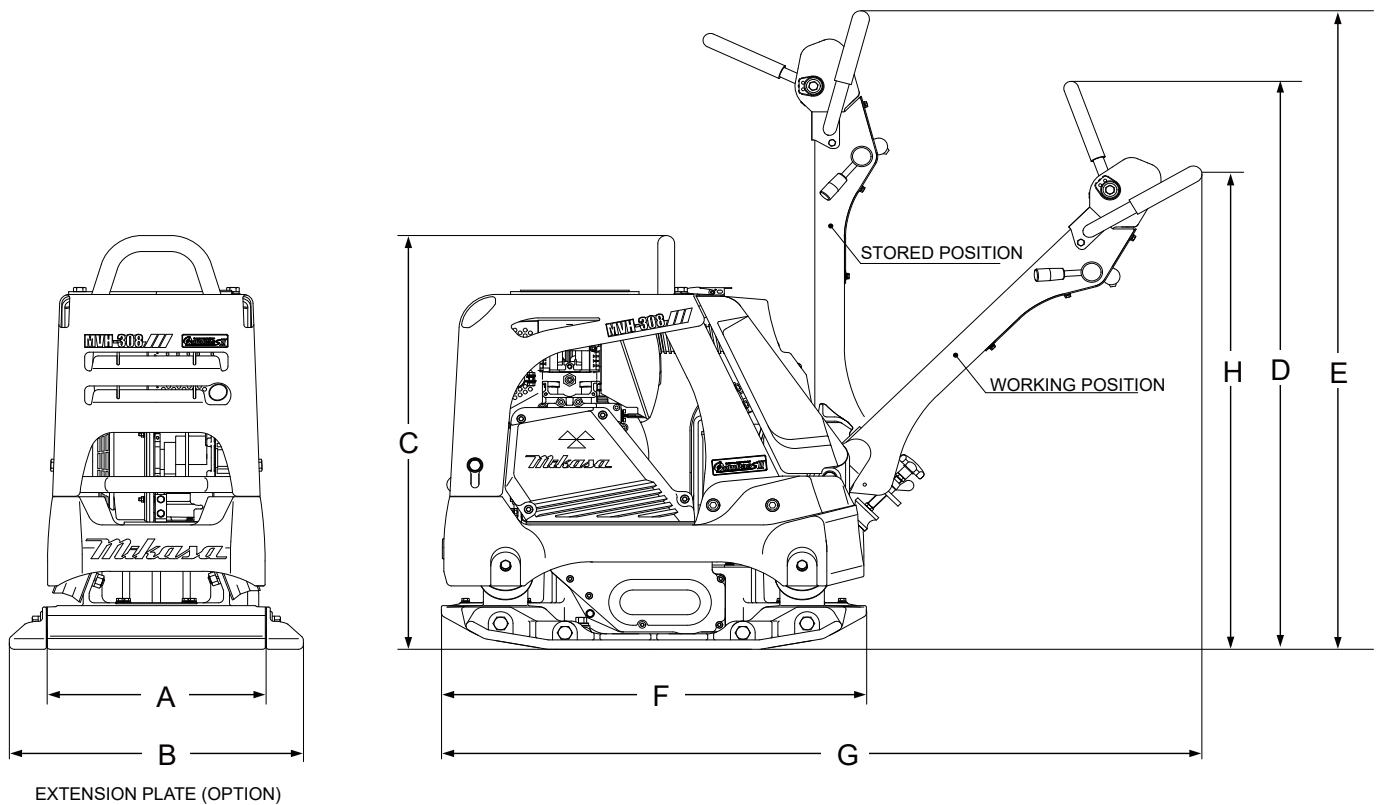

Figure 1. Dimensions

Table 4. Dimensions	
REF. DES	IN. (MM)
A	17.52 (445)
B	23.62 (600)
C	34.65 (880)
D	47.64 (1210)
E	53.54 (1360)
F	33.86 (860)
G	60.63 (1540)
H	40.55 (1030)

GENERAL INFORMATION

DEFINITION OF PLATE COMPACTOR

The Mikasa MVH308DE is a reversible plate compactor designed for efficient compaction of sand, gravel and cohesive soils. This plate compactor is a powerful compacting tool capable of applying a tremendous force in consecutive high frequency vibrations to a soil surface. Its applications include compacting for road, embankments and reservoirs as well as backfilling for gas pipelines, water pipelines and cable installation work.

VIBRATORY PLATES

The vibratory plates of the compactor produce low amplitude high frequency vibrations, designed to compact granular soils and asphalt.

The resulting vibrations cause forward motion. The engine and handle are vibration isolated from the vibrating plate.

FREQUENCY/SPEED

The compactor's vibrating plate produces a vibration frequency of 4,400 VPM (vibrations per minute). The travel speed of the compactor is approximately 85 ft/minute (26 meters/minute).

ENGINE

This plate compactor is equipped with a Hatz 1B30E air cooled, 4-cycle diesel engine. The engine drives an eccentric weight at a high speed to develop a compaction force.

NOTICE

The MVH308DE plate compactor is shipped from the factory **without the battery**. Battery can be purchased locally. Reference Table 1 for battery specifications.

CONTROLS

Before starting the plate compactor identify and understand the function of all the controls and components.

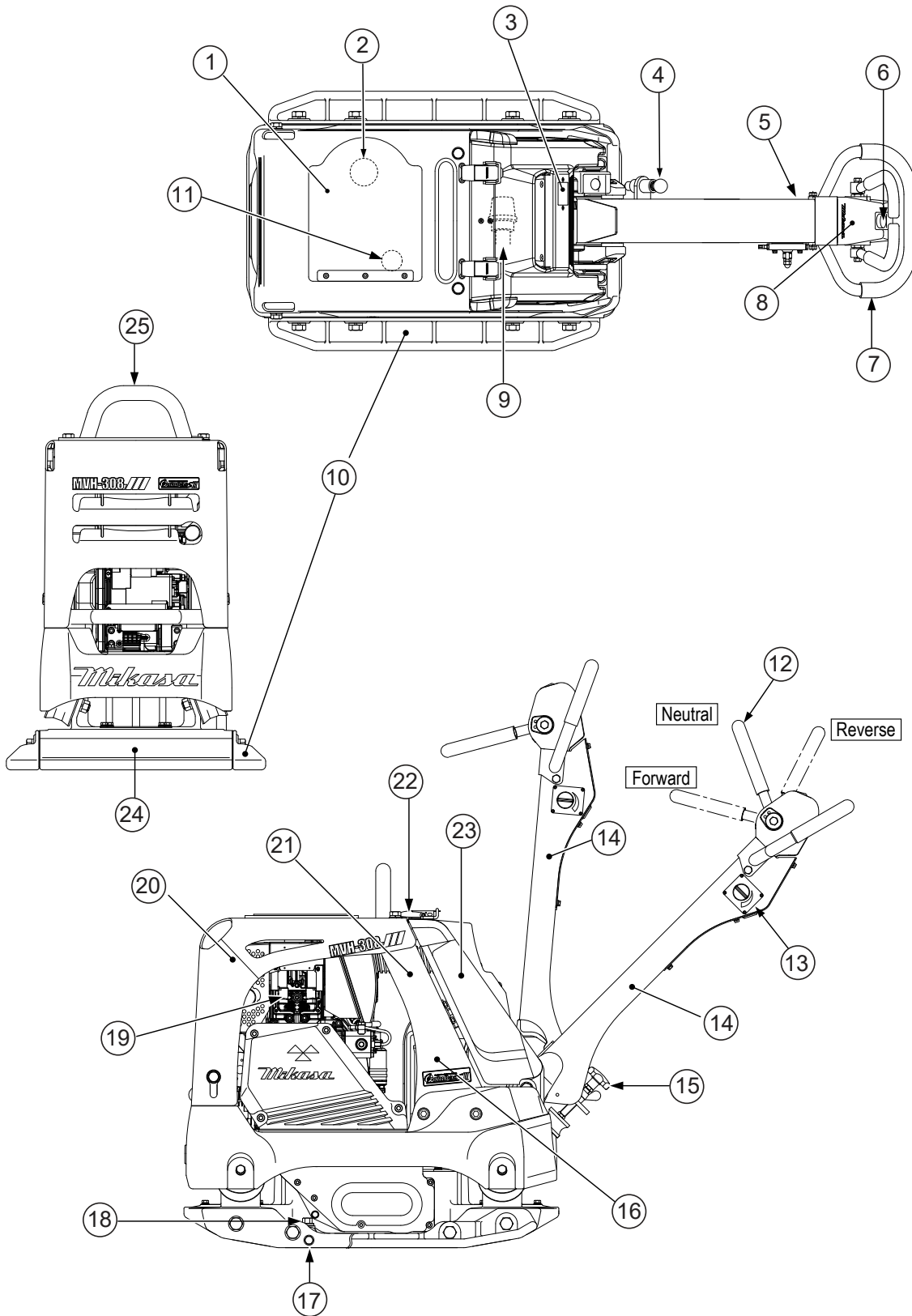

Figure 2. Plate Compactor Components

Figure 2 shows the location of the basic controls and components of the MVH308DE Plate Compactor. The function of each control is described below:

1. **Rubber Cover** — Lift this rubber cover to gain access to the fuel tank.
2. **Fuel Tank Cap** — Remove cap to add fuel to the unit.
3. **Hour/Tachometer** — Displays the cumulative time that the machine has been in use. During operation it displays the rpm reading. The tachometer also has a battery checker that lights red when the charge is low.
4. **Handle Lock** — Locks the handle in place when in the stored position.
5. **Key Switch** — Used to turn the engine on or off.
6. **Breather Plug** — Allow pressure to escape to the air in the form of a gas from heat.
7. **Hand Grip** — When operating the compactor use this hand grip to maneuver the compactor.
8. **Hydraulic Pump (Oil Reservoir)** — Regulates hydraulic oil flow produced by the direction of the control lever.
9. **Cyclone Cleaner** — Filters large dust particles to keep air cleaner from getting clogged easily.
10. **Extension Plate** — Provides additional area of vibration to the vibrating plate.
11. **Oil Filler for Engine** — Used to fill engine oil.
12. **Direction Control Lever (variable speed adjustable)** — *Push* the lever forward to move compactor in a forward direction. *Pull* the lever backwards to move compactor in backwards direction. Placing the lever in the middle (midway) will cause the compactor not to move (neutral).
13. **Throttle Knob** — Controls speed of the plate compactor. Place straight vertically to start, **push** fully counterclockwise for full throttle and fully clockwise to stop plate compactor.
14. **Handle** — When operating the compactor, this handle is to be in the downward position. When the compactor is to be **stored**, move the handle bar to the upright position.
15. **Grip (Handle Bar Height Adjuster)** — Adjusts the handle bar to the desired height by loosening the wing nut and turning the grip clockwise to raise the handle bar and counterclockwise to lower the handle bar.
16. **Battery** — Provides +12V DC to the electrical system.
17. **Vibrator Oil Drain Plug** — Used to drain vibrator oil from the machine.
18. **Vibration Case Oil Filler** — Used to add oil to the vibration case.
19. **Engine** — This plate compactor uses a Hatz 1B30E diesel engine. Refer to the owner's manual for engine information.
20. **Front Cover** — Covers the front of the compactor.
21. **Center Cover** — Covers the center of the compactor.
22. **Stopper for Rear Cover** — Holds the rear cover in place.
23. **Rear Cover** — Covers the rear of the compactor.
24. **Vibrating Plate** — A flat, open plate made of durable cast iron construction used in the compacting of soil.
25. **Hook (Lifting Bale)** — When lifting of the compactor is required either by forklift, crane etc., tie rope or chain around this lifting point.

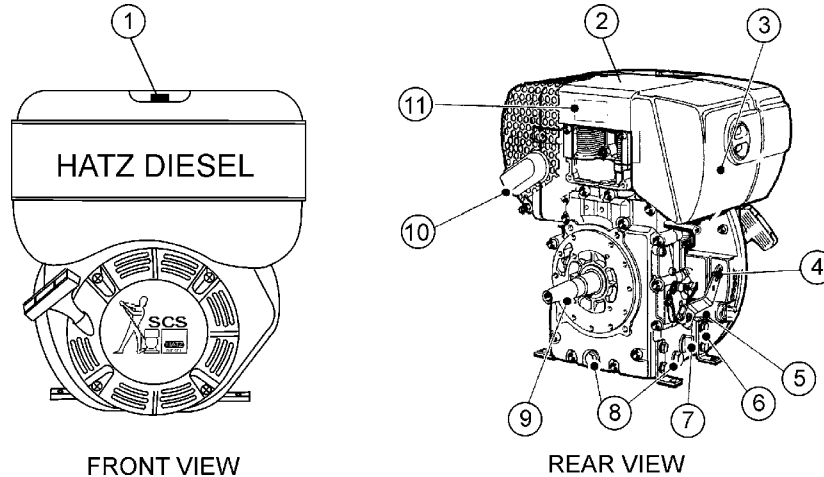

Figure 3. Engine Controls and Components

INITIAL SERVICING

The engine (Figure 3) must be checked for proper lubrication and filled with fuel prior to operation. Refer to the manufacturer's Engine manual for operating and servicing information.

1. **Fuel Filler Cap/Fuel Tank** — Pull this latch to add **diesel** fuel to the tank. After refueling, always make sure the fuel cap is latched properly. **DO NOT** over fill. For additional information refer to engine owner's manual.

DANGER



Adding fuel to the tank should be done only when the engine is stopped and has had an opportunity to cool down. In the event of a fuel spill, **DO NOT** attempt to start the engine until the fuel residue has been completely wiped up, and the area surrounding the engine is dry.

2. **Engine Lifting Straps/Cover** — Remove the air cleaner cover, then lift this cover (the one with decals on it) to gain access to the engine lifting straps.
3. **Air Cleaner/Cover** — Prevents dirt and other debris from entering the fuel system. Remove wing-nut on side of air filter cover to gain access to filter element.
4. **Speed Control Lever** — This lever is connected to the throttle control which is located on the side of the engine compartment cover. Use this lever to control engine speed.
5. **Dipstick** — Remove dipstick to determine if the engine oil level is low. If low, add oil as specified.

6. **Engine Motor Mounts** — Attach these engine mounts to the compactor frame. Tighten securely.
7. **Oil Filter** — Remove this bolt to gain access (internal) to the engine oil filter. Service the oil filter as recommended in the maintenance section of this manual.
8. **Oil Drain Plugs** — There are two oil drain plugs, one is underneath the flywheel, the other on the side of the engine. Remove these plugs to drain engine oil from the engine crankcase.
9. **Crankshaft** — Connect this shaft to the input of the transmission.
10. **Muffler** — Used to reduce noise and emissions.
11. **Nameplate** — Contains information about the engine.

NOTICE

Operating the engine without an air filter, with a damaged air filter, or a filter in need of replacement will allow dirt to enter the engine, causing rapid engine wear.

WARNING



Engine components can generate extreme heat. To prevent burns, **DO NOT** touch these areas while the engine is running or immediately after operating. **NEVER** operate the engine with the muffler removed.

BEFORE STARTING

1. Read all safety instructions at the beginning of manual.
2. Clean the compactor, removing dirt and dust, particularly the engine cooling air inlet, carburetor and air cleaner.
3. Check the air filter for dirt and dust. If air filter is dirty, replace air filter with a new one as required.
4. Check carburetor for external dirt and dust. Clean with dry compressed air.
5. Check fastening nuts and bolts for tightness.

ENGINE OIL CHECK

1. To check the engine oil level, place the compactor on secure level ground with the engine stopped. If the oil level is low, add oil (Grade CC or above).
2. Lubrication is done from the top of the engine (Figure 4).

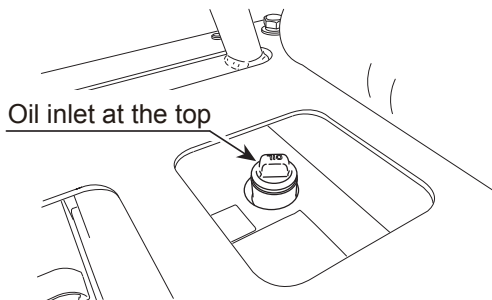

Figure 4. Adding Engine Oil

NOTICE

Pour oil slowly from the top. Oil might overflow if large amount of oil is poured right away.

Table 5. Oil Type

Season	Temperature	Oil Type
Summer	25°C or Higher	SAE 10W-30
Spring/Fall	25°C~10°C	SAE 10W-30/20
Winter	0°C or Lower	SAE 10W-10

DANGER



EXPLOSIVE FUEL!

Motor fuels are highly flammable and can be dangerous if mishandled. **DO NOT** smoke while refueling. **DO NOT** attempt to refuel the compactor if the engine is hot! or running.

FUEL CHECK

1. The fuel tank cap is equipped with a lock lever. Unlock the lever before opening cap (Figure 5).

Lock lever Fuel tank cap

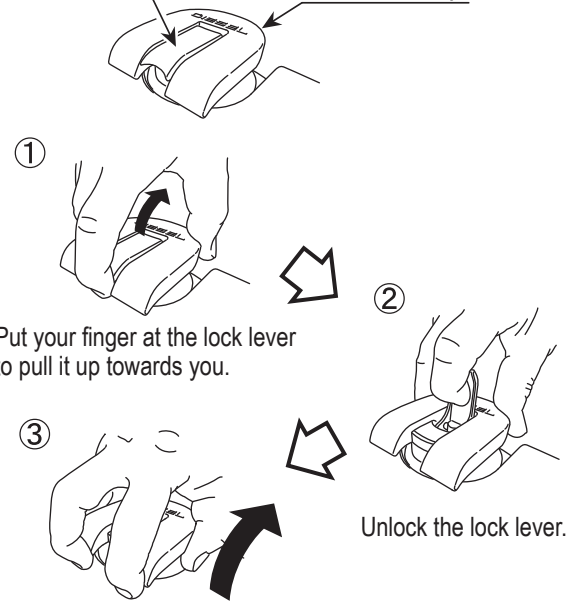

Put your finger at the lock lever to pull it up towards you.

Unlock the lock lever.

Put your fingers to the tabs at the two locations of the tank cap to pull up towards you.

Figure 5. Unlocking Fuel Cap Lever

1. Visually inspect to see if fuel level is low. If fuel is low, replenish with unleaded fuel. Fuel inlet is located under the rubber cover at the front cover top portion.
2. When refueling, be sure to use a strainer for filtration. **DO NOT** top-off fuel. Wipe up any spilled fuel immediately.

V-BELT COVER REMOVAL

To inspect the V-belt, remove the top and bottom belt covers. The V-belt will be as shown in Figure 6.

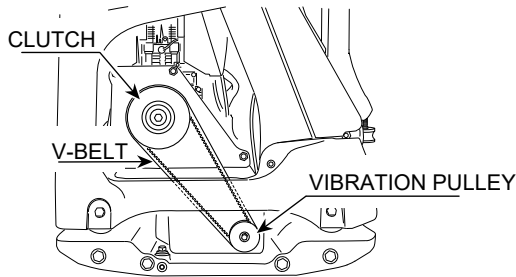

Figure 6. V-Belt Cover Removal

V-BELT INSPECTION

Visually examine the V-belt (Figure 7) and determine if it is full of tiny cracks, frayed, has pieces of rubber missing, is peeling or otherwise damaged.

Also, examine the belt and determine if it is **oil soaked** or **"glazed"** (hard shiny appearance on the sides of the belt). Either of these two conditions can cause the belt to run hot, which can weaken it and increase the danger of it breaking.

If the V-belt exhibits any of the referenced wear conditions replace the V-belt immediately.

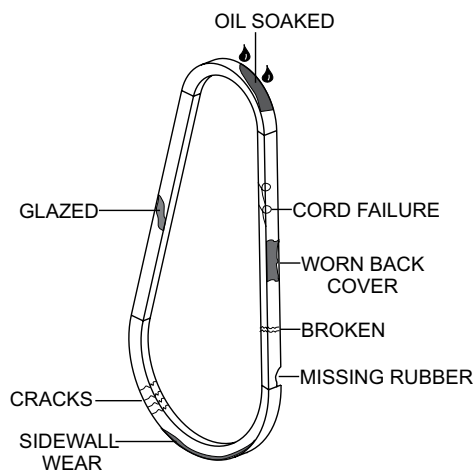

Figure 7. Drive Belt Inspection

V-BELT TENSION

The V-belt tension is proper if the V-belt bends 10 to 15 mm (Figure 8) when depressed with finger at midway between the clutch and vibrator pulleys.

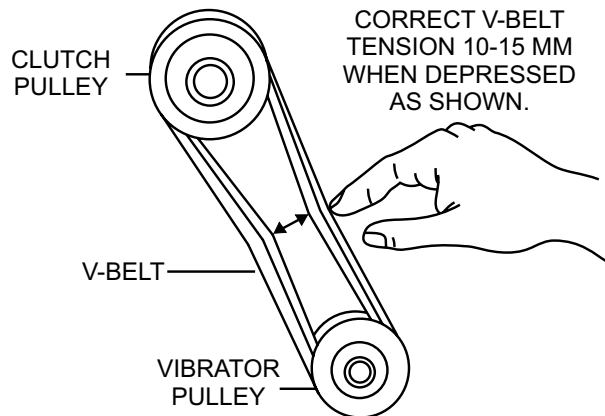

Figure 8. V-Belt Tension

VIBRATOR OIL CHECK

1. Place the plate compactor horizontally on a flat surface. Make sure the compactor is level when checking the oil in the vibrator assembly.
2. Check vibrator oil level by removing the oil plug (vibrator oil gauge) as shown in Figure 9. Clean the oil gauge and re-thread back in. Remove the oil gauge again and confirm oil level does not exceed the cross hash of the oil plug. **DO NOT OVERFILL!**
3. The vibrator holds approximately 20.3 oz. (600 cc). **IMPORTANT**, if oil is required, replace using only SAE 10W-30 motor oil.

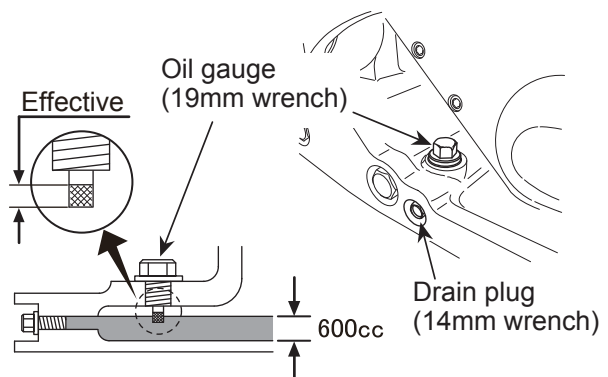

Figure 9. Vibrator Oil Check

HANDLE BAR

The height of the handle bar can be adjusted for ease of use. Adjust the handle height as follows. Refer to Figure 10.

1. Loosen the wing nut.
2. Turn the grip clockwise to raise the handle or counterclockwise to lower the handle.
3. When the handle bar is raised to the desired height, tighten the wing nut.

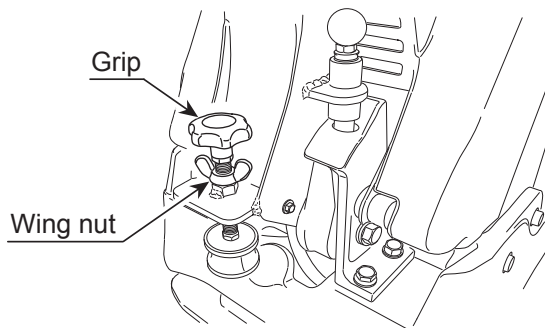



Figure 10. Handle Height Adjustment

CAUTION



DO NOT attempt to operate the compactor until the Safety, General Information and Inspection sections of this manual have been *read and thoroughly understood*.

This section is intended to assist the operator with the initial startup of the compactor. It is extremely important that this section be read carefully before attempting to use the compactor in the field.

STARTING THE ENGINE

Electric Start

1. Insert the key to the key switch.
2. Move the throttle lever (Figure 11) to the **idle** position.

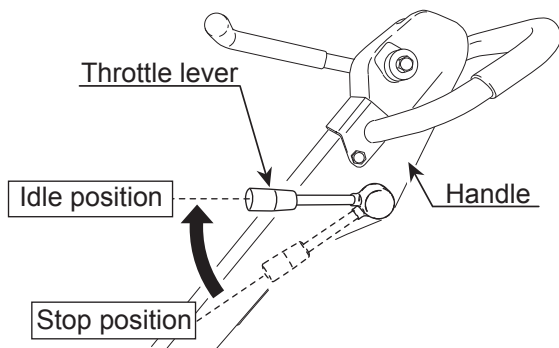

Figure 11. Throttle Lever (Idle Position)

3. Turn the key to the "Run" position (Figure 12). The buzzer sounds.

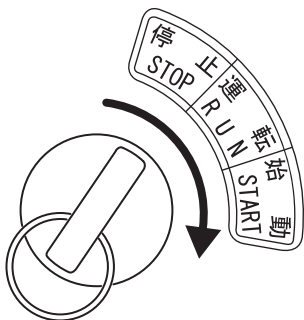
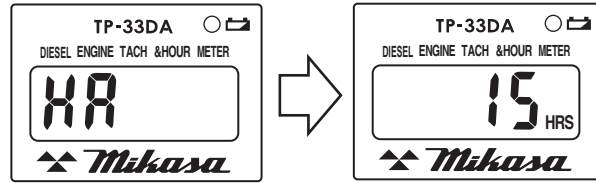

Figure 12. Key Positions

4. After "HA" is displayed on the hour tachometer, the display will change immediately to "cumulative time" (Figure 13).



"HA" is displayed at the operation position, then immediately it will change to "Cumulative time".

Figure 13. Hour Tachometer (Cumulative Time)

5. Turn the key further to the "Start" position to start the engine. When the engine starts, let go of the key. When the engine revolution increases, the buzzer stops.
6. When the engine is in operation, the Hour Tachometer display will show the "rotation number" (Figure 14).

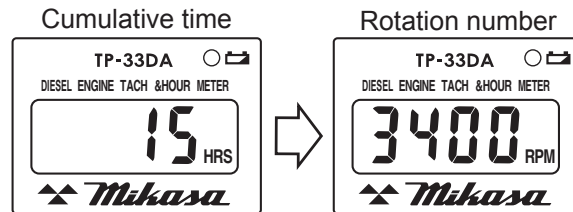

Figure 14. Hour Tachometer (Rotation Number)

7. After the engine has started, warm up the engine at low speed for 2 to 3 minutes, especially in cold weather.

CAUTION

When the engine does not start, do not run the cell motor continuously for more than 5 seconds. Move the key back to the "Run" position then wait about 10 seconds to restart.

While the engine is running, never turn the key switch to the "Start" position.

Recoil Start

1. Insert the key to the key switch.
2. Move the throttle lever (Figure 11) to the *idle* position.
3. Turn the key to the "Run" position (Figure 12). The buzzer sounds.
4. After "HA" is displayed on the hour tachometer, the display will change immediately to "cumulative time".
5. Grasp the starter grip (Figure 15) and slowly pull it out. The resistance becomes the hardest at a certain position, corresponding the compression point. Rewind the rope a little from that point and pull out sharply.

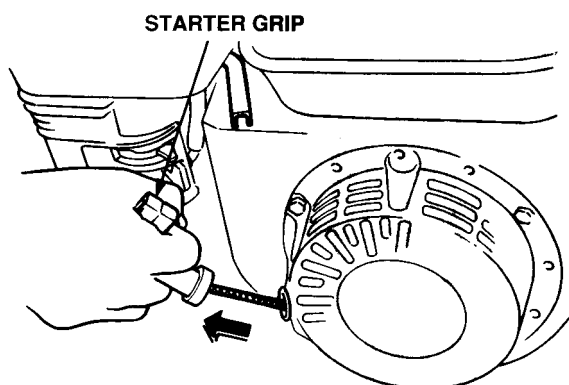

Figure 15. Starter Grip

NOTICE

DO NOT pull the starter rope all the way to the end.

DO NOT release the starter rope after pulling. Allow it to rewind as slow as possible.

6. When engine starts, release the starter grip and allow the rope to recoil.
7. After the engine has started, warm up the engine at low speed for 2 to 3 minutes, especially in cold weather.
8. Before the compactor is placed in to operation, run the engine for several minutes. Check for fuel leaks, and noises that would associate with a lose component.

OPERATION

CAUTION



ALWAYS follow all safety rules in the safety section of this manual before operating compactor. Keep work area clear of debris and other objects that could cause bodily injury or damage to the compactor.

1. Once the engine has started, move the engine throttle lever quickly to the **operation** position (Figure 16).

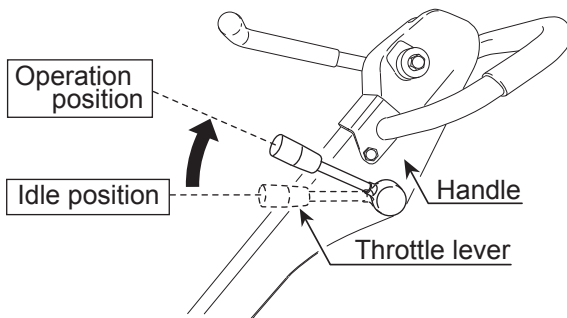

Figure 16. Throttle Lever (Operation Position)

2. With the throttle lever in the run position, the engine speed should be around 2,300 RPM, therefore engaging the centrifugal clutch.

NOTICE

ALWAYS move the throttle lever quickly without hesitation, because increasing the engine speed slowly causes the clutch to slip.

3. The direction control lever allows the machine to be moved either backward or forward (Figure 17). When the direction control lever is pushed forward, the machine moves forward. When pulled backward, the machine moves backward.

NOTICE

Your unit may be equipped with direction control levers on both the right and left side of the handle. Earlier models only have one control lever located on the right side of the handle.

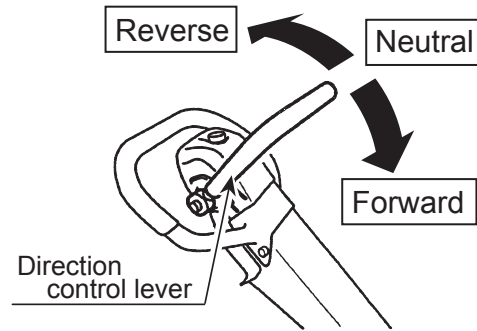

Figure 17. Direction Control Lever

4. When the direction control lever is the neutral position, the machine vibrates staying at the same location

NOTICE

NEVER stop the engine suddenly while working at high speeds.

5. Compactor traveling speed may drop on soils which contain clay, however there may be cases where traveling speed drops because the compaction plate does not leave the ground surface easily due to the composition of the soil. To rectify this problem do the following:
 - Check the bottom plate to see if clay or equivalent material has been lodge in the plate mechanism. If so, wash with water and remove.
 - Remember the compactor does not work as efficiently on clay or soils that have a high moisture content level.
 - If the soil has a high moisture level, dry soil to appropriate moisture content level or carry out compaction twice.

STOPPING THE ENGINE

Normal Shutdown

1. Move the throttle lever to the **idle** position (Figure 18) and run the engine for three minutes at low speed.

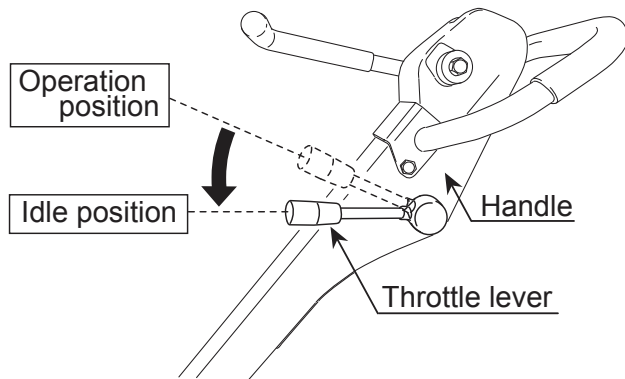

Figure 18. Throttle Lever (Idle)

2. Move the throttle lever (Figure 19) to the "Stop" position to stop the engine. The buzzer will sound.

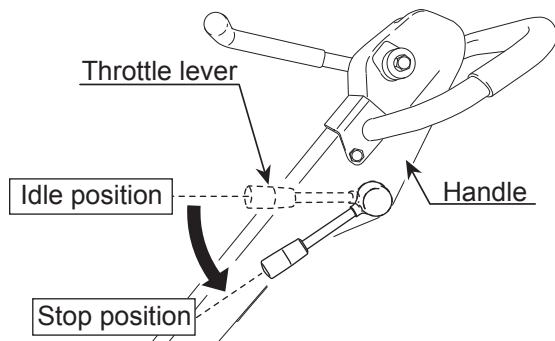

Figure 19. Throttle Lever (Stop Position)

3. Turn the key to the "Stop" position (Figure 20). The buzzer will stop.

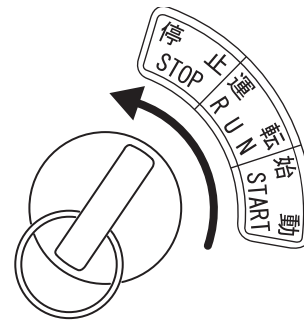

Figure 20. Key Switch (Stop)

Emergency Shutdown

1. Move the throttle lever quickly to the **IDLE** position, and turn the key to the "Stop" position.

GENERAL MAINTENANCE

General maintenance practices are crucial to the performance and longevity of your compactor. This equipment requires routine cleaning, inspection and lubrication. Reference Table 6 and Table 7 for scheduled engine and compactor maintenance.

The following procedures, devoted to maintenance, can prevent serious compactor damage or malfunctioning.

NOTICE

Reference **HATZ** engine manual supplied with your compactor for more detailed engine maintenance and troubleshooting.



CAUTION



ALWAYS allow the engine to cool before servicing. **NEVER** attempt any maintenance work on a hot engine.



WARNING

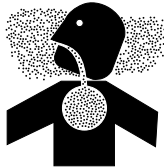

Some maintenance operations may require the engine to be run. Ensure that the maintenance area is well ventilated. Diesel engine exhaust contains poisonous carbon monoxide gas that can cause unconsciousness and may result in **DEATH**.

General Cleanliness

Clean the compactor daily. Remove all dust and debris buildup (mud, clay etc.). If the compactor is steam-cleaned, ensure that lubrication is accomplished **AFTER** steam cleaning.

NOTICE

Inspection and other services should always be carried out on hard and level ground with the engine shutdown.

NOTICE

The inspection intervals listed in the maintenance tables are for operation under normal conditions. Adjust your inspection intervals based on the number hours plate compactor is in use, and particular working conditions.

MAINTENANCE

To make sure your plate compactor is always in good working condition before using, carry out the maintenance inspection in accordance with Table 6 and Table 7.

ENGINE MAINTENANCE

Perform engine maintenance as listed in Table 6.

Table 6. Engine Maintenance Schedule							
Description (3)	Operation	Before	First Month or 10 hrs	Every 3 Months or 25 hrs	Every 6 Months or 50 hrs	Every Year or 100 hrs	Every 2 Years or 200 hrs
Engine Oil	CHECK	X					
	CHANGE		X				
Air Cleaner	CHECK	X					
	CHANGE			X (1)			
All Nuts and Bolts	Re-tighten If Necessary	X					
Cooling Fins	CHECK				X		
Fuel Tank	CLEAN					X	
Fuel Filter	CHECK					X	
Idle Speed	CHECK-ADJUST					X (2)	
Valve Clearance	CHECK-ADJUST						X (2)
Fuel lines	CHECK	Every 2 years (replace if necessary) (2)					

1. Service more frequently when used in **DUSTY** areas.
2. These items should be serviced by your service dealer, unless you have the proper tools and are mechanically proficient. Refer to the **HATZ** Shop Manual for service procedures.
3. For commercial use, log hours of operation to determine proper maintenance intervals.

MACHINE INSPECTION

Perform machine inspection as listed in Table 7.

Interval	Check	Solution
Daily Before Starting	Machine	Clean if necessary.
	Fuel Tank For Leaks	Repair fuel leaks.
	Fuel System for Leaks	Repair fuel leaks.
	Engine Oil	Add oil if necessary.
	Vibrator Oil	Add oil if necessary.
	Air Cleaner Element	Clean/Replace
	Guard Frame	Inspect/deformations
	Shock Absorber	Replace if damaged.
	Hydraulic Pump	Check/Repair Leaks
	Hydraulic Pipe System	Check/Repair leaks, Inspect for wear
	Direction Control Lever	Check bolts/nuts, Inspect for wear
	Duct Hose	Check for crack/damage
Every 20 Hours	Engine Oil/Oil Filter	Replace only after first 20 hrs.
Every 100 Hours	Engine Oil	Change
	Engine Oil Filter	Wash
	Vibrator Oil	Check oil level. Check for leaks/dirt.
	Hydraulic Oil	Check oil level. Check for leaks.
	Battery Terminal	Clean
Every 200 hours	V-Belt	Inspect, replace if damaged or worn.
	Clutch	Inspect, replace if not working properly.
	Engine Bolts	Replace bolts if deformed or elongated.
Every 300 hours	Vibrator Oil	Change
	Fuel Filter	Change
	Hydraulic Oil	Change
	Engine Oil Filter	Change
Every 2 years	Fuel Lines	Replace

TIGHTENING TORQUE

Reference Table 8 below (Tightening Torque), for retightening of nuts and bolts.

Material	6mm	8mm	10mm	12mm	14mm	16mm	18mm	20mm
4T	70	150	300	500	750	1,100	1,400	2,000
6-8T	100	250	500	800	1,300	2,000	2,700	3,800
11T	150	400	800	1,200	2,000	2,900	4,200	5,600
*	100 (6mm) 300 ~ 350 (8mm) 650 ~ 700 (10mm)							
**	In case counter-part is of aluminum							
Bolt threads used with this machine are all right handed								
Material and quality of material is marked on each bolt, and screw.								

ENGINE AIR CLEANER

CAUTION



Wear protective equipment such as approved safety glasses or face shields and dust masks or respirators when cleaning air filters with compressed air.

This engine is equipped with a replaceable, high-density paper air cleaner element. See Figure 21 for air cleaner components.

1. Remove the air cleaner cover and high-density paper air cleaner element (Figure 21).
2. Tap the paper filter element several times on a hard surface to remove dirt, or blow compressed air not exceeding 30 psi (207 kPa, 2.1 kgf/cm²) through the filter element from the inside out. **NEVER** brush off dirt. Brushing will force dirt into the fibers. Replace the paper filter element if it is excessively dirty.

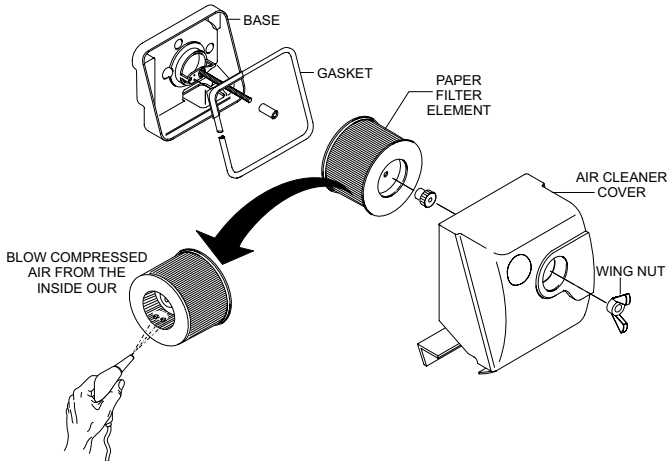

Figure 21. Engine Air Cleaner

NOTICE

Operating the engine with loose or damaged air cleaner components could allow unfiltered air into the engine causing premature wear and failure.

DUST POT

Always clean the dust pot. A clogged dust pot reduces cyclone effect with cleaner element wearing easily.

1. Release locking latch (Figure 22) on dust pot and remove dust pot from air cleaner body.

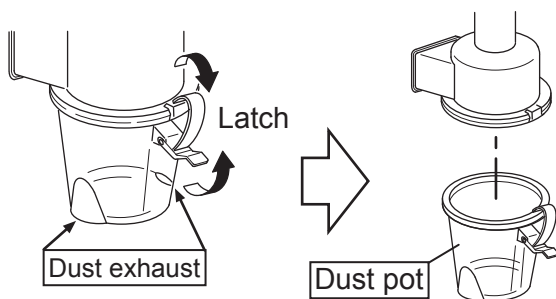

Figure 22. Unlatching Dust Pot

2. Clean dust pot with water and neutral detergent.

3. Reinstall dust pot onto air cleaner body and secure dust pot with locking latches (Figure 23).

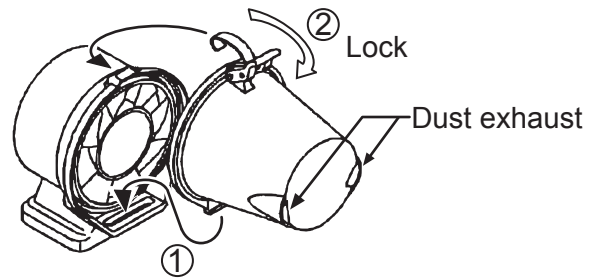

Figure 23. Latching Dust Pot

ENGINE OIL

NOTICE

Drain the engine oil when the oil is warm.

1. Remove the oil drain bolt (Figure 24). and sealing washer and allow the oil to drain into a suitable container.
2. Replace engine oil with recommended type oil as listed in Table 5. For engine oil capacity, see Table 2 (Engine Specifications). **DO NOT** overfill.
3. Reinstall drain bolt with sealing washer and tighten securely.

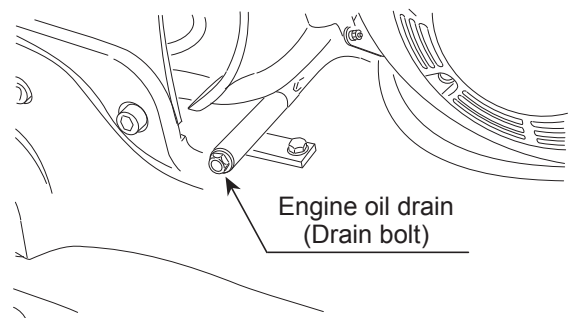

Figure 24. Draining Engine Oil

HYDRAULIC OIL

1. With the handle in vertical position, remove the plug cap from the hydraulic pump (Figure 25).

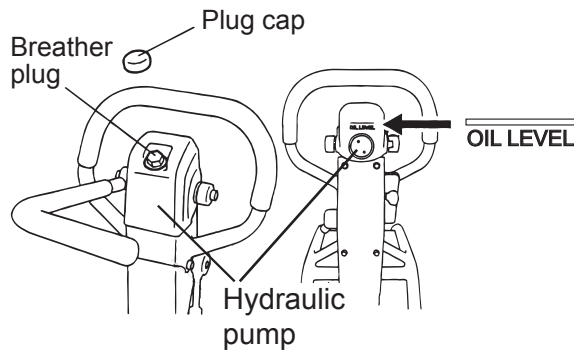

Figure 25. Removing Plug/Breather Cap

2. Remove the breather plug with a 24 mm wrench at the top of the hydraulic pump.
3. Remove the hydraulic hose connected to the cylinder on the vibrator side (Figure 26).

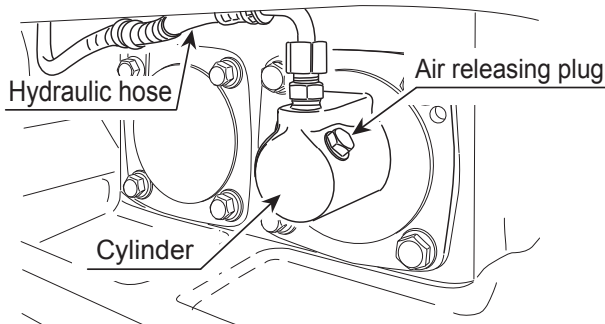

Figure 26. Removing Hydraulic Hose

4. Set the run lever to reverse.
5. Drain the hydraulic oil from the pump.
6. After the oil is drained, attach the hydraulic hose again to the cylinder on the vibrator side.

7. With the direction control lever at the forward-most position, secure the guard frame with a rope to immobilize (Figure 27).

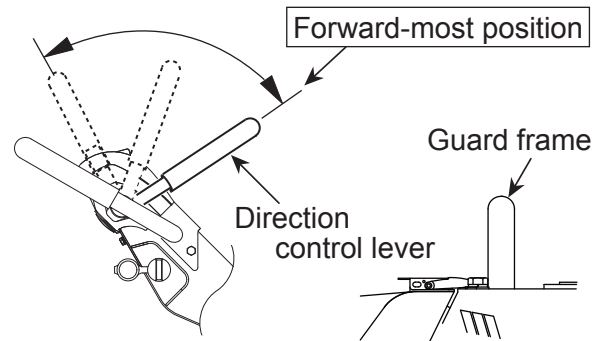

Figure 27. Direction Control Lever (Forward Position)

8. Pour hydraulic oil (550 cc) to the hydraulic pump breather plug attachment hole (Figure 25).
9. Remove the air releasing plug on vibrator cylinder. Oil will then come out from the air releasing plug. After air bubbles stop coming out, reinsert plug. Tighten securely (Figure 26).
10. Release the direction control lever and move the lever forward and reverse several times (until no air bubbles are seen). Keep the lever at the forward position for 10 seconds every time. (Because the check valve is opened at the maximum forward position and air bubble will come out from the oil tank of the hydraulic pump).
11. In case the air bleeding is insufficient, repeat steps 9 and 10.
12. Attach the hydraulic pump breather plug and put on the plug cap. After making sure the hydraulic oil in the pump is at OIL LEVEL, attach the breather plug.

CAUTION

Do not exceed OIL LEVEL of hydraulic oil. If the level is higher, oil will burst out from the breather plug.

V-BELT

Visually examine the V-belt (Figure 28) and determine if it is full of tiny cracks, frayed, has pieces of rubber missing, is peeling or otherwise damaged.

Also, examine the belt and determine if it is **oil soaked** or **"glazed"** (hard shiny appearance on the sides of the belt). Either of these two conditions can cause the belt to run hot, which can weaken it and increase the danger of it breaking.

If the V-belt exhibits any of the above wear conditions replace the V-belt immediately.

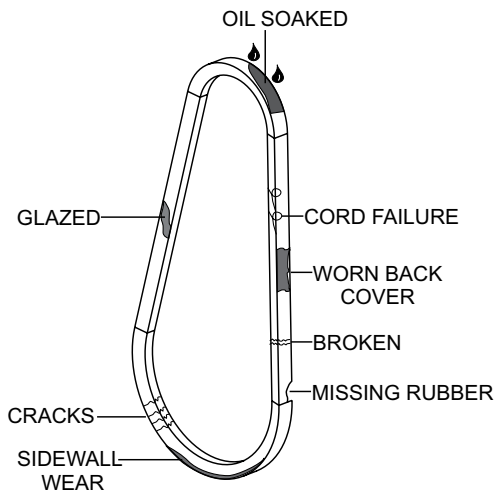

Figure 28. V-Belt Inspection

BATTERY

The standard battery installed is a maintenance-free battery. It is not necessary to supply battery fluid. In case of a sudden voltage drop, the battery cannot be charged quickly, so it has to be replaced with a new one.

Checking Battery Capacity

1. Check the battery checker on the hour tachometer (Figure 29).

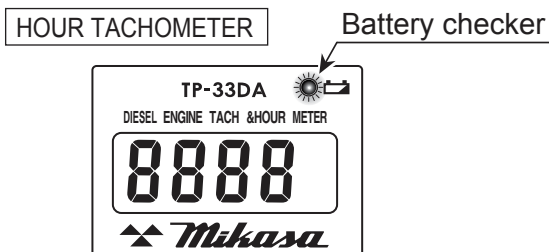

Figure 29. Battery Check

2. When the battery charge gets low, the battery checker lights red.

NOTICE

If an old battery is used, even when the battery checker is not lighted (indicating low charge), the cell starter might not operate because of low charging level. If that happens, change the battery with the new one.

Changing the Battery

1. Unlatch the two stoppers at the top portion of the rear cover to open the rear cover (Figure 30).

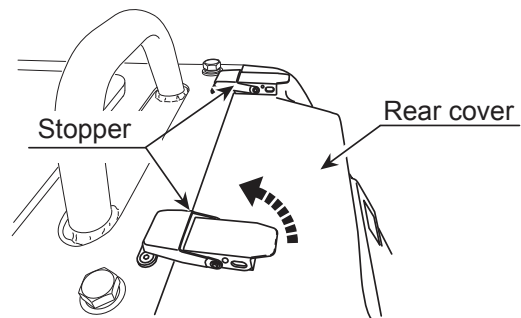

Figure 30. Opening Rear Cover

2. Loosen the two bolts on each side of the bar connecting the battery to the side rails (Figure 31).

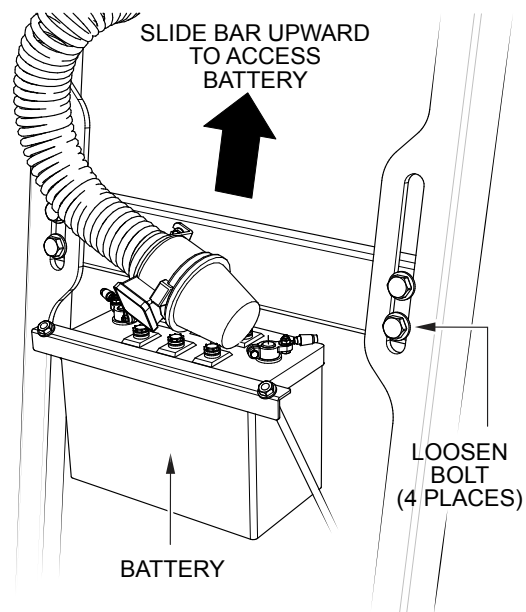

Figure 31. Raising The Battery

3. Slide the bar up the notches for easy access to the battery and tighten the bolts.
4. Take off the nuts and remove the battery holder (Figure 32).
5. After tilting the battery backward, disconnect the battery terminal. Always disconnect the black terminal on the negative side first.
6. Pull up the handle on the top of the battery to remove the battery from the machine (Figure 32). Make sure that the battery terminals do not touch the frame.

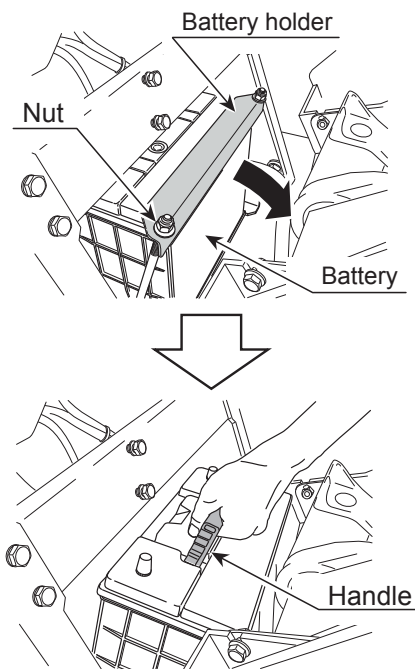

Figure 32. Removing Battery

7. To install new battery, perform the procedure in reverse. Make sure that the red terminal (positive side) is connected first.
8. Loosen the two bolts on each side of the battery bracket and slide the bracket down to lower the battery to its original location.
9. Tighten the four bolts.

STORAGE

1. Wash off dirt and soil from every part with water. While washing, be careful not to let the water splash on the electric components such as the battery and the engine muffler.
2. Cover the machine to prevent dust and dirt buildup.
3. Store the machine in a dry area away from direct sunlight.
4. Do not leave the machine outdoors. Keep it indoors.
5. When not used for a long period of time, drain the fuel from the fuel tank, and either disconnect the battery terminals or remove the battery itself.
6. When the machine is used after a long storage period, check the level of engine oil and battery capacity before using.

TROUBLESHOOTING (COMPACTOR)

Troubleshooting (Compactor)		
Symptom	Possible Problem	Solution
Travel speed low and vibration weak.	Clutch slips?	Adjust or replace clutch.
	V-belt slips?	Adjust or replace V-belt.
	Excessive oil in vibrator?	Fill to correct level.
	Trouble in vibrator internals?	Check vibrator assembly for any worn or defective parts, replace any defective parts.
	Aeration in hydraulic oil for for travel reversing system?	Purge air in hydraulic oil. (Bleed plug)
	Engine speed incorrect?	Set engine speed to correct RPM.
Travels forward or backward but unable to switch direction.	Hydraulic pump problems?	Check hydraulic pump.
	Direction Control Lever installation wrong?	Correct installation of IDirection Control Lever.
	Broken or defective oil hose?	Replace oil hose.
	Aeration in hydraulic oil?	Purge air in hydraulic oil. (Bleed plug)
	Excessive oil in reversing system?	Fill to correct level.
	Hydraulic pump clogged with trash?	Clean valve inside hydraulic pump.
	Cylinder piston bearing failure?	Check piston bearing in cylinder for leakage.
Does not travel in forward or reverse	V-belt disengaged or slips?	Engage V-belt, adjust or replace.
	Clutch slips?	Adjust clutch, replace if necessary.
	Vibrator locks?	Check vibrator and correct problem.
	Cylinder piston bearing failure?	Check piston bearing in cylinder for leakage at USH packing.
Direction Control Lever operating resistance for reverse is high.	Piston inside hydraulic pump not moving smoothly?	Adjust or replace.
	Vibrator cylinder piston does not move smoothly	Adjust or replace.

TROUBLESHOOTING (ENGINE)

Troubleshooting (Engine)		
Symptom	Possible Problem	Solution
Engine will not start or start is delayed, although engine can be turned over.	No fuel reaching injection pump?	Add fuel. Check entire fuel system.
	Defective fuel pump?	Replace fuel pump.
	Fuel filter clogged?	Replace fuel filter and clean tank.
	Faulty fuel supply line?	Replace or repair fuel line.
	Compression too low?	Check piston, cylinder and valves. Adjust or repair per engine repair manual.
	Fuel pump not working correctly?	Repair or replace fuel pump.
	Oil pressure too low?	Check engine oil pressure.
	Low starting temperature limit exceeded?	Comply with cold starting instructions and proper oil viscosity.
	Defective battery?	Charge or replace battery.
	Air or water mixed in fuel system?	Check carefully for loosened fuel line coupling, loose cap nut, etc.
At low temperatures engine will not start.	Engine oil too thick?	Refill engine crankcase with correct type of oil for winter environment.
	Defective battery?	Replace battery.
Engine fires but stops as soon as starter is switched off.	Fuel filter blocked?	Replace fuel filter.
	Fuel supply blocked?	Check the entire fuel system.
	Defective fuel pump?	Replace fuel pump.
Engine stops by itself during normal operation.	Fuel tank empty?	Add fuel.
	Fuel filter blocked?	Replace fuel filter.
	Defective fuel pump?	Replace fuel pump.
	Mechanical oil pressure shutdown sensor stops the engine due to low oil?	Add oil. Replace low oil shutdown sensor if necessary.
Low engine power, output and speed.	Fuel tank empty?	Add fuel.
	Fuel filter clogged?	Replace fuel filter.
	Fuel tank venting is inadequate?	Ensure tank is adequately vented.
	Leaks at pipe unions?	Check threaded pipe unions. Tape and tighten unions as required.
	Speed control lever does not remain in selected position?	See engine manual for corrective action.
	Engine oil level too full?	Correct engine oil level.
	Injection pump wear?	Use No. 2-D diesel fuel only. Check the fuel injection pump element and delivery valve assembly and replace as necessary.

TROUBLESHOOTING (ENGINE)

Troubleshooting (Engine) - continued		
Symptom	Possible Problem	Solution
Low engine power output and low speed, black exhaust smoke.	Air filter blocked?	Clean or replace air filter.
	Incorrect valve clearances?	Adjust valves per engine specification.
	Malfunction at injector?	See engine manual.
Engine overheats.	Too much oil in engine crankcase?	Drain off engine oil down to upper mark on dipstick.
	Entire cooling air system contaminated or blocked?	Clean cooling air system and cooling fin areas.
	Fan belt broken or elongated?	Change belt or adjust belt tension.
	Coolant insufficient?	Replenish coolant.
	Radiator net or radiator fin clogged with dust?	Clean net or fin carefully.
	Fan, radiator, or radiator cap defective?	Replace defective part.
	Thermostat defective?	Check thermostat and replace if necessary.
Head gasket defective or water leakage?	Replace parts.	

WIRING DIAGRAM

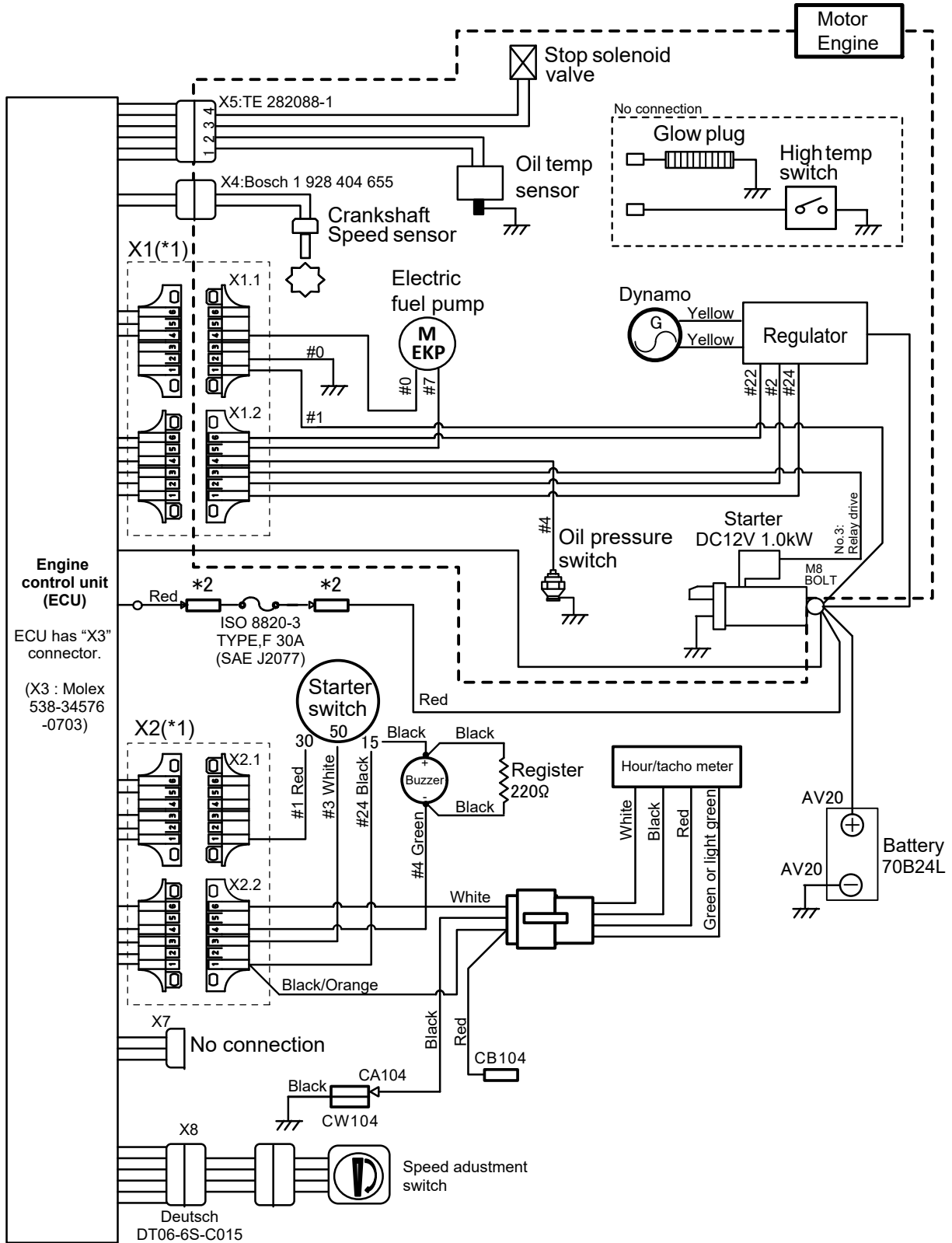

*1 About the model of X1,X2 connectors:
 Male : ITT-CANON 391-8530-006
 Female : ITT-CANON 391-8531-016

*2 About connectors:
 Male : NIHON TANSI 18044-2
 Female : NIHON TANSI 17075-2

OPERATION MANUAL

HERE'S HOW TO GET HELP

PLEASE HAVE THE MODEL AND SERIAL
NUMBER ON-HAND WHEN CALLING

UNITED STATES

Multiquip Inc.

(310) 537- 3700
6141 Katella Avenue Suite 200
Cypress, CA 90630
E-MAIL: mq@multiquip.com
WEBSITE: www.multiquip.com

CANADA

Multiquip

(450) 625-2244
4110 Industriel Boul.
Laval, Quebec, Canada H7L 6V3
E-MAIL: infocanada@multiquip.com

UNITED KINGDOM

Multiquip (UK) Limited Head Office

0161 339 2223
Unit 2, Northpoint Industrial Estate,
Globe Lane,
Dukinfield, Cheshire SK16 4UJ
E-MAIL: sales@multiquip.co.uk

© COPYRIGHT 2022, MULTIQUIP INC.

Multiquip Inc, the MQ logo are registered trademarks of Multiquip Inc. and may not be used, reproduced, or altered without written permission. All other trademarks are the property of their respective owners and used with permission.

This manual MUST accompany the equipment at all times. This manual is considered a permanent part of the equipment and should remain with the unit if resold.

The information and specifications included in this publication were in effect at the time of approval for printing. Illustrations, descriptions, references and technical data contained in this manual are for guidance only and may not be considered as binding. Multiquip Inc. reserves the right to discontinue or change specifications, design or the information published in this publication at any time without notice and without incurring any obligations.

Your Local Dealer is:

