

PARTS MANUAL



Mikasa SERIES
MODEL MVH308GH
REVERSIBLE PLATE COMPACTOR
(HONDA GX270UT2SMXC/GX270UT2SCM
GASOLINE ENGINES)

Revision #12 (08/01/22)

To find the latest revision of this publication or associated operation manual, visit our website at: www.multiquip.com



THIS MANUAL MUST ACCOMPANY THE EQUIPMENT AT ALL TIMES.

TABLE OF CONTENTS

MVH308GH Reversible Plate Compactor

Table Of Contents.....	2
Explanation Of Code In Remarks Column.....	4
Suggested Spare Parts	5

Compactor Component Drawings

Nameplate And Decal Assembly.....	6-7
Vibrating Plate Assembly.....	8-9
Vibrator Assembly	10-13
Base And Engine Assembly	14-17
Electrical Device Assembly	18-19
Control Assembly	20-23
Hydraulic Hand Pump Assembly.....	24-25

Honda GX270UT2SMXC/ GX270UT2SCM Engine Component Drawings

Cylinder Head Assembly	26-27
Cylinder Barrel Assembly	28-29
Crankcase Cover Assembly	30-31
Crankshaft Assembly.....	32-33
Piston Assembly	34-35
Camshaft Assembly.....	36-37
Recoil Starter Assembly	38-39
Fan Cover Assembly.....	40-41
Carburetor Assembly	42-43
Air Cleaner Assembly (GX270UT2SMXC)	44-45
Air Cleaner Assembly (GX270UT2SCM).....	46-47
Muffler Assembly	48-49
Fuel Tank Assembly.....	50-51
Flywheel Assembly	52-53
Ignition Coil Assembly	54-55
Control Assembly	56-57
Engine Decal Assembly.....	58-59

NOTICE

Specifications and part numbers are subject to change without notice.

EXPLANATION OF CODE IN REMARKS COLUMN

The following section explains the different symbols and remarks used in the Parts section of this manual. Use the help numbers found on the back page of the manual if there are any questions.

NOTICE

The contents and part numbers listed in the parts section are subject to change **without notice**. Multiquip does not guarantee the availability of the parts listed.

SAMPLE PARTS LIST

NO.	PART NO.	PART NAME	QTY.	REMARKS
1	12345	BOLT	1	INCLUDES ITEMS W/%
2%		WASHER, 1/4 IN.		NOT SOLD SEPARATELY
2%	12347	WASHER, 3/8 IN. ...	1	MQ-45T ONLY
3	12348	HOSE	A/R	MAKE LOCALLY
4	12349	BEARING	1	S/N 2345B AND ABOVE

NO. Column

Unique Symbols — All items with same unique symbol (@, #, +, %, or >) in the number column belong to the same assembly or kit, which is indicated by a note in the “Remarks” column.

Duplicate Item Numbers — Duplicate numbers indicate multiple part numbers, which are in effect for the same general item, such as different size saw blade guards in use or a part that has been updated on newer versions of the same machine.

NOTICE

When ordering a part that has more than one item number listed, check the remarks column for help in determining the proper part to order.

PART NO. Column

Numbers Used — Part numbers can be indicated by a number, a blank entry, or TBD.

TBD (To Be Determined) is generally used to show a part that has not been assigned a formal part number at the time of publication.

A blank entry generally indicates that the item is not sold separately or is not sold by Multiquip. Other entries will be clarified in the “Remarks” Column.

QTY. Column

Numbers Used — Item quantity can be indicated by a number, a blank entry, or A/R.

A/R (As Required) is generally used for hoses or other parts that are sold in bulk and cut to length.

A blank entry generally indicates that the item is not sold separately. Other entries will be clarified in the “Remarks” Column.

REMARKS Column

Some of the most common notes found in the “Remarks” Column are listed below. Other additional notes needed to describe the item can also be shown.

Assembly/Kit — All items on the parts list with the same unique symbol will be included when this item is purchased.

Indicated by:

“INCLUDES ITEMS W/(unique symbol)”

Serial Number Break — Used to list an effective serial number range where a particular part is used.

Indicated by:

“S/N XXXXX AND BELOW”

“S/N XXXX AND ABOVE”

“S/N XXXX TO S/N XXX”

Specific Model Number Use — Indicates that the part is used only with the specific model number or model number variant listed. It can also be used to show a part is NOT used on a specific model or model number variant.

Indicated by:

“XXXXX ONLY”

“NOT USED ON XXXX”

“Make/Obtain Locally” — Indicates that the part can be purchased at any hardware shop or made out of available items. Examples include battery cables, shims, and certain washers and nuts.

“Not Sold Separately” — Indicates that an item cannot be purchased as a separate item and is either part of an assembly/kit that can be purchased, or is not available for sale through Multiquip.

SUGGESTED SPARE PARTS

MVH308GH PLATE COMPACTOR

1 to 3 units

Qty.	P/N	Description
4	939010260	SHOCK ABSORBER
4	939010010	SHOCK ABSORB STOP
2	070220453	V-BELT
1	956100069	THROTTLE WIRE

NOTICE

Part numbers on this Suggested Spare Parts list may supersede/replace the part numbers shown in the following parts lists.

HONDA GX270UT2SMXC/GX270UT2SCM ENGINES

1 to 3 units

Qty.	P/N	Description
3◆	0650140480	SPARK PLUG, (BPR6ES)
3◇	9807956846	SPARK PLUG, (BPR6ES)
1	28462ZE2W11	ROPE, RECOIL STARTER
3◆	17210ZE3505	ELEMENT, AIR CLEANER
3◇	17210Z1C781	ELEMENT, AIR CLEANER
3◆	17218ZE3505	FILTER OUTER
3◇	17218Z1C780	FILTER OUTER
1	17620Z4H900	CAP, FUEL TANK
1	17672Z4H000	FUEL FILTER, FUEL TANK

NOTICE

- ◆ GX270UT2SMXC
- ◇ GX270UT2SCM

NAMEPLATE AND DECAL ASSY.

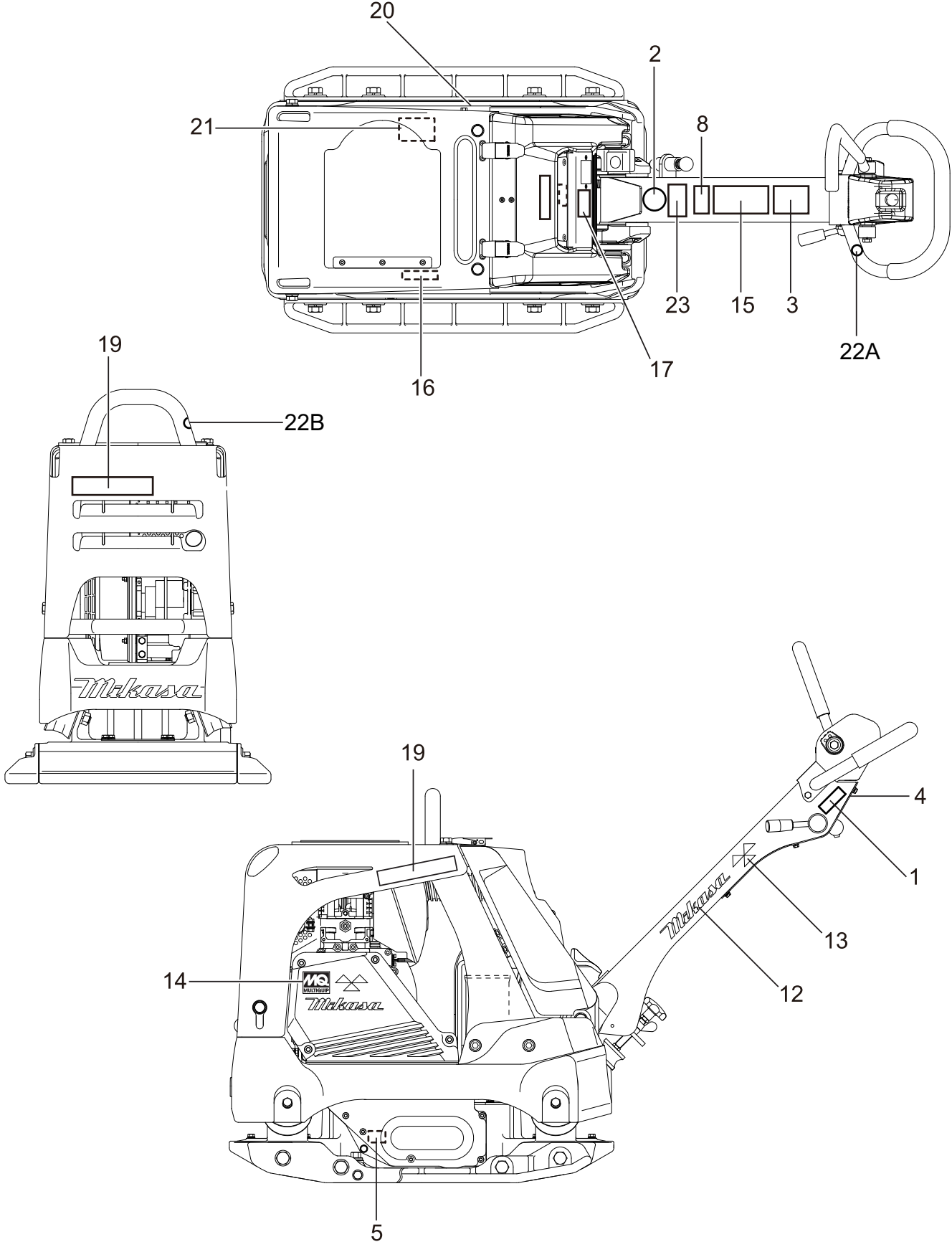

NAMEPLATE AND DECAL ASSY.

<u>NO.</u>	<u>PART NO.</u>	<u>PART NAME</u>	<u>QTY.</u>	<u>REMARKS</u>
1	920204580	DECAL: FULL THROTTLE	1	
2	920203330	EAR PROTECTION LABEL	1	
3	920211060	DECAL: CAUTION (LEVER)	1	
4	920211090	DECAL: SHELL TELLUS OIL 32	1	
5	920201950	DECAL: OIL SAE 10W-30	1	
8	920214100	DECAL: E/G FIRE WARNING	1	
12	920217130	DECAL: MIKASA MARK (W) 200L	2	
13	920217110	DECAL: MIKASA MARK 35X70	2	
14	920201580	DECAL: MQ MARK 71X55	1	
15	920218390	DECAL: CAUTION	1	
16	920205860	DECAL: V-BELT HDPF-5450	1	
17	920218130	DECAL: E/G RPM 3600	1	
19	920217730	DECAL: MODEL (R, OR)	2	
20	920217740	DECAL: MODEL (L, OR)	1	
21		PLATE: SERIAL NO.	1CONTACT MQ PARTS DEPT.
22A	920900090	DECAL, SET, DO NOT LIFT	1	
22B	920900090	DECAL, SET, LIFTING POSITION	1	
23	920222240	DECAL, WARNING PROPOSITION 65	1	

VIBRATING PLATE ASSY.

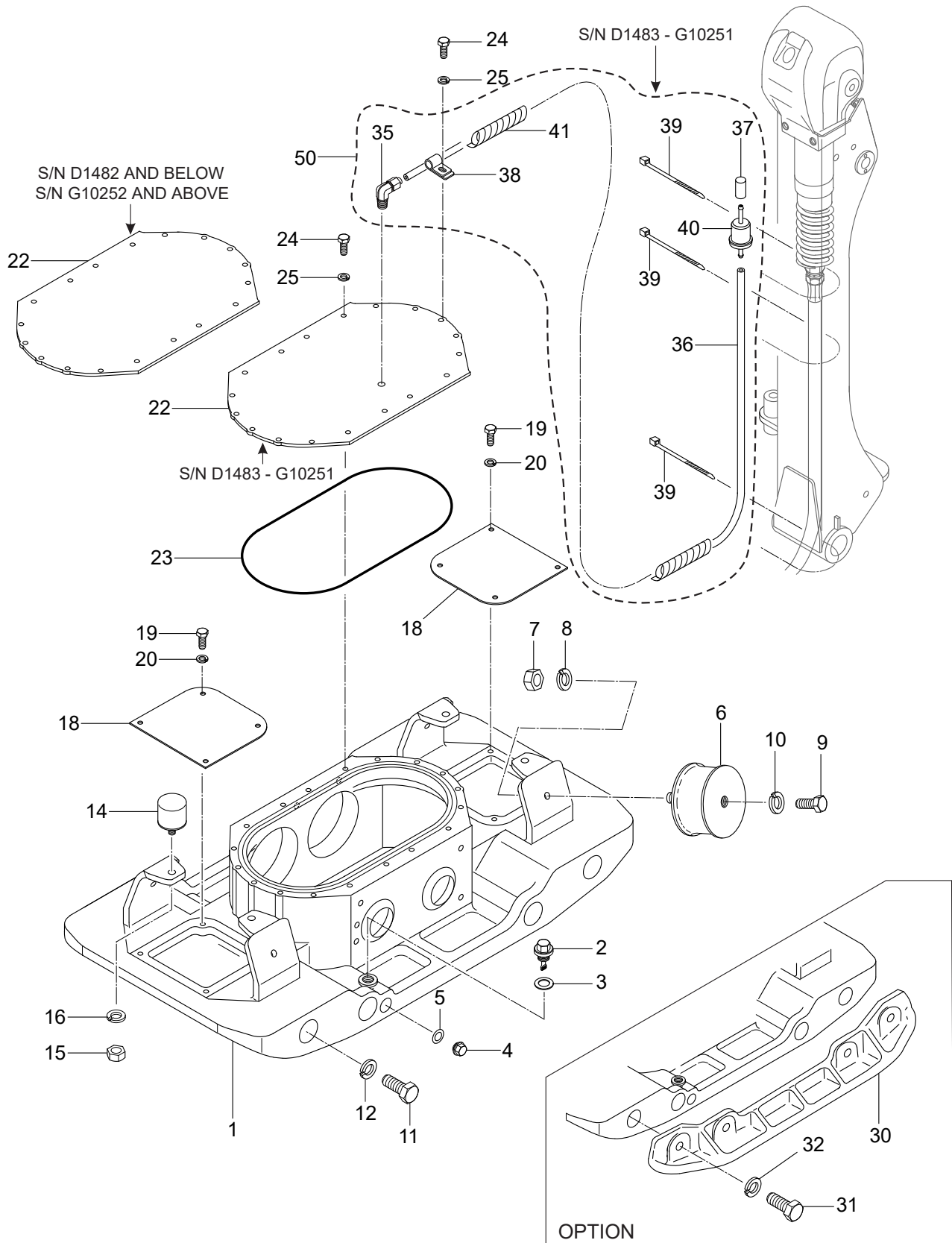

VIBRATING PLATE ASSY.

<u>NO.</u>	<u>PART NO.</u>	<u>PART NAME</u>	<u>QTY.</u>	<u>REMARKS</u>
1	467121091	VIBRATING PLATE	1	
2	465460670	OIL GAUGE	1	
3	953402930	COPPER PACKING	1	
4	953400270	PLUG 1/4X14	1	
5	953405260	PACKING 1/4	1	
6	939010260	SHOCK ABSORBER	4	
7	020316130	NUT M16	4	
8	030216400	WASHER, LOCK M16	4	
9	001221635	BOLT 16X35	4	
10	030216400	WASHER, LOCK M16	4	
11	001221830	BOLT 18X30	8	
12	58407	WASHER, LOCK M18	8.....	REPLACES P/N 030218460
14	939010010	SHOCK ABSORBER, STOPPER	4	
15	020310080	NUT M10	4	
16	030210250	WASHER, LOCK M10	4	
18	467351780	COVER, VIBRATING PLATE	2	
19	014208020	BOLT 8X20.....	8.....	REPLACES P/N 001220820
20	030208200	WASHER, LOCK M8	8	
22	467351790	COVER, VIBRATOR	1.....	S/N 1482 AND BELOW
22	467355940	COVER, VIBRATOR, BREATHER	1.....	S/N 1483 - G10251
22	467351790	COVER, VIBRATOR.....	1.....	S/N G10252 AND ABOVE
23	050103250	O-RING	1	
24	014208020	BOLT 8X20	18.....	REPLACES P/N 001220820
25	030208200	WASHER, LOCK M8	18	
30	467219050	EXTENSION PLATE	2	
31	012218050	BOLT 18X50.....	8.....	REPLACES P/N 001221850
32	58407	WASHER, LOCK M18	8.....	REPLACES P/N 030218460
35#	954410070	90° ELBOW.....	1.....	S/N D1483 - G10251
36#	959029209	TUBE, NYLON.....	1.....	S/N D1483 - G10251
37#	467471710	ELEMENT, BREATHER	1.....	S/N D1483 - G10251
38#	959408920	CLIP, M8.....	1.....	S/N D1483 - G10251
39#	507010110	CLAMP.....	3.....	S/N D1483 - G10251
40#	16910GB2005	FUEL FILTER, IN-LINE	1.....	S/N D1483 - G10251
41#	959021818	SPRIAL TUBE.....	1.....	S/N D1483 - G10251
50	467910040	AIR BREATHER TUBE	1.....	INCLUDES ITEMS W/# S/N D1483 - G10251

VIBRATOR ASSY.

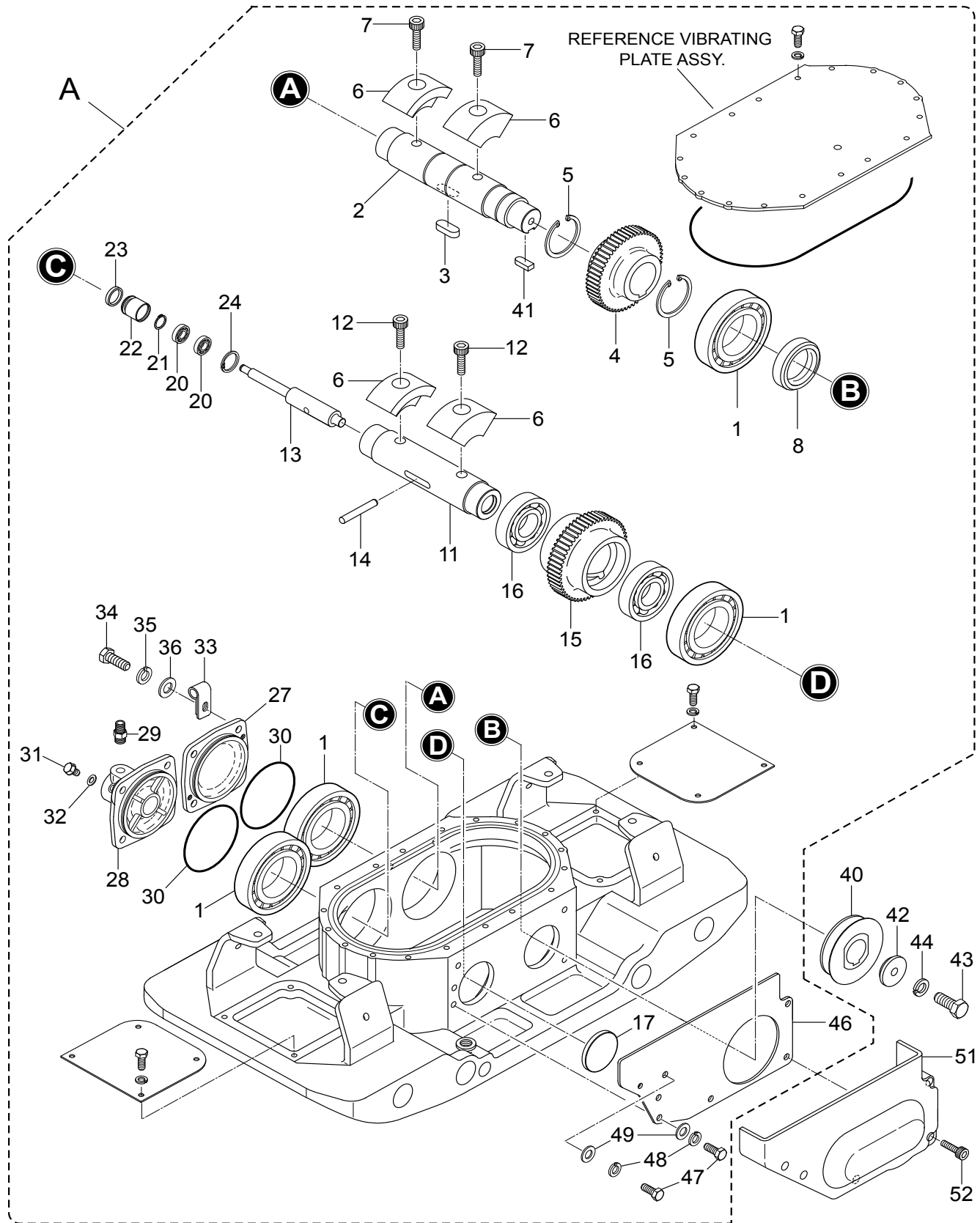

VIBRATOR ASSY.

<u>NO.</u>	<u>PART NO.</u>	<u>PART NAME</u>	<u>QTY.</u>	<u>REMARKS</u>
A	467910030	VIBRATING PLATE ASSY.....	1.....	INCLUDES ITEMS W/# S/N D1482 AND BELOW
A	467910031	VIBRATING PLATE ASSY.....	1.....	INCLUDES ITEMS W/% S/N D1483 - G10251
A	467910032	VIBRATING PLATE ASSY.....	1.....	INCLUDES ITEMS W/\$ S/N G10252 AND ABOVE
1#%\$	047920120	ROLLER BEARING	4	
2#	456331060	ROTARY SHAFT, DRIVE	1.....	S/N D1482 AND BELOW
2%	467355910	ROTARY SHAFT, DRIVE	1.....	S/N D1483 - G10251
2%\$	467910070	ROTARY SHAFT, DRIVE	1.....	S/N G10252 AND ABOVE
3#%\$	951405370	KEY 15X10X39	1	
4#%\$	456327150	GEAR, DRIVE	1	
5#%\$	080200550	STOP RING	2	
6#%\$	464343700	ECCENTRIC ROTATOR	4	
7#%\$	009120301	SOCKET HEAD BOLT 16X40	2	
8#	060105030	OIL SEAL	1.....	S/N D1482 AND BELOW
8%\$	060405040	OIL SEAL	1.....	S/N D1483 AND ABOVE
11#%\$	456337670	ROTARY SHAFT, DRIVEN	1	
12#%\$	009120302	SOCKET HEAD BOLT 16X30	2	
13#%\$	456337380	PISTON ROD	1	
14#%\$	456010010	KNOCK PIN 10X70	1	
15#%\$	467351910	GEAR, DRIVEN	1	
16#%\$	040006911	BEARING	2	
17#%\$	953010030	SEAL CAP	1	
20#%\$	042506000	BEARING	2	
21#%\$	0080000010	STOP RING	1.....	REPLACES P/N 080200100
22#%\$	455435051	PISTON	1	
23#%\$	455010070	PACKING	1	
24#%\$	080100260	STOP RING	1	
27#%\$	467352540	BEARING COVER	1	
28#%\$	467219070	CYLINDER (R)	1	
29#%\$	954010020	CONNECTOR PT, PF1/4	1	
30#%\$	050101050	O-RING	2	
31#%\$	001720812	FLANGE BOLT 8X12	1	
32#%\$	953404600	COPPER PACKING 8X16X2	1	
33#%\$	959408880	CLIP	1	
34#%\$	0105091025	BOLT 10X25.....	8.....	REPLACES P/N 001221025
35#%\$	030210250	WASHER, LOCK M10	8	
36#%\$	031110160	WASHER, FLAT M10	8	
40	467351940	VIBRATING PULLEY	1	
41#%\$	951404970	KEY 12X8X30 R	1	
42	464457370	WASHER	1.....	S/N G10251 AND BELOW
42	467474690	WASHER	1.....	S/N G10252 AND ABOVE
43	012012030	BOLT 12X30.....	1.....	REPLACES P/N 001221230
44	030212300	WASHER, LOCK M12	1	
46#%\$	467351920	GUIDE, BELT COVER	1	

VIBRATOR ASSY. (CONT'D.)

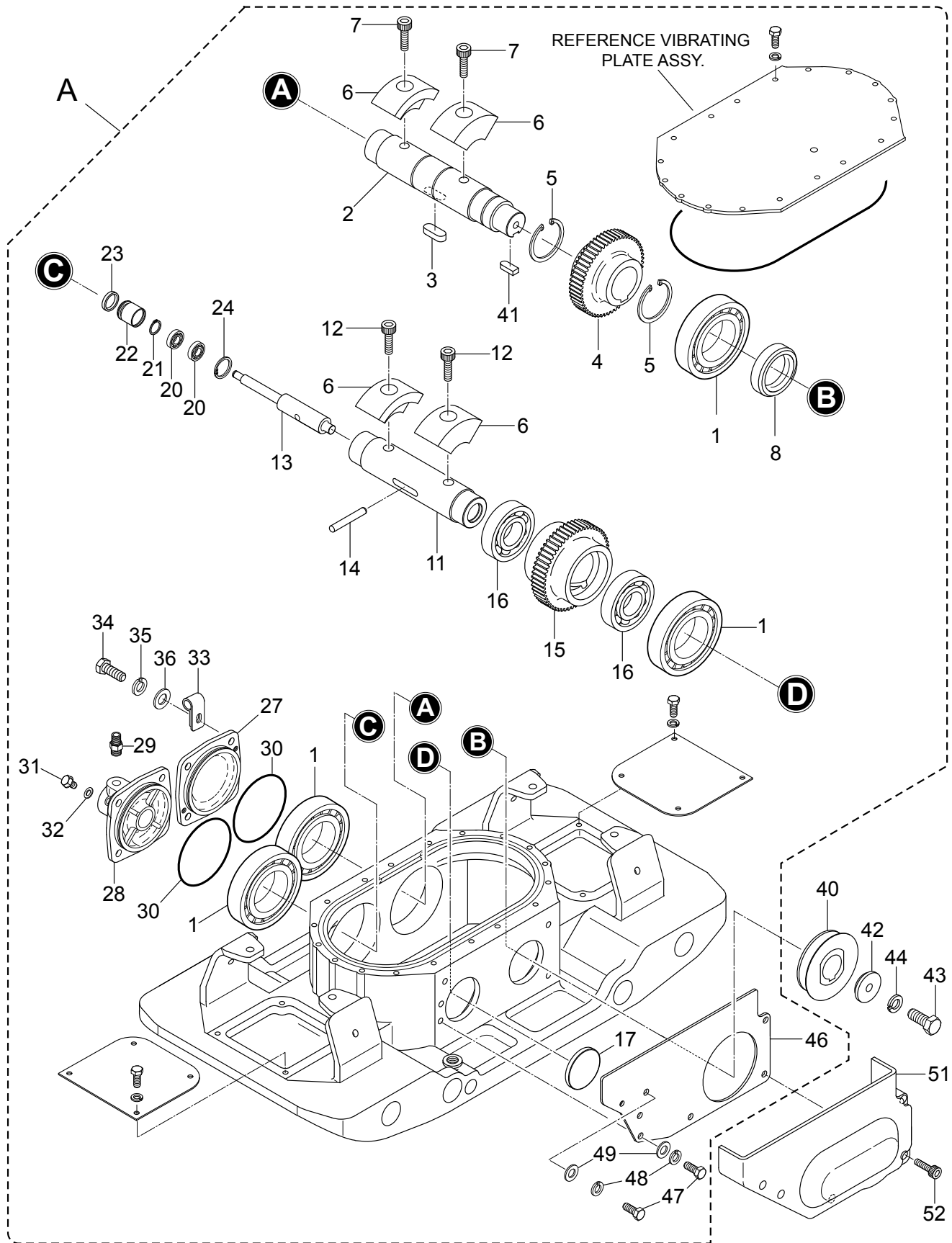

VIBRATOR ASSY. (CONT'D.)

<u>NO.</u>	<u>PART NO.</u>	<u>PART NAME</u>	<u>QTY.</u>	<u>REMARKS</u>
47#%\$	014208020	BOLT 8X20	2.....	REPLACES P/N 001220820
48#%\$	030208200	WASHER, LOCK M8	2	
49#%\$	0401450080	WASHER, FLAT M8	2.....	REPLACES P/N 031108160
51	467218890	BELT COVER, LOWER	1	
52	001520852	SOCKET HEAD BOLT 8X60	5	

BASE AND ENGINE ASSY.

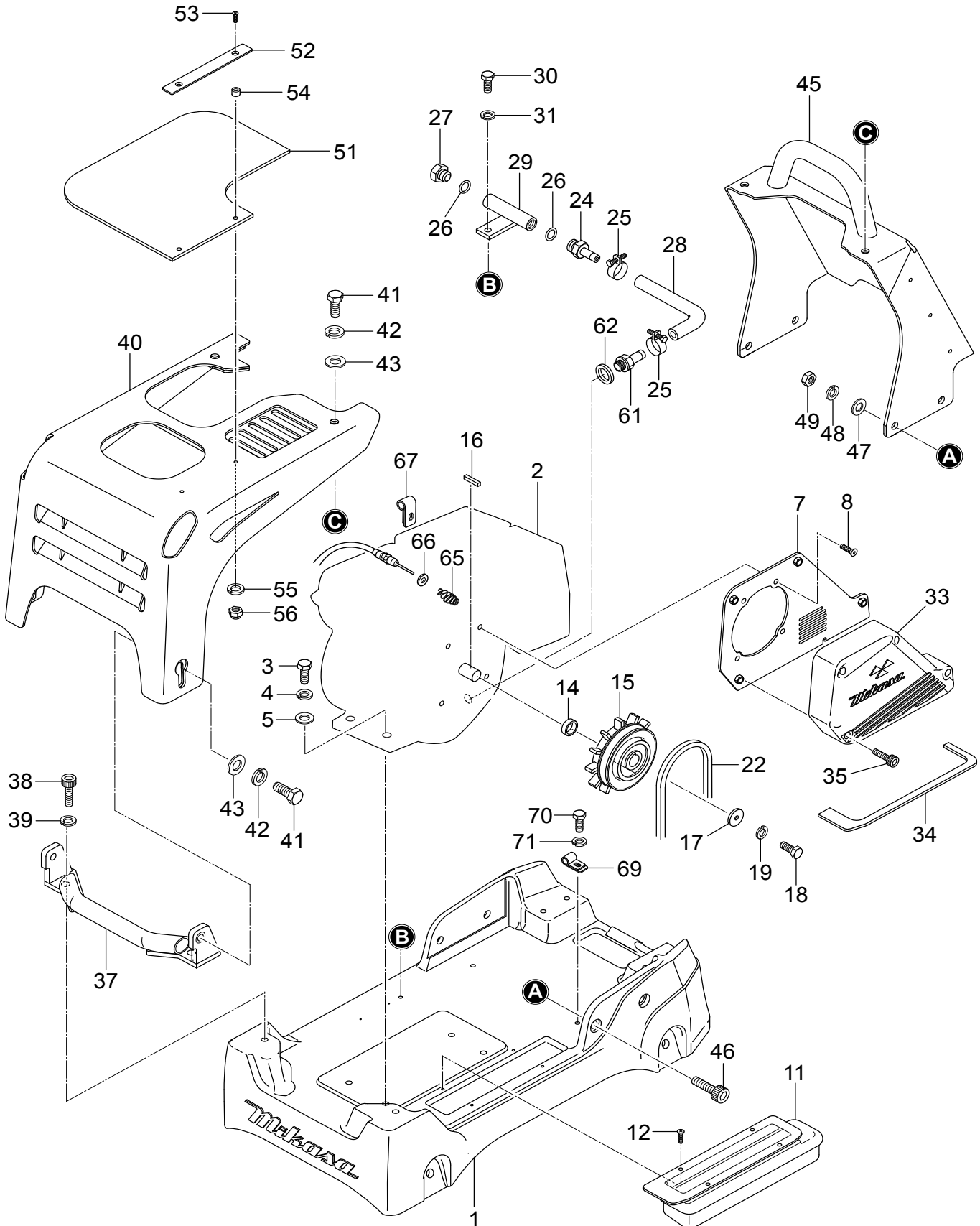

BASE AND ENGINE ASSY.

<u>NO.</u>	<u>PART NO.</u>	<u>PART NAME</u>	<u>QTY.</u>	<u>REMARKS</u>
1	467121160	BASE	1	
2	912227007	ENGINE ASSY., GX270UT2SMXC.....	1.....	S/N C1146 ~ BELOW
2	912227009	ENGINE ASSY., GX270UT2SCM.....	1.....	S/N C1147 ~ ABOVE
3	0105051045	BOLT 10X45	4.....	REPLACES P/N 001221045
4	030210250	WASHER, LOCK M10	4	
5	031110160	WASHER, FLAT M10	4	
7	467351850	BELT COVER, IN	1	
8	009110071	SOCKET HEAD BOLT 10X25	4	
11	467218860	DUST COVER	1	
12	092006010	FLAT HEAD SCREW 6X10	4	
14	952408810	SPACER	1	
15	456343340	CLUTCH ASSY.	1	
16	951400110	KEY 7X7X35	1	
17	952400690	WASHER	1	
18	011208030	BOLT 8X30	1.....	REPLACES P/N 001220830
19	030208200	WASHER, LOCK M8	1	
22	070200453	V-BELT B-45	1	
24	954407310	UNION, DRAIN	1	
25	0091720000	HOSE CLAMP	2	
26	0211140020	GASKET	2	
27	0401140030	PLUG	1	
28	465459390	DRAIN HOSE	1	
29	464457380	DRAIN JOINT	1	
30	014208020	BOLT 8X20.....	1.....	REPLACES P/N 001220820
31	030208200	WASHER, LOCK M8	1	
33	467121100	BELT COVER (OUT)	1	
34	467351800	DUST SPONGE (OUT)	1	
35	001521053	SOCKET HEAD BOLT 10X65	4	
37	467351810	FRONT BUMPER	1	
38	001521435	SOCKET HEAD BOLT 14X35	2	
39	030214350	WASHER, LOCK M14	2	
40	467121130	FRONT COVER	1	
41	001221445	BOLT 14X45	4	
42	030214350	WASHER, LOCK M14	4	
43	031114260	WASHER, FLAT M14	4	
45	467121140	CENTER COVER	1	
46	001521435	SOCKET HEAD BOLT 14X35	4	
47	031114260	WASHER, FLAT M14	4	
48	030214350	WASHER, LOCK M14	4	
49	020314110	NUT M14	4	
51	467466800	RUBBER COVER, UPPER	1	

BASE AND ENGINE ASSY. (CONT'D.)

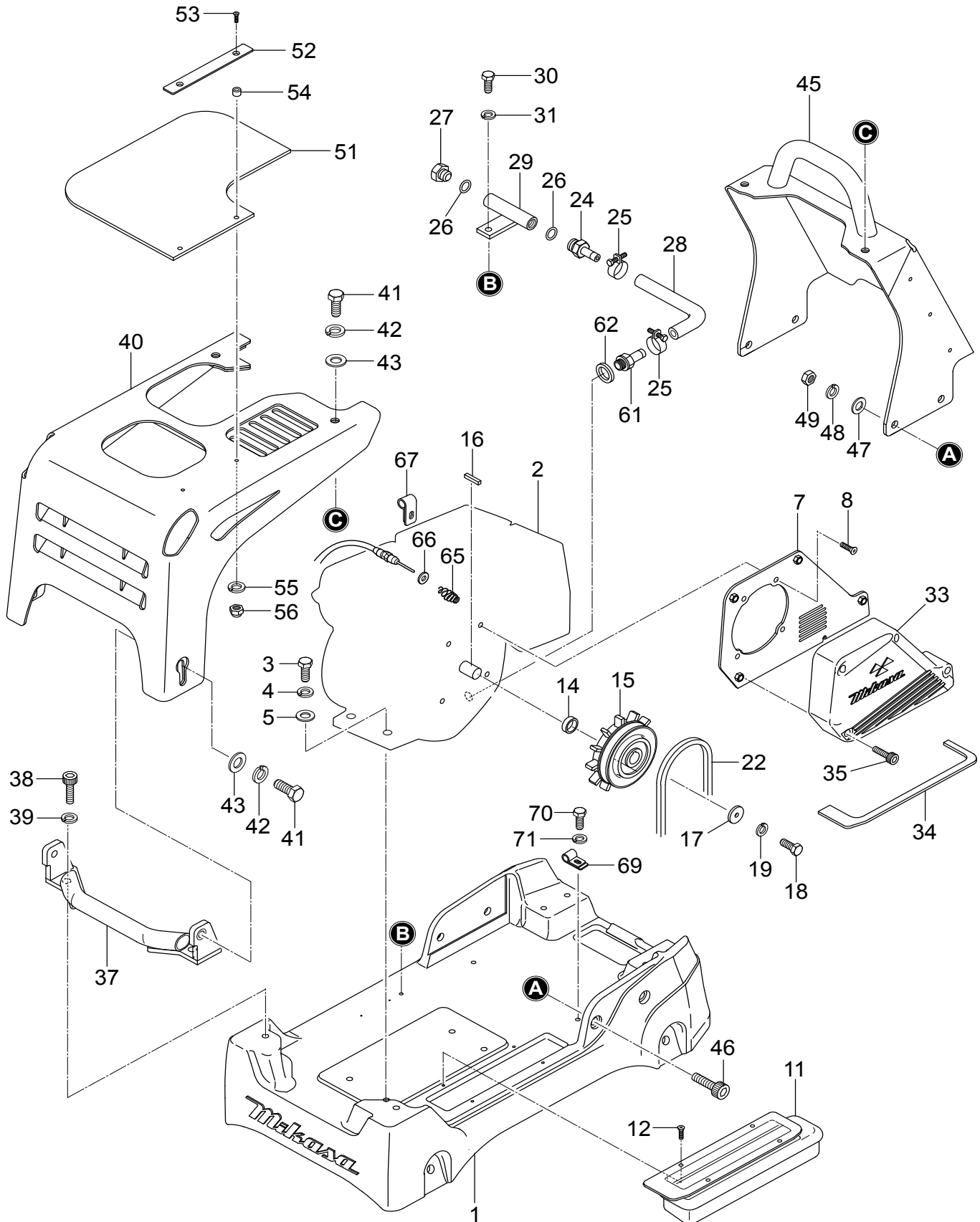

BASE AND ENGINE ASSY. (CONT'D.)

<u>NO.</u>	<u>PART NO.</u>	<u>PART NAME</u>	<u>QTY.</u>	<u>REMARKS</u>
52	467466810	STOPPER, COVER	1	
53	009120424	SOCKET HEAD BOLT 6X25	2	
54	617465130	COLLAR	2	
55	030206150	WASHER, LOCK M6	2	
56	022710607	NYLON NUT M6	2	
61	90131ZE3790	DRAIN JOINT	1	
62	031112230	WASHER, DRAIN PLUG M12	1	REPLACES P/N 9410912000
65	402010110	COIL SPRING	1	REPLACES P/N 0830000010
66	58151	WASHER, FLAT M5	1	REPLACES P/N 031105080
67	2067550101	CLAMP COMPLETE	1	
69	959407260	CLIP	1	
70	012210015	BOLT 10X15.....	1	REPLACES P/N 001221015
71	030210250	WASHER, LOCK M10	1	

ELECTRICAL DEVICE ASSY.

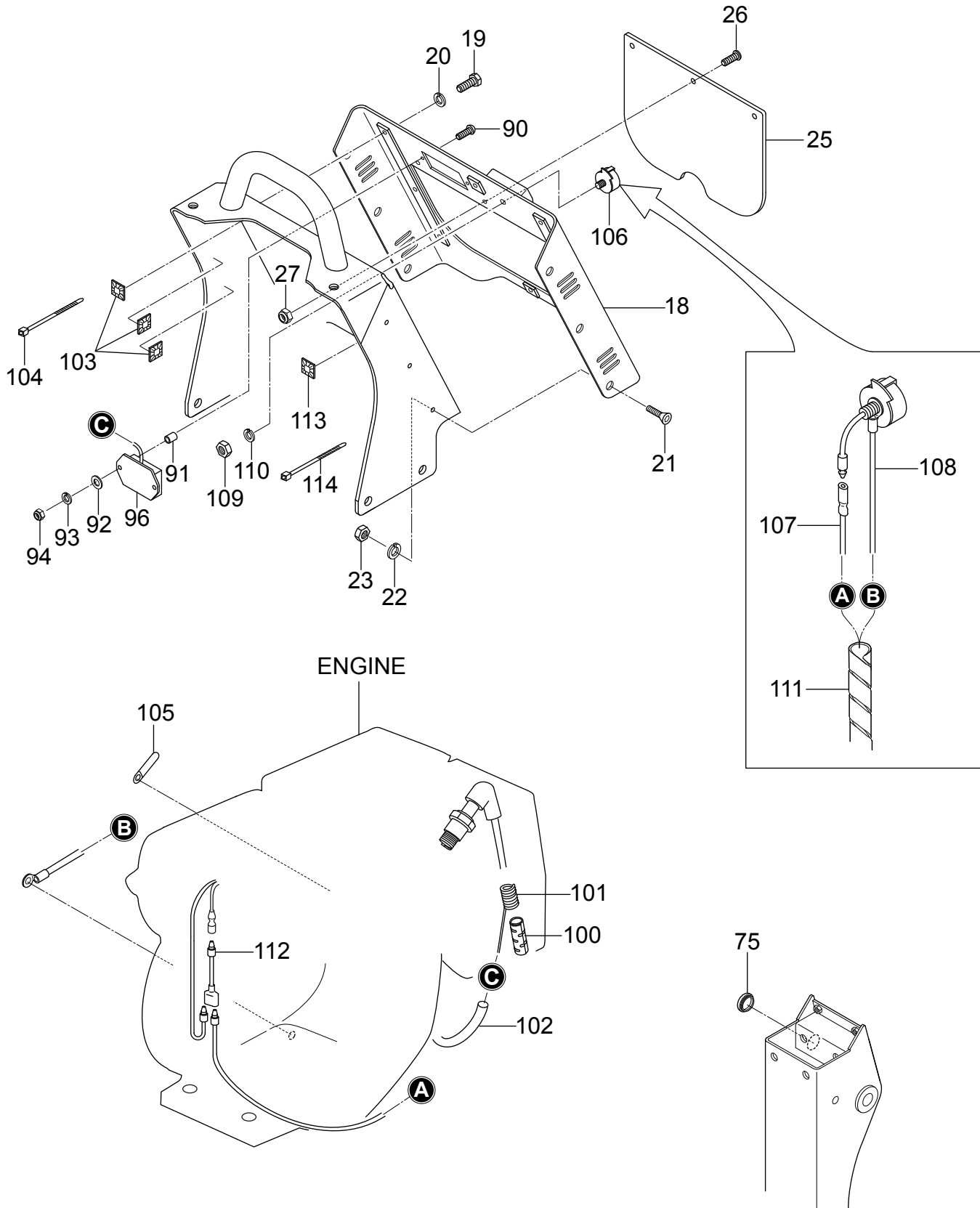

ELECTRICAL DEVICE ASSY.

<u>NO.</u>	<u>PART NO.</u>	<u>PART NAME</u>	<u>QTY.</u>	<u>REMARKS</u>
18	467218910	REAR COVER	1	
19	001220610	BOLT 6X10.....	8.....	REPLACES P/N 001220610
20	030206150	WASHER, LOCK M6	8	
21	009120413	SUNK HEAD BOLT 6X15	6	
22	030206150	WASHER, LOCK M6	6	
23	020306050	NUT M6	6.....	REPLACES P/N 020306050
25	467466950	RUBBER COVER, REAR	1	
26	009110062	SOCKET HEAD SCREW 6X20	3	
27	022710607	NYLON NUT M6	3	
75	515010070	GROMMET	1	
90	009110072	PAN HEAD SCREW 5X35	2	
91	952407930	COLLAR 6X10X13.5	2	
92	031105080	WASHER, FLAT M5	2.....	REPLACES P/N 031105080
93	030205130	WASHER, LOCK M5	2	
94	022710506	NYLON NUT M5	2	
96	955010311	TACH./HOUR METER	1	
100	955010307	CLIP BELT	1	
101	955010308	CURL CORD	1	
102	959026828	RUBBER TUBE	1	
103	955407970	WIRING FIXED BASE	3	
104	454010020	CLAMP	3	
105	2067550101	CLAMP COMPLETE	1	
106	955301010	STOP, SWITCH, ENGINE	1.....	INCLUDES ITEMS W/\$
107\$	617465210	LEAD WIRE	1	
108\$	467466980	LEVER, THROTTLE	1	
109	030208200	WASHER, LOCK M8	1	
110	020308060	NUT M8	1.....	REPLACES P/N 020308060
111\$	959021812	SPIRAL TUBE	1	
112	515450380	WIRE HARNESS	1	
113	955407970	WIRING FIXED BASE	3	
114	454010020	CLAMP	3	

CONTROL ASSY.

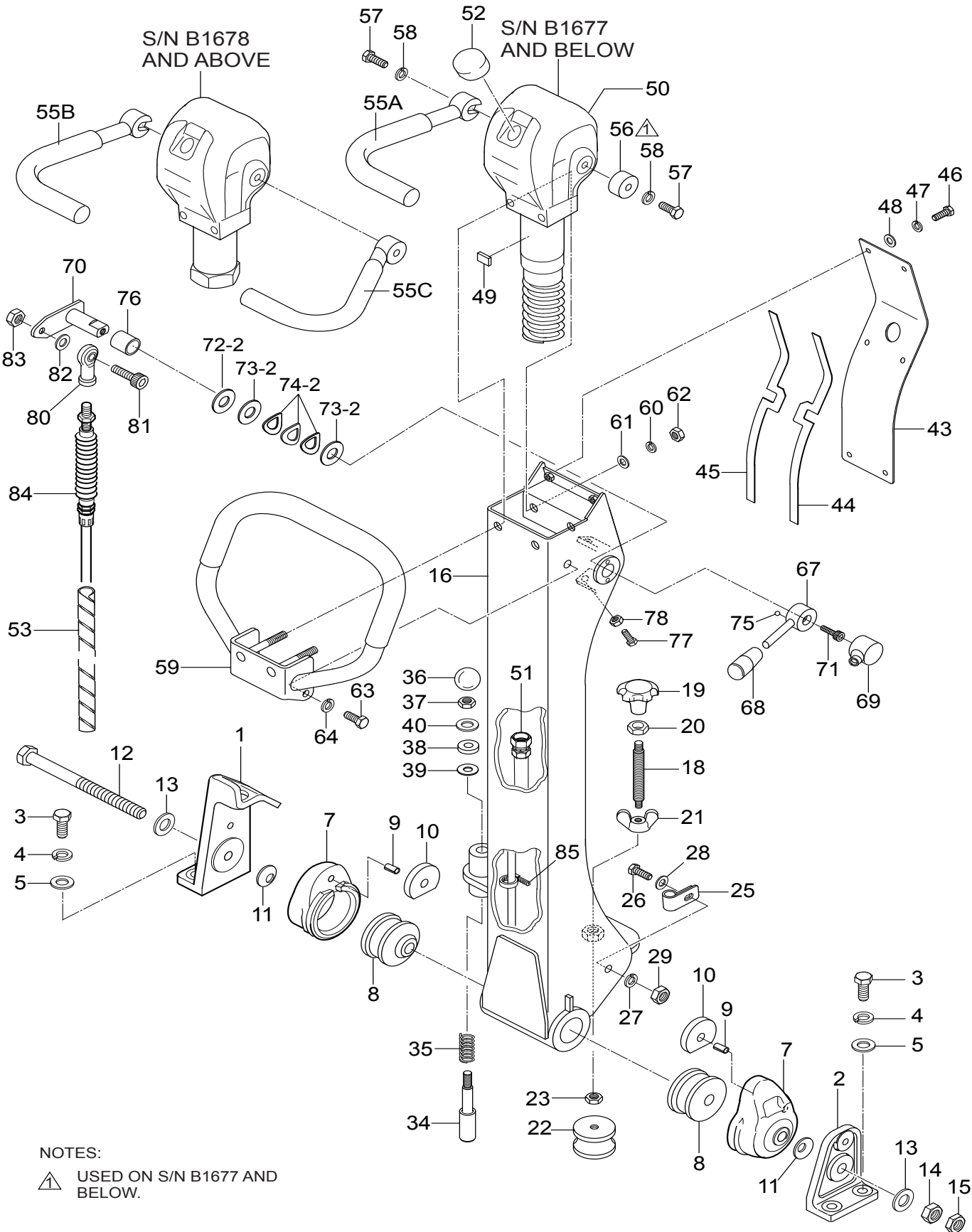

NOTES:

▲ USED ON S/N B1677 AND BELOW.

CONTROL ASSY.

<u>NO.</u>	<u>PART NO.</u>	<u>PART NAME</u>	<u>QTY.</u>	<u>REMARKS</u>
1	467351950	HANDLE BRACKET (R)	1	
2	467351960	HANDLE BRACKET (L)	1	
3	012212035	BOLT 12X35.....	4	REPLACES P/N 001221235
4	030212300	WASHER, LOCK M12	4	
5	031112230	WASHER, FLAT M12	4	
7	456336400	RUBBER COUPLING	2	
8	456449940	SHOCK ABSORBER	2	
9	025306016	SPRING PIN 6X16	2	REPLACES P/N 025406016
10	456449930	RUBBER PLATE	2	
11	032124400	CONICAL WASHER, LOCK M24	2	
12	001221681	BOLT 16X250	1	
13	0401450160	WASHER, FLAT M16	2	REPLACES P/N 031116260
14	020316130	NUT M16	1	
15	020416100	NUT M16	1	
16	467121180	COLUMN, HANDLE BAR	1	
18	455434950	SPINDLE	1	
19	455010030	KNOB	1	
20	020412070	NUT M12	1	
21	022411635	WING NUT M16	1	
22	939010060	SHOCK ABSORBER	1	
23	020310080	NUT M10.....	1	REPLACES P/N 020410060
25	959408930	CLIP 15(M6)	1	
26	011206020	BOLT 6X20.....	1	REPLACES P/N 001220620
27	030206150	WASHER, LOCK M6	1	
28	952404470	WASHER, FLAT M6	1	REPLACES P/N 031106100
29	020106050	NUT M6	1	REPLACES P/N 020306050
34	501402870	HANDLE STOPPER	1	
35	501402880	SPRING, HANDLE	1	
36	959403460	BALL GRIP	1	
37	020310080	NUT M10.....	1	REPLACES P/N 020410060
38	456449980	RUBBER PACKING	1	
39	953405260	PACKING 1/4, COPPER	1	
40	031110160	WASHER, FLAT M10	1	
43	467351980	HANDLE COVER	1	
44	467467340	PACKING (L), HANDLE	1	
45	467467350	PACKING (R), HANDLE	1	
46	0105050616	BOLT 6X15.....	6	REPLACES P/N 001220615
47	030206150	WASHER, LOCK M6	6	
48	952404470	WASHER, FLAT M6	6	REPLACES P/N 031106100
49	464457930	RUBBER PIECE	1	
50	467219140	HYDRAULIC PUMP	1	

CONTROL ASSY. (CONT'D.)

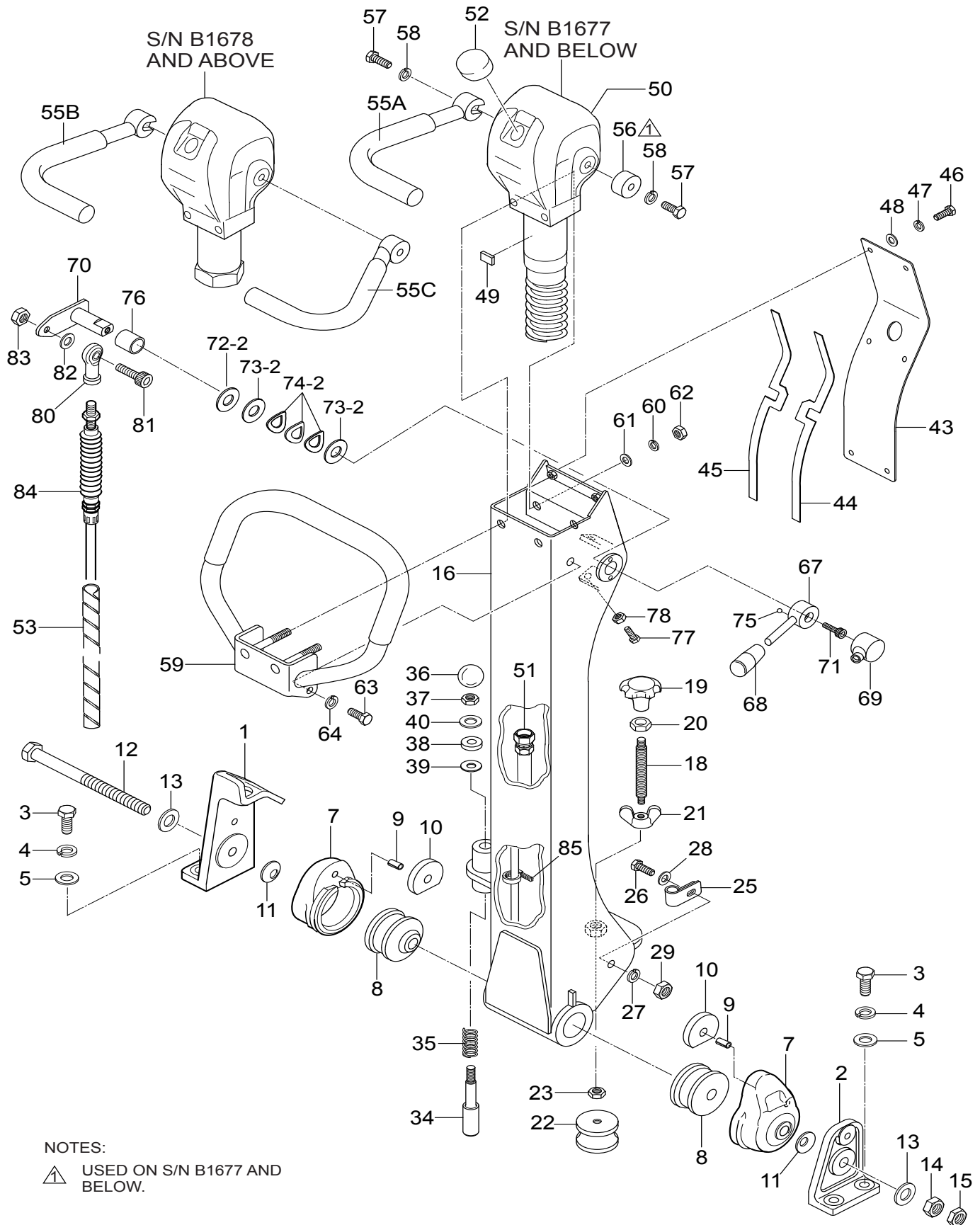

CONTROL ASSY. (CONT'D.)

<u>NO.</u>	<u>PART NO.</u>	<u>PART NAME</u>	<u>QTY.</u>	<u>REMARKS</u>
51	954003110	OIL HOSE	1	
52	458451630	BREATHER CAP	1	
53	959021813	SPIRAL TUBE	1	
55A	464216630	TRAVEL LEVER, RIGHT	1.....	S/N B1677 AND BELOW
55B	464216820	TRAVEL LEVER, RIGHT	1.....	S/N B1678 AND ABOVE
55C	464216830	TRAVEL LEVER, LEFT	1.....	S/N B1678 AND ABOVE
56	464457400	HANDLE BOSS	1.....	S/N B1677 AND BELOW
57	012010030	BOLT 10X30	2.....	REPLACES P/N 001221030
58	030210250	WASHER, LOCK M10	2	
59	467218900	HANDLE W/ RUBBER COVER GRIP	1	
60	030210250	WASHER, LOCK M10	2	
61	031110160	WASHER, FLAT M10	2	
62	020310080	NUT M10	2	
63	0105091025	BOLT 10X25	2.....	REPLACES P/N 001221025
64	030210250	WASHER, LOCK M10	2	
67	467466960	LEVER, THROTTLE	1	
68	959403840	BAR GRIP, I.D. 12MM	1	
69	464457420	COVER, THROTTLE LEVER	1	
70	464457350	ARM, THROTTLE	1.....	INCLUDES ITEMS W/*
71	014208020	SOCKET HEAD BOLT 8X20.....	1.....	REPLACES P/N 001520820
72-2*	0401450160	WASHER, FLAT M16	1.....	REPLACES P/N 031116260
73-2*	458450660	WASHER	2	
74-2*	033910080	CONICAL WASHER, LOCK	3	
75	464457440	STEEL BALL	1	
76	464010010	DRY BUSHING	1	
77	011606025	BOLT 6X25.....	2.....	REPLACES P/N 001220625
78	020106050	NUT M6.....	2.....	REPLACES P/N 020306050
80	464010020	ROD END M5	1	
81	001520520	SOCKET HEAD BOLT 5X20	1	
82	58151	WASHER, FLAT M5.....	1.....	REPLACES P/N 031105080
83	020305040	NUT M5	1	
84	956100070	THROTTLE WIRE	1	
85	454010020	CLAMP	1	

HYDRAULIC HAND PUMP ASSY.

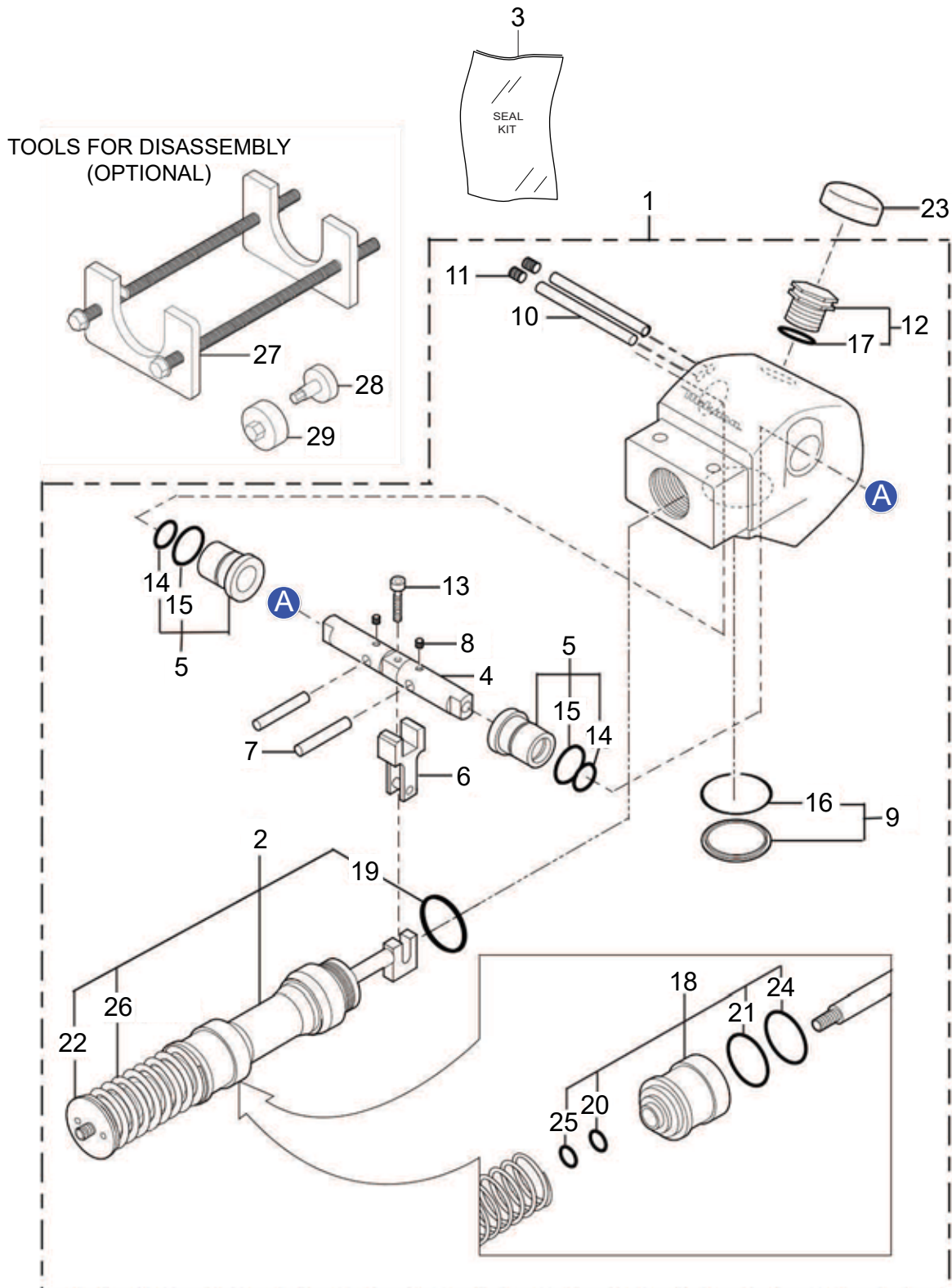

HYDRAULIC HAND PUMP ASSY.

<u>NO.</u>	<u>PART NO.</u>	<u>PART NAME</u>	<u>QTY.</u>	<u>REMARKS</u>
1	467219140	HAND PUMP	1.....	INCLUDES ITEMS W/#
2#	467910020	ACCUMULATOR.....	1.....	INCLUDES ITEMS W/\$ NOT SOLD SEPARATELY
3	464910080	SEAL KIT	1.....	INCLUDES ITEMS W/%
4#	464010040	CONTROL SHAFT	1	
5#	467010020	BUSH.....	2.....	INCLUDES ITEMS W/@
6#	464010060	CAM	1	
7#	464010070	STOPPER	2	
8#	099205005	SCREW, SOCKET HEAD	2	
9#	464010080	PLUG	1.....	INCLUDES ITEMS W/*
10#	464010090	PIN, STOPPER	2	
11#	464010100	PLUG	2	
12#	458010080	BREATHER.....	1.....	INCLUDES ITEMS W/^
13#	001520620	BOLT, SOCKET HEAD.....	1.....	REPLACES P/N 001520620
14@%#	050200200	O-RING, P-20	2	
15@%#	050210220	O-RING, P-22	2.....	REPLACES P/N 050200220
16*%#	050300380	O-RING, S-38	1	
17^%#	050200180	O-RING, P-18	1	
18\$#	464010111	CASE, ACCUMULATOR	1.....	INCLUDES ITEMS W/&
19\$%#	050300400	O-RING, S-40	1	
20\$&%#	050200150	O-RING, P-15	1	
21\$&%#	050100400	O-RING, G-40	1	
22\$#	464010120	PLUG, SPRING	1	
23#	458451630	CAP, BREATHER	1	
24\$&%#	069904010	SEAL, SER-40	1	
25\$&%#	069901010	SEAL, SER-15	1	
26\$#	465910080	SPRING, ACCUMULATOR	1	
27	984010060	SPRING COMPRESSION, TOOL	1	
28	984010040	TOOL A, DISASSEMBLING	1	
29	984010050	TOOL B, DISASSEMBLING	1	

HONDA GX270UT2SMXC/SCM ENG. — CYLINDER HEAD ASSY.

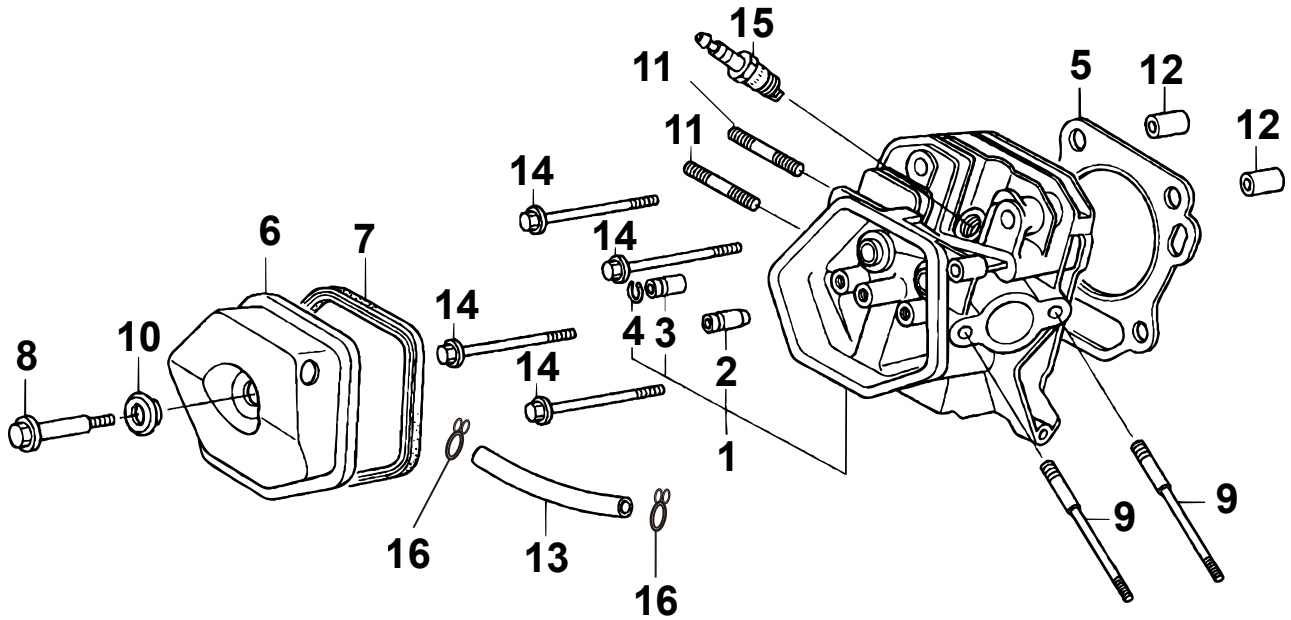

HONDA GX270UT2SMXC/SCM ENG. — CYLINDER HEAD ASSY.

NO.	PART NO.	PART NAME	QTY.	REMARKS
1	12200Z5K405	HEAD COMP., CYLINDER	1.....	INCLUDES ITEMS W/#
2#	12204ZE2306	GUIDE, IN. VALVE (OVERSIZE)	1	
3#	12205ZE2305	GUIDE, EX. VALVE (OVERSIZE)	1	
4#	12216ZE2300	CLIP, VALVE GUIDE	1	
5	12251Z5K003	GASKET, CYLINDER HEAD	1	
6	12310ZE3791	COVER COMP., HEAD	1	
7	12391ZE2020	PACKING, HEAD COVER	1	
8	90014Z5T000	BOLT, HEAD COVER	1	
9	90042ZE2000	BOLT, STUD 8X123	2	
10	90441ZE2010	WASHER COMP., HEAD COVER	1	
11	92900080320E	BOLT, STUD 8X32	2	
12	9430112200	PIN, DOWEL 12X20	2	
13	12315ZE3840	TUBE, BREATHER	1	
14	957011008000	BOLT, FLANGE 10X80	4	
15◆	0650140480	SPARK PLUG (BPR6ES)	1	
15◇	9807956846	SPARK PLUG (BPR6ES).....	1.....	REPLACES P/N 9807956876
16	17316611000	CLIP, BREATHER TUBE	1	

NOTICE

- ◆ GX270UT2SMXC
- ◇ GX270UT2SCM

HONDA GX270UT2SMXC/SCM ENG. — CYL. BARREL ASSY.

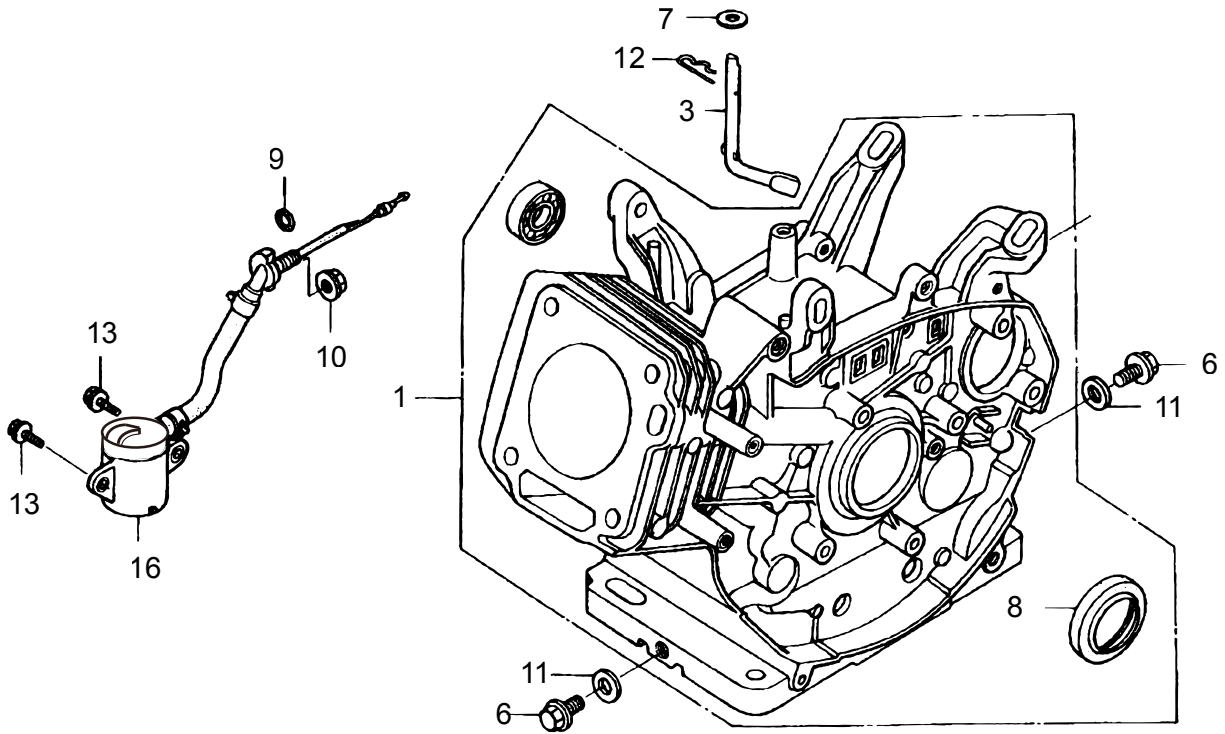

HONDA GX270UT2SMXC/SCM ENG. — CYL. BARREL ASSY.

<u>NO.</u>	<u>PART NO.</u>	<u>PART NAME</u>	<u>QTY.</u>	<u>REMARKS</u>
1	12000Z5K406	BARREL ASSY., CYLINDER	1.....	INCLUDES ITEMS W/#
3	16541ZE2010	SHAFT, GOVERNOR ARM	1	
6	90131896650	BOLT, DRAIN PLUG	2	
7	90446KE1000	WASHER, 8.2X17X0.8	1	
8#	91201Z1D003	OIL SEAL, 30X46X8	1	
9	91353671003	O-RING, 14MM	1.....	REPLACES P/N 91353671004
10	9405010000	FLANGE NUT, M10	1	
11	031112230	WASHER, DRAIN PLUG M12	2.....	REPLACES P/N 9410912000
12	9425110000	PIN, LOCK 10MM	1	
13	957010601200	FLANGE BOLT, 6X12	2	
16	354800ZF6003	SWITCH ASSY., OIL LEVEL	1	

HONDA GX270UT2SMXC/SCM ENG. — CRANKCASE CVR. ASSY.

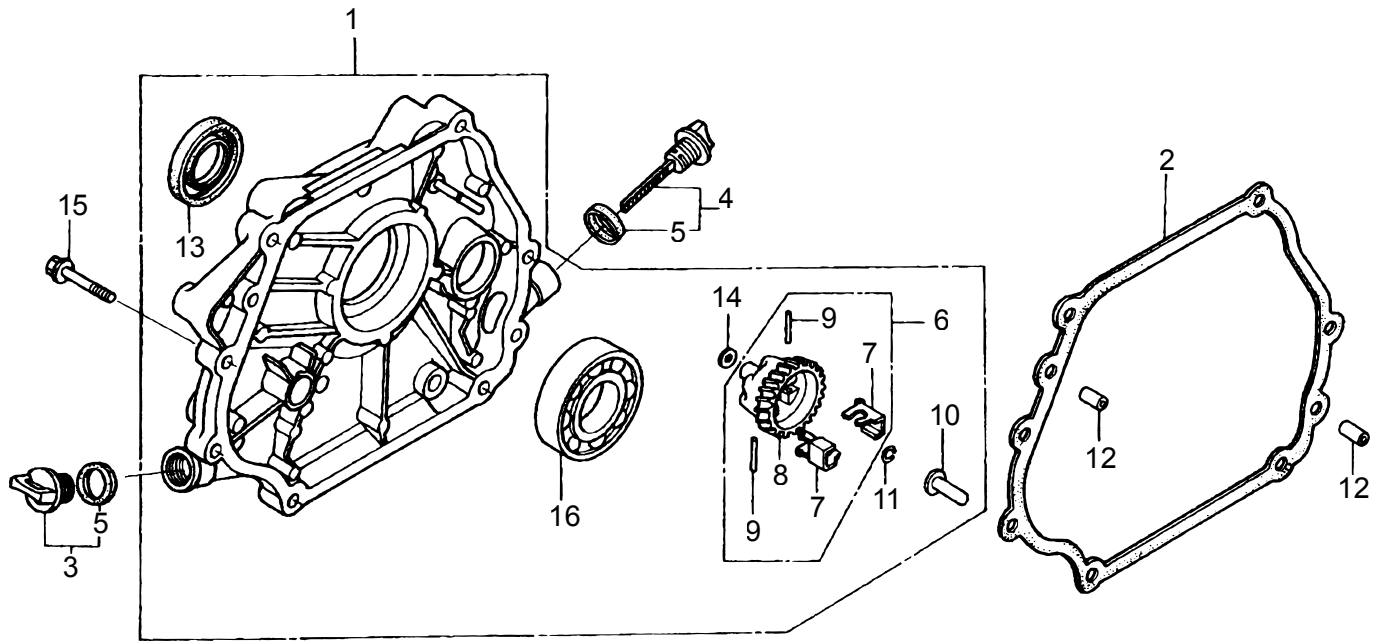

HONDA GX270UT2SMXC/SCM ENG. — CRANKCASE CVR. ASSY.

<u>NO.</u>	<u>PART NO.</u>	<u>PART NAME</u>	<u>QTY.</u>	<u>REMARKS</u>
1	11300Z1D810	COVER ASSY., CRANKCASE.....	1.....	INCLUDES ITEMS W/\$
2	11381Z5K000	PACKING, CASE COVER	1	
3	15600Z0T820	CAP ASSY., OIL FILLER	1.....	INCLUDES ITEMS W/#
4	15600Z1C000	CAP ASSY., OIL FILLER	1.....	INCLUDES ITEMS W/@
5#@	15625Z0T800	PACKING, OIL FILLER CAP	2	
6\$	16510ZE2000	GOVERNOR ASSY.....	1.....	INCLUDES ITEMS W/%
7%	16511ZE2000	WEIGHT, GOVERNOR	2	
8%	16512ZE2000	HOLDER, GOVERNOR WEIGHT	1	
9%	16513ZE2000	PIN, GOVERNOR WEIGHT	2	
10\$	16531Z0A000	SLIDER, GOVERNOR	1	
11\$	90602ZE1000	CLIP, GOVERNOR HOLDER	1	
12	90701HC4000	PIN, DOWEL 8X12	2	
13\$	91201Z1D003	OIL SEAL, 30X46X8	1	
14\$	58176	WASHER, FLAT 6MM.....	1.....	REPLACES P/N 9410106800
15	957010803500	FLANGE BOLT, 8X35	7	
16\$	961006206000	BALL BEARING 6206	1	

HONDA GX270UT2SMXC/SCM ENG. — CRANKSHAFT ASSY.

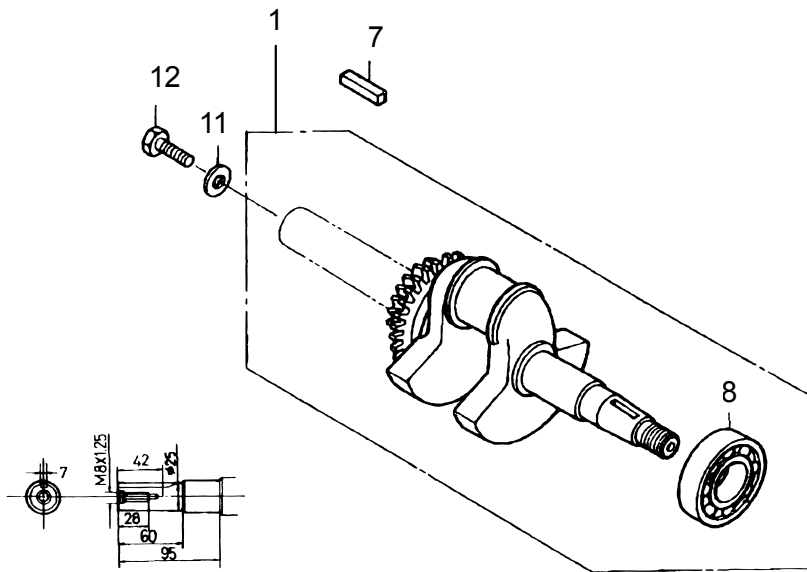

HONDA GX270UT2SMXC/SCM ENG. — CRANKSHAFT ASSY.

<u>NO.</u>	<u>PART NO.</u>	<u>PART NAME</u>	<u>QTY.</u>	<u>REMARKS</u>
1	13310ZH9010	CRANKSHAFT COMP.	1.....	INCLUDES ITEMS W/#
7	90741889810	KEY, 7X7X33	1.....	REPLACES P/N 90741805000
8#	91001ZH9003	BEARING, BALL	1	
11◆	90534706010	WASHER, LOCK 8MM	1	
12◆	92101080250A	BOLT, 8X25	1	

NOTICE

◆ GX270UT2SMXC

◇ GX270UT2SCM

HONDA GX270UT2SMXC/SCM ENG. — PISTON ASSY.

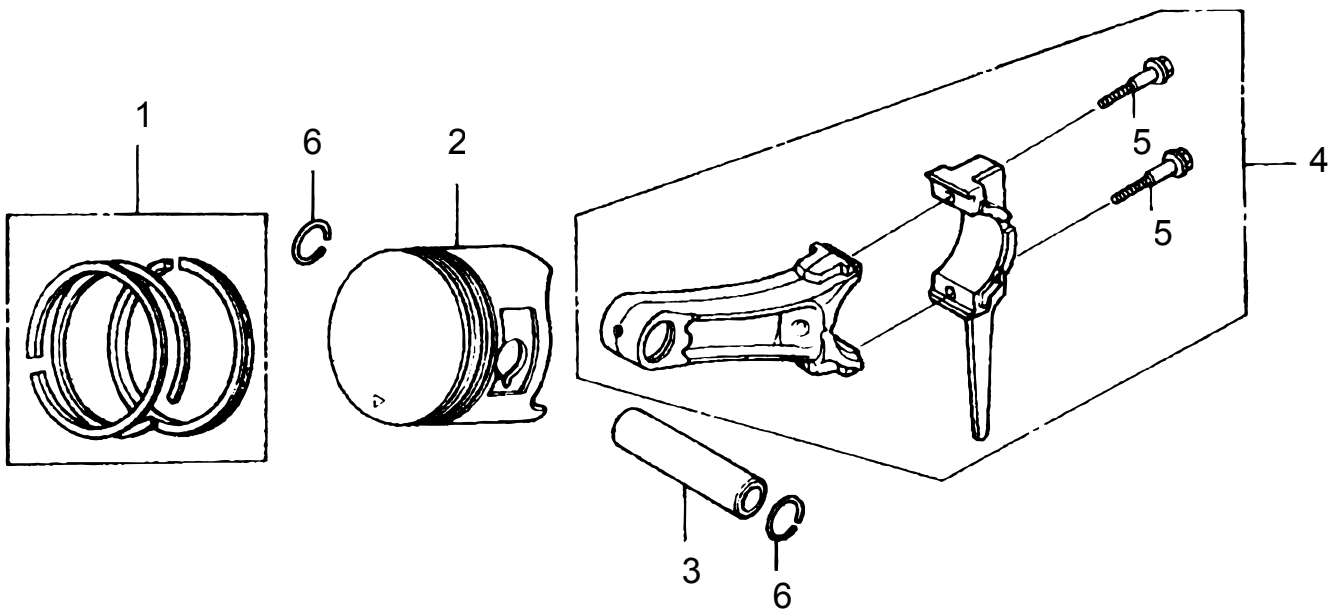

HONDA GX270UT2SMXC/SCM ENG. — PISTON ASSY.

NO.	PART NO.	PART NAME	QTY.	REMARKS
1	13010Z5K004	RING SET, PISTON (STD)	1	
1	13011Z5K004	RING SET, PISTON 0.25 OS	1	
1	13012Z5K004	RING SET, PISTON 0.50 OS	1	
1	13013Z5K004	RING SET, PISTON 0.75 OS	1	
2	13101Z5K000	PISTON (STD)	1	
2◇	13101Z1D900	PISTON (STD)	1	
2	13102Z5K000	PISTON (0.25 OS)	1	
2	13103Z5K000	PISTON (0.50 OS)	1	
2	13104Z5K000	PISTON (0.75 OS)	1	
3	13111Z5K000	PIN, PISTON	1	
4◆	13200Z1D000	ROD ASSY., CONNECTING (STD)	1	INCLUDES ITEMS W/#
4◇	13200Z1D900	ROD ASSY., CONNECTING (STD)	1	INCLUDES ITEMS W/%
4◆	13200Z1D305	ROD ASSY., CONNECTING/0.25UN.....	1	INCLUDES ITEMS W/\$
5#%\$	90001ZE8000	BOLT, CONNECTING ROD	2	
6	90551ZE1000	CLIP, PISTON PIN 18MM	2	

NOTICE

◆ GX270UT2SMXC

◇ GX270UT2SCM

HONDA GX270UT2SMXC/SCM ENG. — CAMSHAFT ASSY.

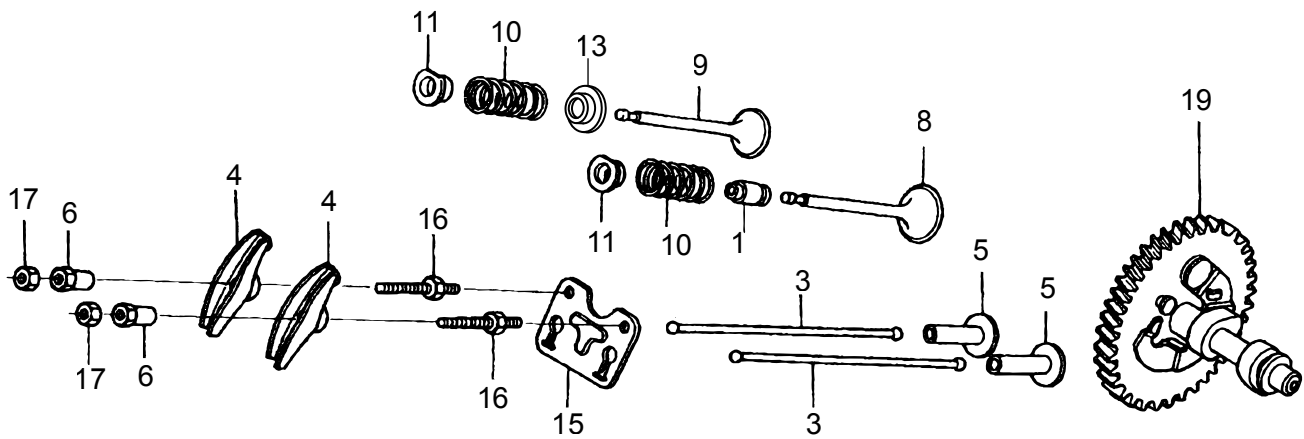

HONDA GX270UT2SMXC/SCM ENG. — CAMSHAFT ASSY.

<u>NO.</u>	<u>PART NO.</u>	<u>PART NAME</u>	<u>QTY.</u>	<u>REMARKS</u>
1	12209ZE8003	SEAL, VALVE STEM	1	
3	14410Z1D000	ROD, PUSH	2	
4	14431ZE2010	ARM, VALVE ROCKER	2	
5	14441ZE2000	LIFTER, VALVE	2	
6◆	14451ZE1013	PIVOT, ROCKER ARM	2	
6◇	14451Z4M000	PIVOT, ROCKER ARM	2	
8	14711Z5K900	VALVE, IN.	1	
9	14721Z5K900	VALVE, EX.	1	
10	14751Z1C000	SPRING, VALVE	2	
11	14771Z8S000	RETAINER, VALVE SPRING	2	
13	14775ZE2010	SEAT, VALVE SPRING	1	
15	14791Z1D000	PLATE, PUSH ROD GUIDE	1	
16	90012ZE0010	BOLT, PIVOT, 8MM	2	
17	90206ZE1000	NUT, PIVOT ADJUSTING	2	
19	14100Z5K910	CAMSHAFT COMP./STD/PRESS FIT	1	

NOTICE

◆ GX270UT2SMXC

◇ GX270UT2SCM

HONDA GX270UT2SMXC/SCM ENG. — RECOIL STARTER ASSY.

<u>NO.</u>	<u>PART NO.</u>	<u>PART NAME</u>	<u>QTY.</u>	<u>REMARKS</u>
1	28400Z5K305ZB	RECOIL STARTER ASSY.	1.....	INCLUDES ITEMS W/#
2#	28410ZE2W01ZB	CASE COMP., RECOIL STARTER	1	
3#	28421ZE2W01	PULLEY, RECOIL STARTER	1	
4#	28422ZE2W01	RATCHET, STARTER	2	
5#	28441ZE2W01	SPRING, FRICTION	1	
6#	28442ZE2W01	SPRING, STARTER RETURN	1	
7#	28443ZE2W01	SPRING, RATCHET	2	
8#	28444ZE2W01	RETAINER, SPRING	1	
10#	28462ZE2W11	ROPE, RECOIL STARTER	1	
11#	90004ZE2W01	SCREW, CENTER	1	
12	957010601000	FLANGE BOLT 6X10	3	
13#	28461Z5T305	GRIP, STARTER	1	
14#	28463Z5T013	GRIP, REINFORCEMENT	1	

HONDA GX270UT2SMXC/SCM ENG. — FAN COVER ASSY.

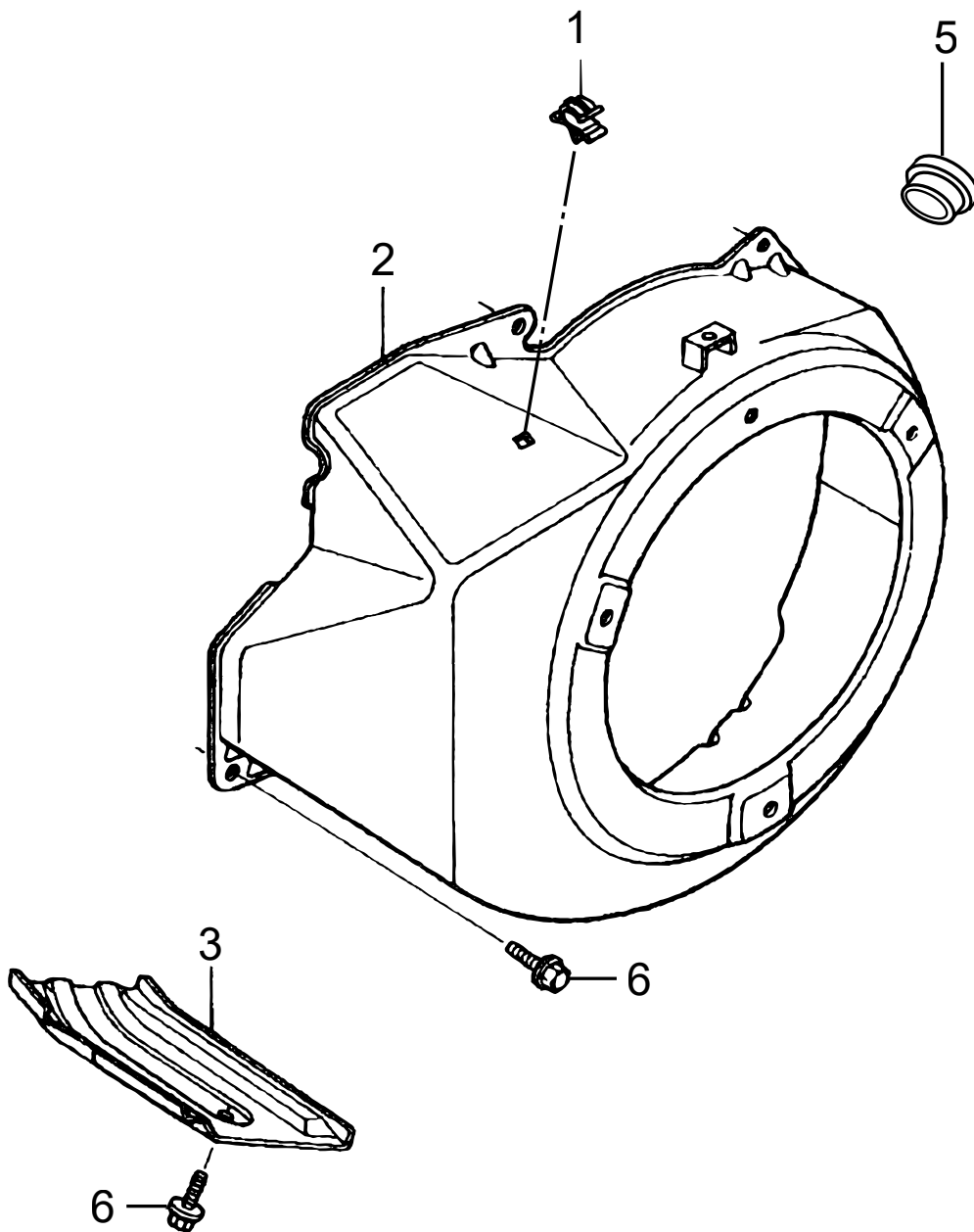

HONDA GX270UT2SMXC/SCM ENG. — FAN COVER ASSY.

<u>NO.</u>	<u>PART NO.</u>	<u>PART NAME</u>	<u>QTY.</u>	<u>REMARKS</u>
1◇	16731ZE2003	CLIP, TUBE	1	
2	19610Z5K000ZA	COVER, COMP. FAN	1	
3	19631Z5K000	SHROUD	1	
5	81329567020	GROMMET, DRAIN HOLE	1	
6	90013883000	FLANGE BOLT 6X12	6	

NOTICE

◆ GX270UT2SMXC

◇ GX270UT2SCM

HONDA GX270UT2SMXC/SCM ENG. — CARBURETOR ASSY.

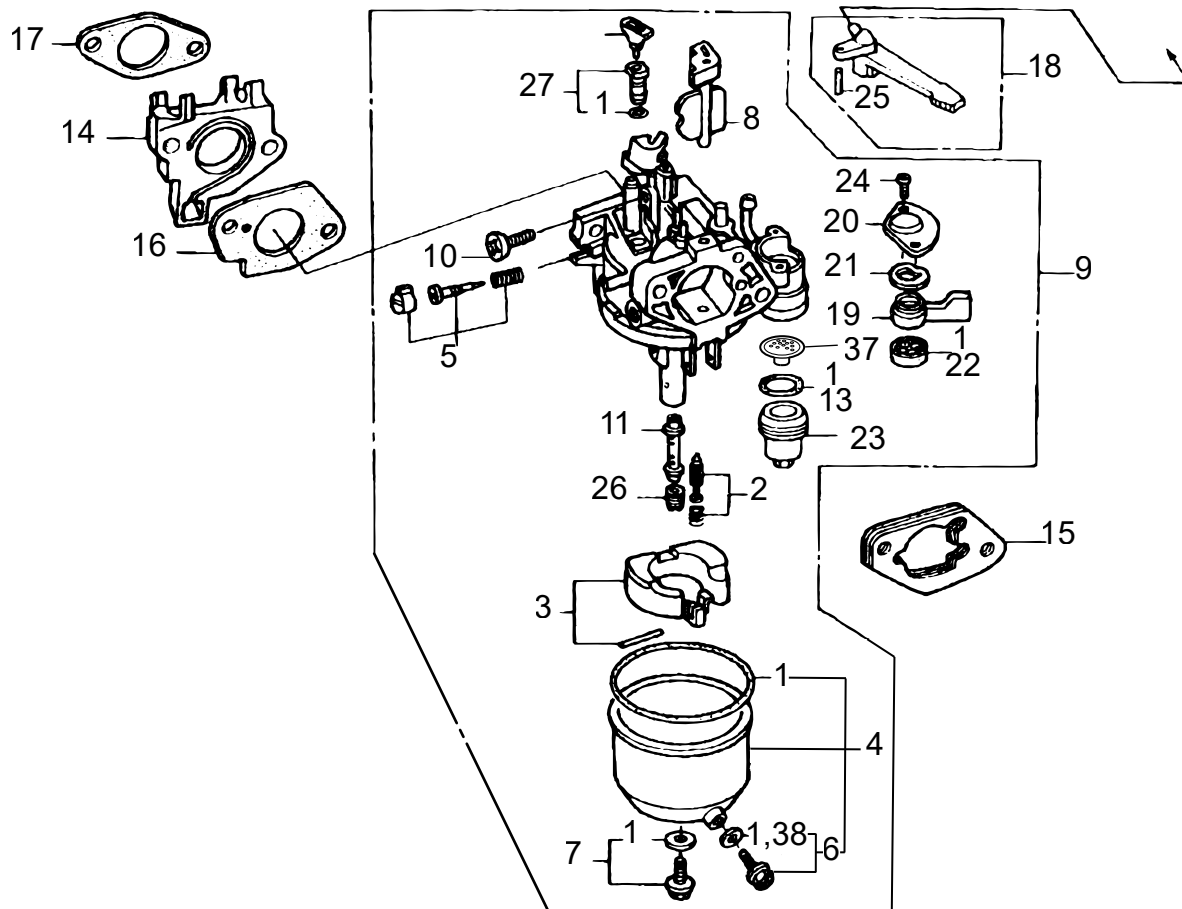

NOTICE

Gasket set, item 1 included with items 4, 7, 13, 22, 27 and 38.

HONDA GX270UT2SMXC/SCM ENG. — CARBURETOR ASSY.

NO.	PART NO.	PART NAME	QTY.	REMARKS
1\$%●	16010ZE2812	GASKET SET	1	
2\$%	16011ZA0931	VALVE SET, FLOAT	1	
3\$%	16013Z1C003	FLOAT SET	1	
4\$%	16015Z5T901	CHAMBER SET, FLOAT	1	INCLUDES ITEM W/●
5\$%	16016ZH7W01	SCREW SET, PILOT	1	
6\$%	16024Z5T901	SCREW SET, DRAIN	1	
7\$%	16028Z5T901	SCREW SET	1	INCLUDES ITEM W/●
8\$%	16044ZE2005	CHOKE SET	1	
9	16100Z5K702	CABURETOR ASSY. BE75N A (◆ ENGINE)	1	INCLUDES ITEMS W/\$
9	16100Z5K781	CABURETOR ASSY. BE75T A (◇ ENGINE)	1	INCLUDES ITEMS W/%
10\$%	16124ZE0005	SCREW, THROTTLE STOP	1	
11\$%	16166Z5K701	NOZZLE MAIN	1	
13\$%	16955283000	PACKING, CUP	1	REPLACES P/N 16173001004 INCLUDES ITEM W/●
14	16211ZE2010	INSULATOR, CARBURETOR	1	
15	16220ZA0702	SPACER COMP., CARBURETOR	1	
16	16221Z5K000	PACKING, CARBURETOR	1	
17	16212Z5K000	PACKING, INSULATOR	1	
18	16610ZE1000	CHOKE LEVER COMP.	1	INCLUDES ITEMS W/#
19\$%	16953ZE1812	LEVER, COCK	1	
20\$%	16954ZE1812	PLATE, LEVER SETTING	1	
21\$%	16956ZE1811	SPRING, COCK LEVER	1	
22\$%	16957ZE1812	PACKING, FUEL COCK	1	
23\$%	16967ZE0811	CUP, FUEL STRAINER	1	
24\$%	93500030060H	SCREW 3X6	2	
25#	9430520122	SPRING PIN 2X12	1	
26◆\$	99101ZH80920	JET, MAIN #92	1	
26◇%	99101ZH80950	JET, MAIN #95	1	
27\$%	99204ZE20380	JET SET, PILOT, #38	1	INCLUDES ITEM W/●
37\$	16959Z5T901	FILTER, CUP	1	
38◇%	16141Z0S003	WASHER, FLAT	1	INCLUDES ITEM W/●

NOTICE

◆ GX270UT2SMXC

◇ GX270UT2SCM

HONDA GX270UT2SMXC ENG. — AIR CLEANER ASSY.

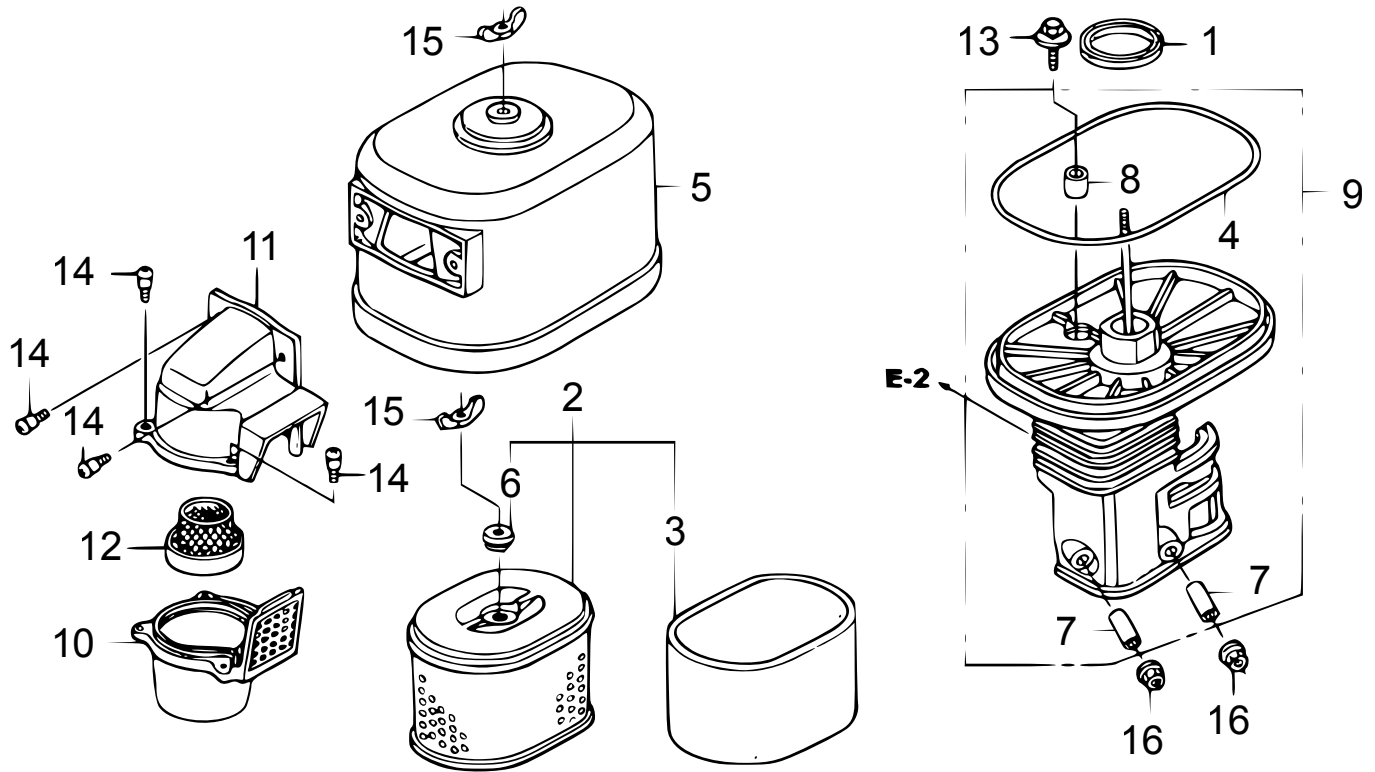

HONDA GX270UT2SMXC ENG. — AIR CLEANER ASSY.

<u>NO.</u>	<u>PART NO.</u>	<u>PART NAME</u>	<u>QTY.</u>	<u>REMARKS</u>
1	16271ZE2010	PACKING, ELBOW	1	
2	17210ZE3505	AIR CLEANER ELEMENT	1.....	INCLUDES ITEMS W/#
3#	17218ZE3505	FILTER, OUTER	1	
4\$	17219ZE3840	PACKING, AIR CLEANER COVER	1	
5	17230ZE3841	COVER COMP., AIR CLEANER (CYCL)	1	
6#	17232891000	GROMMET, AIR CLEANER	1	
7\$	17238ZE2310	COLLAR, AIR CLEANER	2	
8\$	17239ZE3840	COLLAR B, AIR CLEANER	1	
9	17410ZE3841	ELBOW COMP., AIR CLEANER.....	1.....	INCLUDES ITEMS W/\$
10	17470ZE3842	CASE COMP., PRE-AIR CLEANER	1	
11	17475ZE3841	CAP, PRE-AIR CLEANER	1	
12	17476ZE3841	GUIDE, PRE-AIR CLEANER	1	
13	90009Z1C000	BOLT, WASHER 6X22	1	
14	90142MB0000	SCREW, PAN 5X16.5	5	
15	90325044000	NUT, TOOL BOX SETTING	2	
16	9405006000	FLANGE NUT 6MM	2	

HONDA GX270UT2SCM ENG. — AIR CLEANER ASSY.

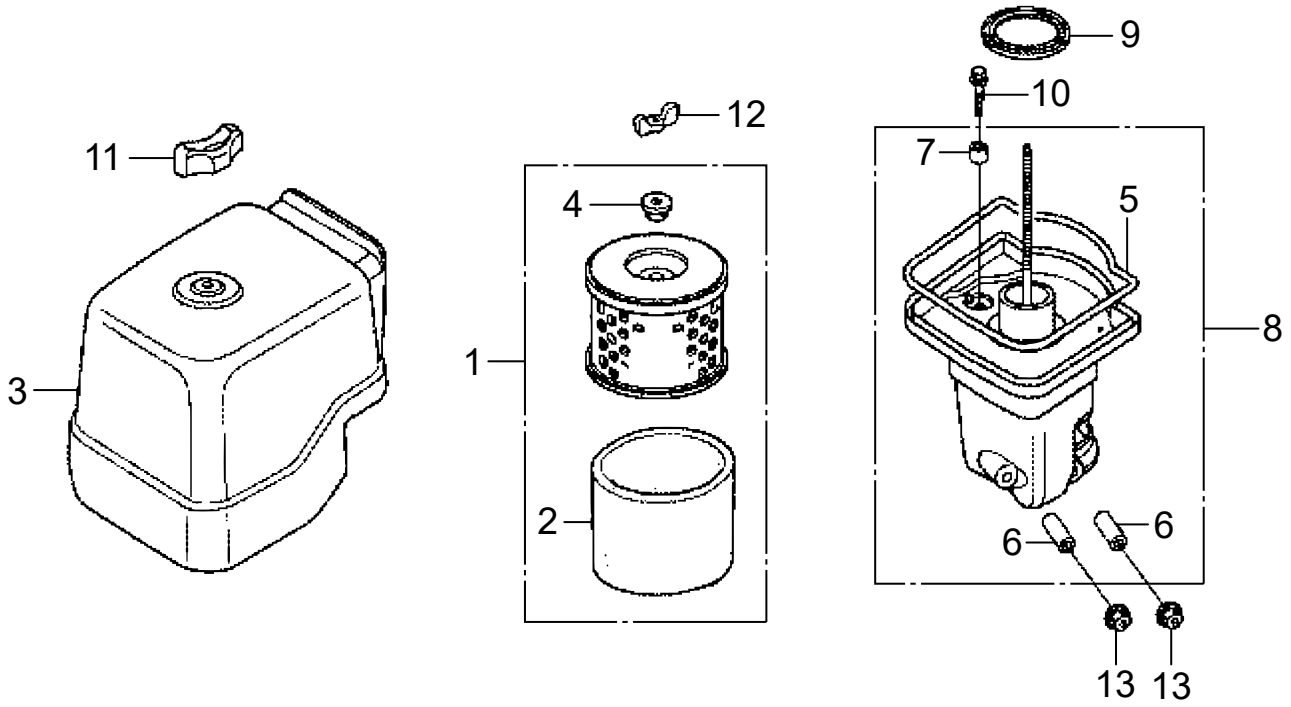

HONDA GX270UT2SCM ENG. — AIR CLEANER ASSY.

<u>NO.</u>	<u>PART NO.</u>	<u>PART NAME</u>	<u>QTY.</u>	<u>REMARKS</u>
1	17210Z1C781	ELEMENT, AIR CLEANER	1.....	INCLUDES ITEMS W/#
2#	17218Z1C780	FILTER, OUTER	1	
3	17230Z1C780	COVER ASSY., AIR CLEANER	1	
4#	17232891000	GROMMET, AIR CLEANER	1	
5%	17233Z1C780	SEAL, AIR CLEANER COVER	1	
6%	17238ZE2310	COLLAR, AIR CLEANER	2	
7%	17239ZE3840	COLLAR B, AIR CLEANER	1	
8	17410Z1C780	ELBOW COMPLETE, AIR CLEANER	1.....	INCLUDES ITEMS W/%
9	17417Z5T000	PACKING, AIR CLEANER CASE	1	
10	90009Z1C000	BOLT WITH WASHER 6X22	1	
11	90300Z4M800	NUT, AIR CLEANER	1	
12	90325044000	NUT, TOOL BOX SETTING	1	
13	9405006000	FLANGE NUT 6MM	2	

HONDA GX270UT2SMXC/SCM ENG. — MUFFLER ASSY.

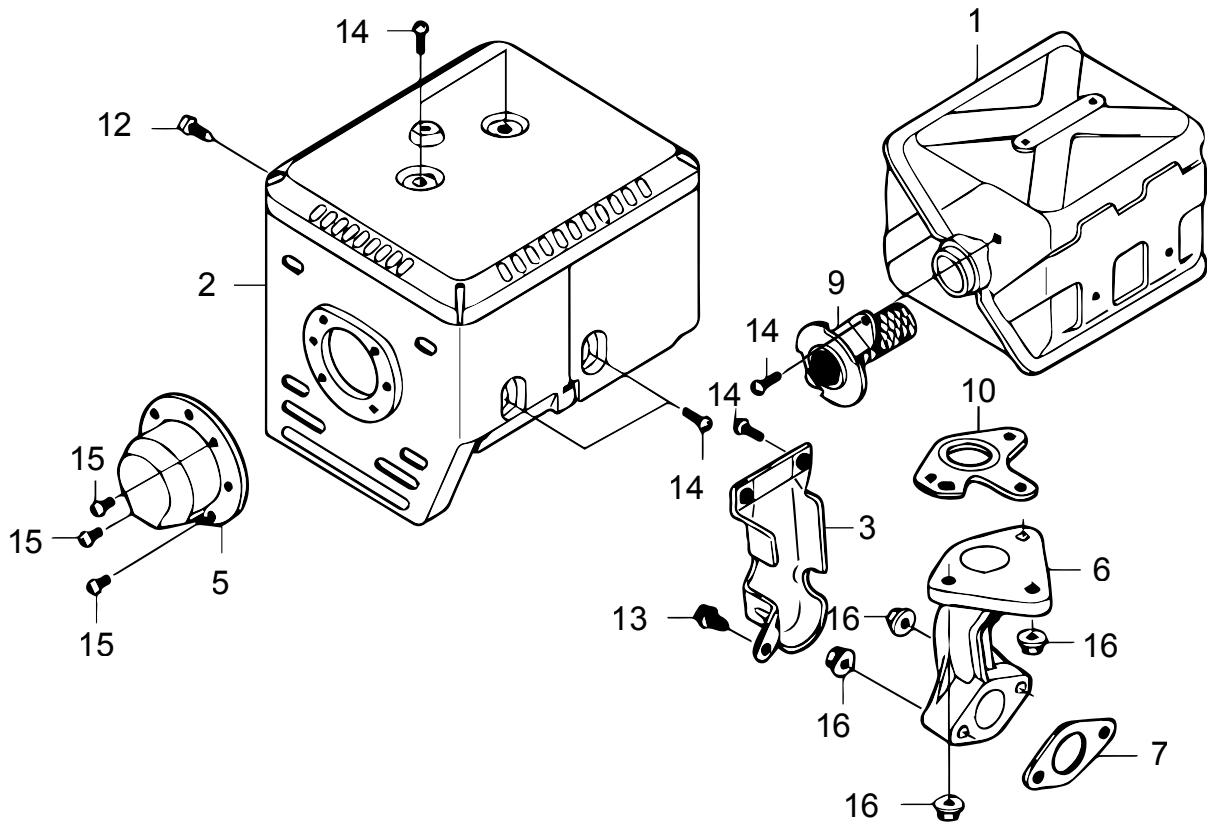

HONDA GX270UT2SMXC/SCM ENG. — MUFFLER ASSY.

<u>NO.</u>	<u>PART NO.</u>	<u>PART NAME</u>	<u>QTY.</u>	<u>REMARKS</u>
1	18310Z5K010	MUFFLER COMPLETE	1	
2	18320Z5K000	PROTECTOR COMPLETE, MUFFLER	1	
3	18323ZE2W00	PROTECTOR, EXHAUST PIPE	1	
5	18331ZE3811	CAP, MUFFLER	1	
6	18331Z5T000	PIPE, EXHAUST	1	
7	18333Z1C801	GASKET, EXHAUSTPIPE	1	
9	18350Z5T800	ARRESTER COMP., SPARK	1	
10	18381ZE2W10	GASKET, MUFFLER (ARRESTER)	1	
12	90006ZE2000	TAPPING SCREW 6X10	1	
13	90013883000	FLANGE BOLT 6X12	1	
14	90050ZE1000	TAPPING SCREW 5X8	8	
15	90055ZE1000	TAPPING SCREW 4X6	3	
16	9405008000	FLANGE NUT M8	5	

HONDA GX270UT2SMXC/SCM ENG. — FUEL TANK ASSY.

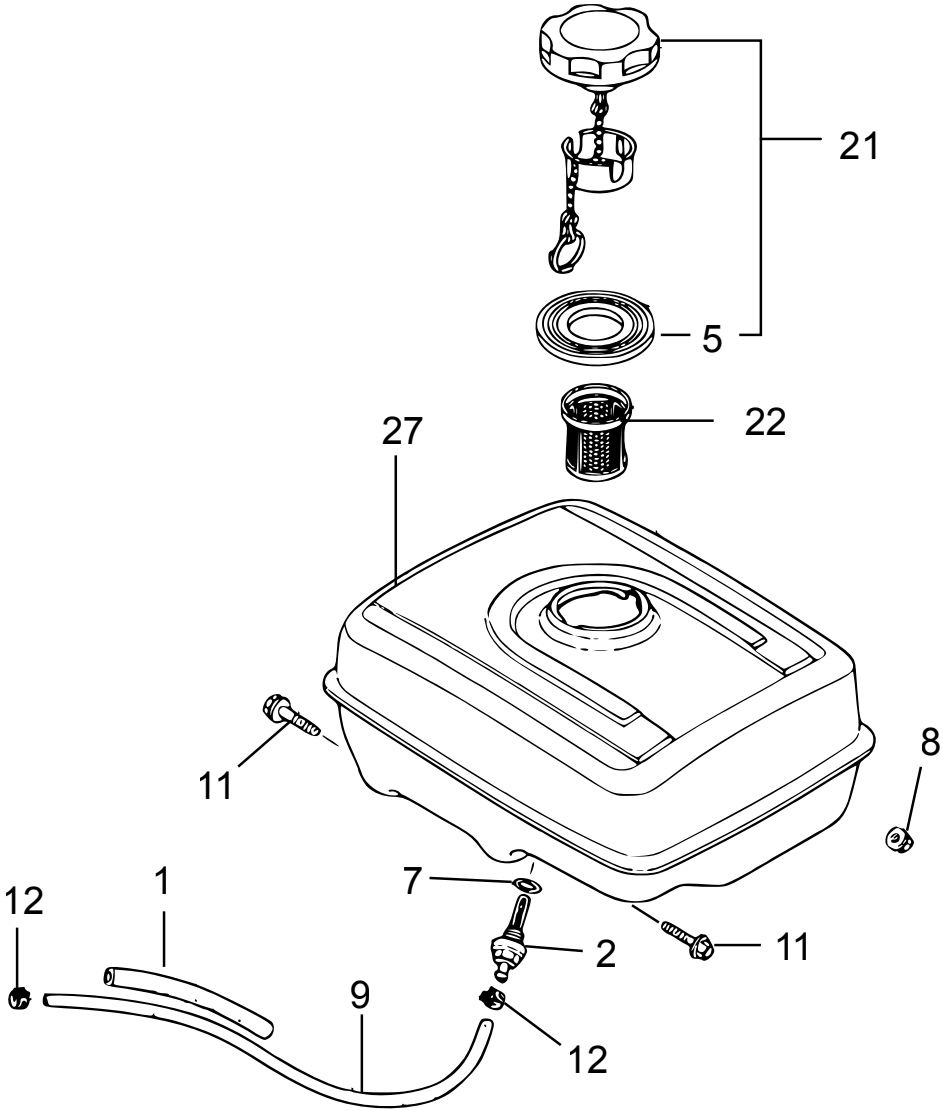

HONDA GX270UT2SMXC/SCM ENG. — FUEL TANK ASSY.

<u>NO.</u>	<u>PART NO.</u>	<u>PART NAME</u>	<u>QTY.</u>	<u>REMARKS</u>
1	16854ZH8000	RUBBER, SUPPORT (107MM)	1	
2	16955ZE1010	JOINT, FUEL TANK	1	
5#	17631Z0T801	PACKING, FUEL FILLER CAP	1	
7	91353671004	O-RING 14MM	1.....	REPLACES P/N 91353671004
8	9405008000	FLANGE NUT M8	2	
9	91424Z5K003	TUBE, FUEL 4.5X210	1	
11	957010802500	FLANGE BOLT 8X25	2	
12	950024080008	CLAMP, TUBE (D8)	2	
21	17620Z4H900	FUEL TANK CAP COMP.	1.....	INCLUDES ITEM W/#
22	17672Z4H000	FILTER, FUEL	1	
27	17510Z5K000ZA	TANK, COMP. FUEL, NH1 (BLACK)	1	

HONDA GX270UT2SMXC/SCM ENG. — FLYWHEEL ASSY.

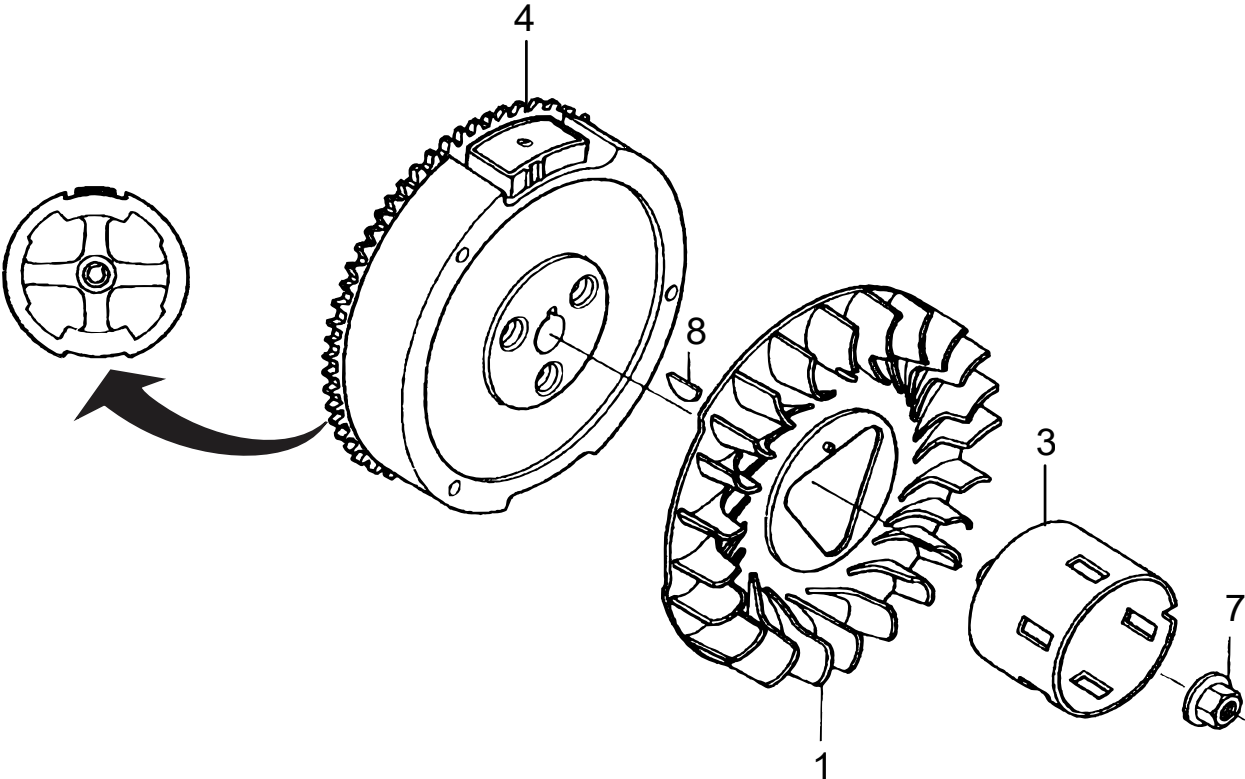

HONDA GX270UT2SMXC/SCM ENG. — FLYWHEEL ASSY.

<u>NO.</u>	<u>PART NO.</u>	<u>PART NAME</u>	<u>QTY.</u>	<u>REMARKS</u>
1	19511ZE2000	FAN, COOLING	1	
3	28451ZE2W01	PULLEY, STARTER	1	
4	31110Z5K000	FLYWHEEL, COMP.	1	
7	90201ZE3V00	NUT, SPECIAL 16MM	1	
8	90741ZE2000	KEY, SPECIAL WOODRUFF 25X18	1	

HONDA GX270UT2SMXC/SCM ENG. — IGNITION COIL ASSY.

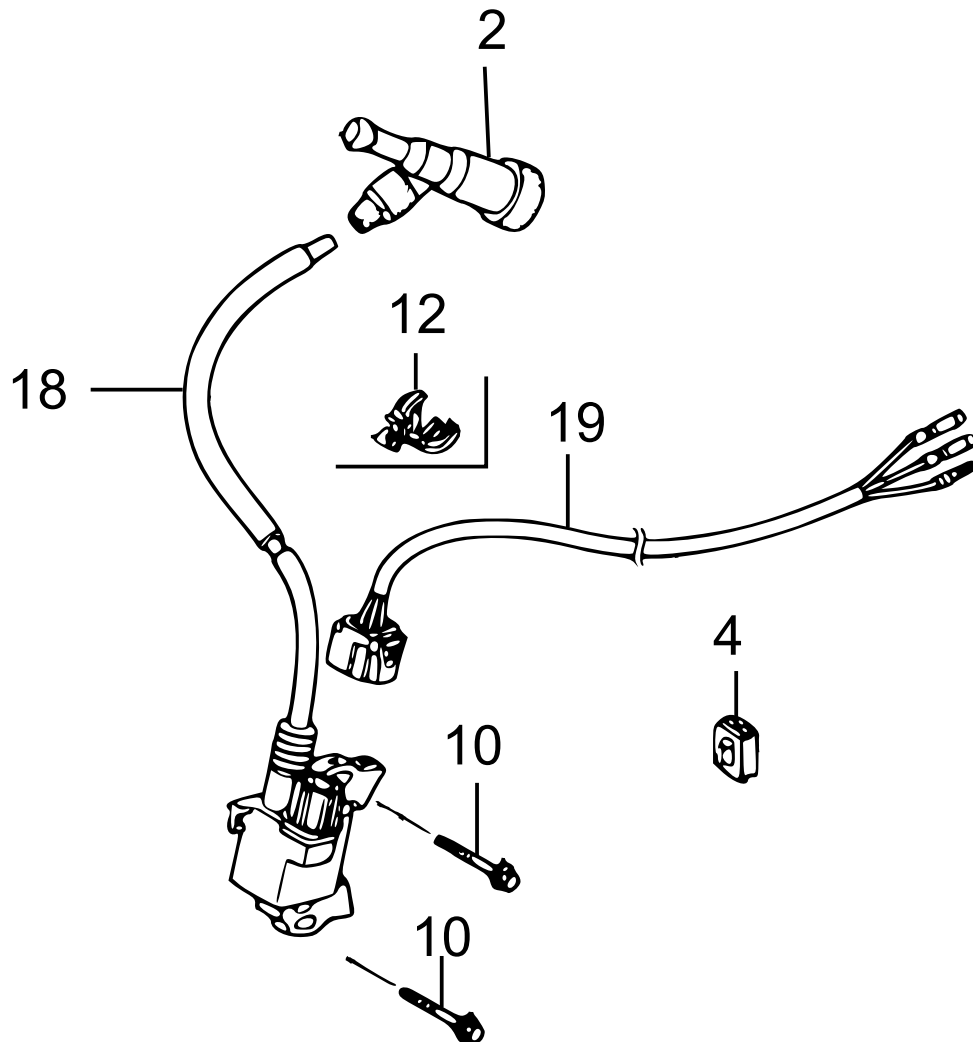

HONDA GX270UT2SMXC/SCM ENG. — IGNITION COIL ASSY.

<u>NO.</u>	<u>PART NO.</u>	<u>PART NAME</u>	<u>QTY.</u>	<u>REMARKS</u>
2◆	30700Z1C811	CAP ASSY., NOISE SUPPRESOR	1	
2◇	30700Z1C813	CAP ASSY., NOISE SUPPRESOR	1	
4	31512ZE2000	GROMMET, CORD	1	
10	90015883000	FLANGE BOLT 6X28	2	
12	90684ZA0601	CLIP, HARNESS	1	
18	30500Z5K003	COIL ASSY., IGNITION	1	
19	32110Z5K000	HARNESS ASSY., E/G WIRE	1	

NOTICE

◆ GX270UT2SMXC

◇ GX270UT2SCM

HONDA GX270UT2SMXC/SCM ENG. — CONTROL ASSY.

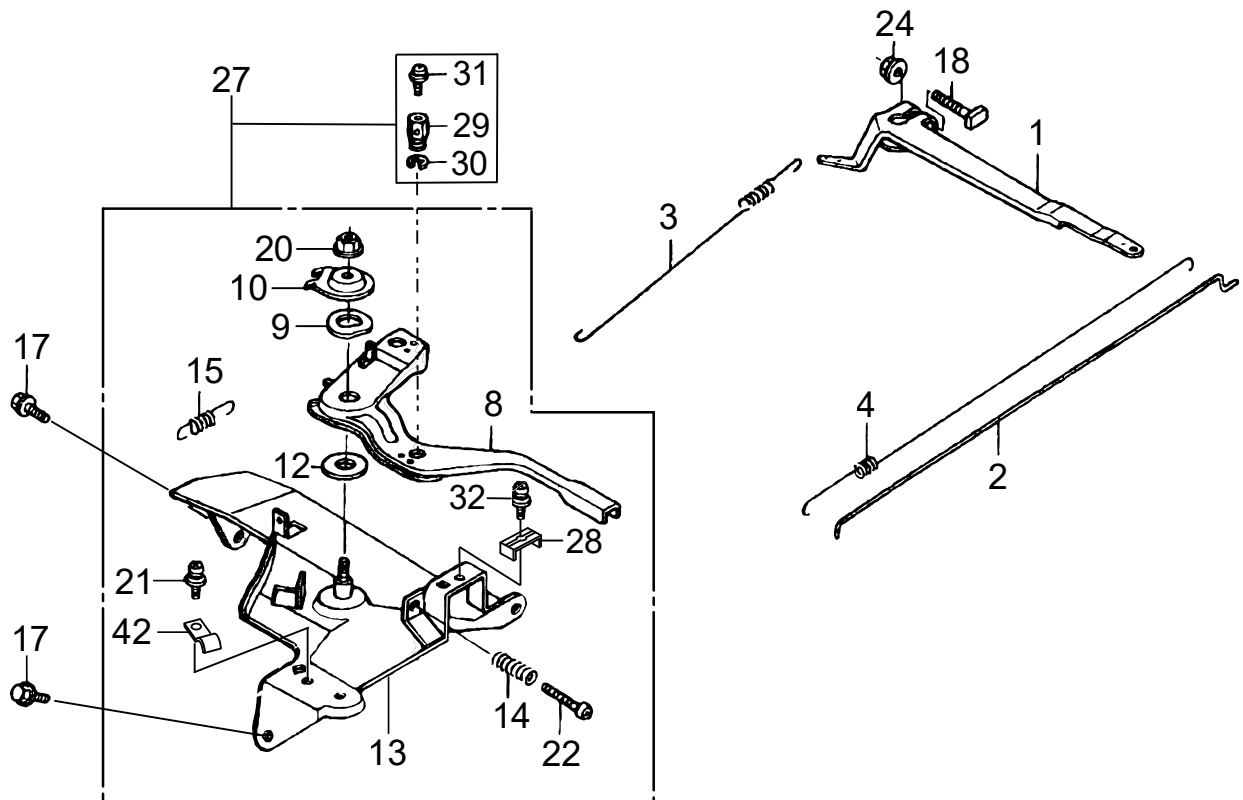

HONDA GX270UT2SMXC/SCM ENG. — CONTROL ASSY.

NO.	PART NO.	PART NAME	QTY.	REMARKS
1	16551ZE2000	ARM, GOVERNOR	1	
2	16555ZE2000	ROD, GOVERNOR	1	
3	16561ZE2000	SPRING, GOVERNOR	1	
4◆	16562ZE2000	SPRING, THROTTLE RETURN	1	
4◇	16562Z1D780	SPRING, THROTTLE RETURN	1	
8\$%	16571ZE2W00	LEVER, CONTROL	1	
9\$%	16574ZE1000	LEVER SPRING	1	
10\$%	16575ZE2W00	WASHER, CONTROL LEVER	1	
12\$%	16578ZE1000	SPACER, CONTROL LEVER	1	
13\$	16580Z5K000	BASE COMP., CONTROL	1	
13%	16580Z1D780	BASE COMP., CONTROL	1	
14\$%	16584883300	ADJUSTING SPRING	1	
15\$%	16592883310	SPRING, CABLE RETURN	1	
17	90013883000	FLANGE BOLT 6X12	2	
18	90015Z5T000	BOLT, GOVERNOR ARM	1	
20\$%	90114SA0000	LOCK NUT 6MM	1	
21%	0202005T125	SCREW, PAN 5X15 SS	1	REPLACES P/N 93500050160A
22\$%	93500050280A	SCREW, PAN 5X28	1	
24	9405006000	FLANGE NUT 6MM	1	
27◆	16570Z5K308	CONTROL ASSY/REMOTE.....	1	INCLUDES ITEMS W/\$
27◇	16500Z1D307	CONTROL ASSY/REMOTE.....	1	INCLUDES ITEMS W/%
28\$	16576891000	HOLDER, CABLE	1	
29\$	16594883010	HOLDER, WIRE	1	
30\$	90605230000	CIR CLIP	1	
31\$	0043504060	SCREW 4X6	1	REPLACES P/N 93500040060H
32\$	0202005T125	SCREW 5X16	1	REPLACES P/N 93500050160A
42%	16582Z1D780	HOLDER, CONTROL CABLE	1	

NOTICE

- ◆ GX270UT2SMXC
- ◇ GX270UT2SCM

HONDA GX270UT2SMXC/SCM ENG. — ENGINE DECAL ASSY.

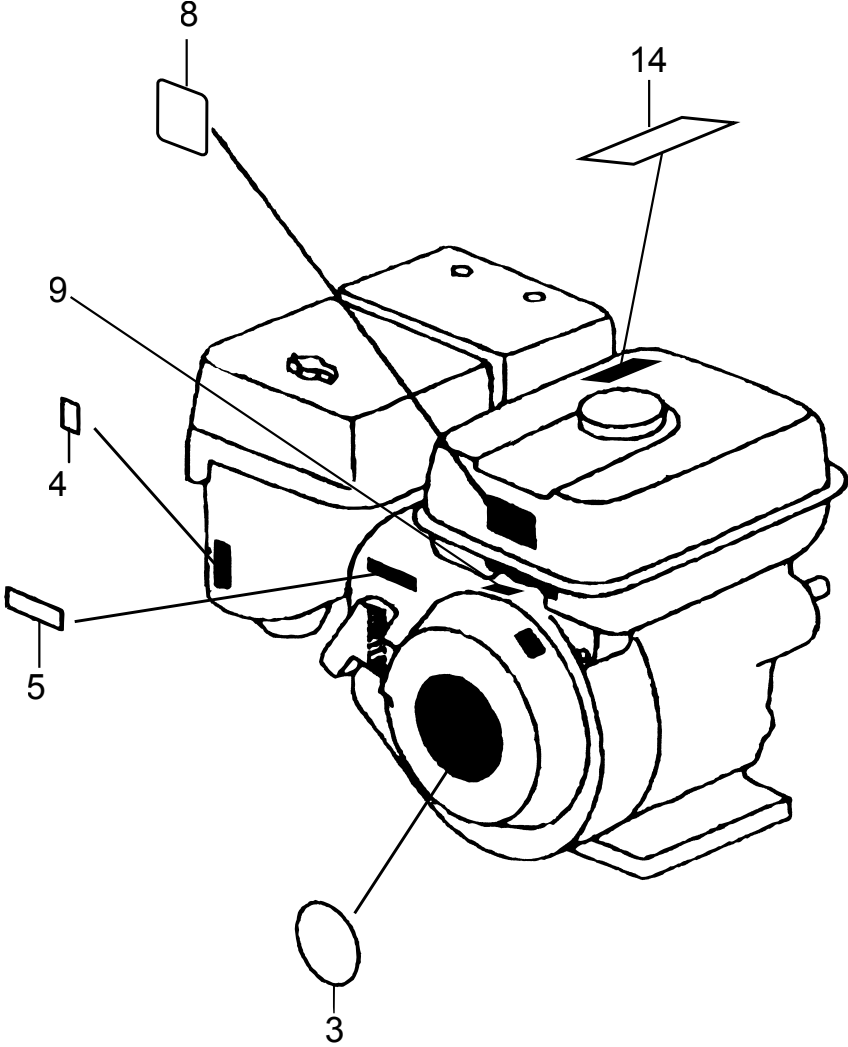

HONDA GX270UT2SMXC/SCM ENG. — ENGINE DECAL ASSY.

<u>NO.</u>	<u>PART NO.</u>	<u>PART NAME</u>	<u>QTY.</u>	<u>REMARKS</u>
3	87521Z5K000	EMBLEM	1	
4◆	87528Z5T000	MARK, CHOKE (GRAY)	1	
4◇	87528Z4M000	MARK, CHOKE	1	
5	87532ZH7000	MARK, THROTTLE INDICATION	1	
8◆	87535ZE1841	MARK, AIR CLEANER	1	
9	87516Z4H010	MARK, OP-CAUTION	1	
14◆	87539Z01000	MARK, EX. CAUTION	1	
14◇	87539Z0J000	MARK, EX. CAUTION/PICTO	1	

NOTICE

- ◆ GX270UT2SMXC
- ◇ GX270UT2SCM

PARTS MANUAL

HERE'S HOW TO GET HELP

PLEASE HAVE THE MODEL AND SERIAL
NUMBER ON-HAND WHEN CALLING

UNITED STATES

Multiquip Inc.

(310) 537- 3700
6141 Katella Avenue Suite 200
Cypress, CA 90630
E-MAIL: mq@multiquip.com
WEBSITE: www.multiquip.com

CANADA

Multiquip

(450) 625-2244
4110 Industriel Boul.
Laval, Quebec, Canada H7L 6V3
E-MAIL: infocanada@multiquip.com

UNITED KINGDOM

Multiquip (UK) Limited Head Office

0161 339 2223
Unit 2, Northpoint Industrial Estate,
Globe Lane,
Dukinfield, Cheshire SK16 4UJ
E-MAIL: sales@multiquip.co.uk

© COPYRIGHT 2022, MULTIQUIP INC.

Multiquip Inc, the MQ logo are registered trademarks of Multiquip Inc. and may not be used, reproduced, or altered without written permission. All other trademarks are the property of their respective owners and used with permission.

This manual MUST accompany the equipment at all times. This manual is considered a permanent part of the equipment and should remain with the unit if resold.

The information and specifications included in this publication were in effect at the time of approval for printing. Illustrations, descriptions, references and technical data contained in this manual are for guidance only and may not be considered as binding. Multiquip Inc. reserves the right to discontinue or change specifications, design or the information published in this publication at any time without notice and without incurring any obligations.

Your Local Dealer is:

