

PARTS MANUAL



Mikasa SERIES
MODEL MVH508DE
REVERSIBLE PLATE COMPACTOR
(HATZ 1D90E DIESEL ENGINE)

Revision #4 (05/11/26)

To find the latest revision of this publication or associated operation manual, visit our website at: www.multiquip.com



THIS MANUAL MUST ACCOMPANY THE EQUIPMENT AT ALL TIMES.

**MVH508DE Reversible
Plate Compactor**

Explanation of Code in Remarks Column..... 4
Suggested Spare Parts 5

Component Drawings

Nameplate and Decals Assembly..... 6-7
Vibrating Plate Assembly 8-9
Vibrator Assembly..... 10-11
Base and Engine Assembly 12-15
Electric Device Assembly 16-19
Wire Harness Assembly 20-21
Battery Assembly 22-23
Control Assembly..... 24-27
Hydraulic Hand Pump Assembly 28-29
Engine Service Parts 30-31

NOTICE
Specifications and part numbers are subject to change
without notice.

EXPLANATION OF CODE IN REMARKS COLUMN

The following section explains the different symbols and remarks used in the Parts section of this manual. Use the help numbers found on the back page of the manual if there are any questions.

NOTICE

The contents and part numbers listed in the parts section are subject to change without notice. Multiquip does not guarantee the availability of the parts listed.

SAMPLE PARTS LIST

NO.	PART NO.	PART NAME	QTY.	REMARKS
1	12345	BOLT	1	INCLUDES ITEMS W/%
2%		WASHER, 1/4 IN.		NOT SOLD SEPARATELY
2%	12347	WASHER, 3/8 IN. ...	1	MQ-45T ONLY
3	12348	HOSE	A/R	MAKE LOCALLY
4	12349	BEARING	1	S/N 2345B AND ABOVE

NO. Column

Unique Symbols — All items with same unique symbol (@, #, +, %, or >) in the number column belong to the same assembly or kit, which is indicated by a note in the “Remarks” column.

Duplicate Item Numbers — Duplicate numbers indicate multiple part numbers, which are in effect for the same general item, such as different size saw blade guards in use or a part that has been updated on newer versions of the same machine.

NOTICE

When ordering a part that has more than one item number listed, check the remarks column for help in determining the proper part to order.

PART NO. Column

Numbers Used — Part numbers can be indicated by a number, a blank entry, or TBD.

TBD (To Be Determined) is generally used to show a part that has not been assigned a formal part number at the time of publication.

A blank entry generally indicates that the item is not sold separately or is not sold by Multiquip. Other entries will be clarified in the “Remarks” Column.

QTY. Column

Numbers Used — Item quantity can be indicated by a number, a blank entry, or A/R.

A/R (As Required) is generally used for hoses or other parts that are sold in bulk and cut to length.

A blank entry generally indicates that the item is not sold separately. Other entries will be clarified in the “Remarks” Column.

REMARKS Column

Some of the most common notes found in the “Remarks” Column are listed below. Other additional notes needed to describe the item can also be shown.

Assembly/Kit — All items on the parts list with the same unique symbol will be included when this item is purchased.

Indicated by:

“INCLUDES ITEMS W/(unique symbol)”

Serial Number Break — Used to list an effective serial number range where a particular part is used.

Indicated by:

“S/N XXXXX AND BELOW”

“S/N XXXX AND ABOVE”

“S/N XXXX TO S/N XXX”

Specific Model Number Use — Indicates that the part is used only with the specific model number or model number variant listed. It can also be used to show a part is NOT used on a specific model or model number variant.

Indicated by:

“XXXXX ONLY”

“NOT USED ON XXXX”

“Make/Obtain Locally” — Indicates that the part can be purchased at any hardware shop or made out of available items. Examples include battery cables, shims, and certain washers and nuts.

“Not Sold Separately” — Indicates that an item cannot be purchased as a separate item and is either part of an assembly/kit that can be purchased, or is not available for sale through Multiquip.

SUGGESTED SPARE PARTS

MVH508DE REVERSIBLE PLATE COMPACTOR

1 to 3 units

Qty.	P/N	Description
4.....	939010370.....	SHOCK ABSORBER
4.....	939010010.....	SHOCK ABSORB. STOPPER
2.....	070200483.....	V-BELT HDPF-5480
1.....	50384402.....	IGNITION SWITCH W/ KEYS
3.....	50404900.....	KEY, IGNITION SWITCH

NOTICE

Part numbers on this Suggested Spare Parts list may supersede/replace the part numbers shown in the following parts lists.

HATZ 1D90E DIESEL ENGINE

1 to 3 units

Qty.	P/N	Description
3.....	01480001.....	OIL FILTER ELEMENT
3.....	03795000.....	OIL SUCTION SIEVE
3.....	50387300.....	FUEL FILTER/SIEVE
3.....	40089401.....	IN-LINE FUEL FILTER
3.....	01493001.....	ELEMENT, AIR CLEANER
1.....	50385801.....	CAP, FUEL TANK

NAMEPLATE AND DECALS ASSY.

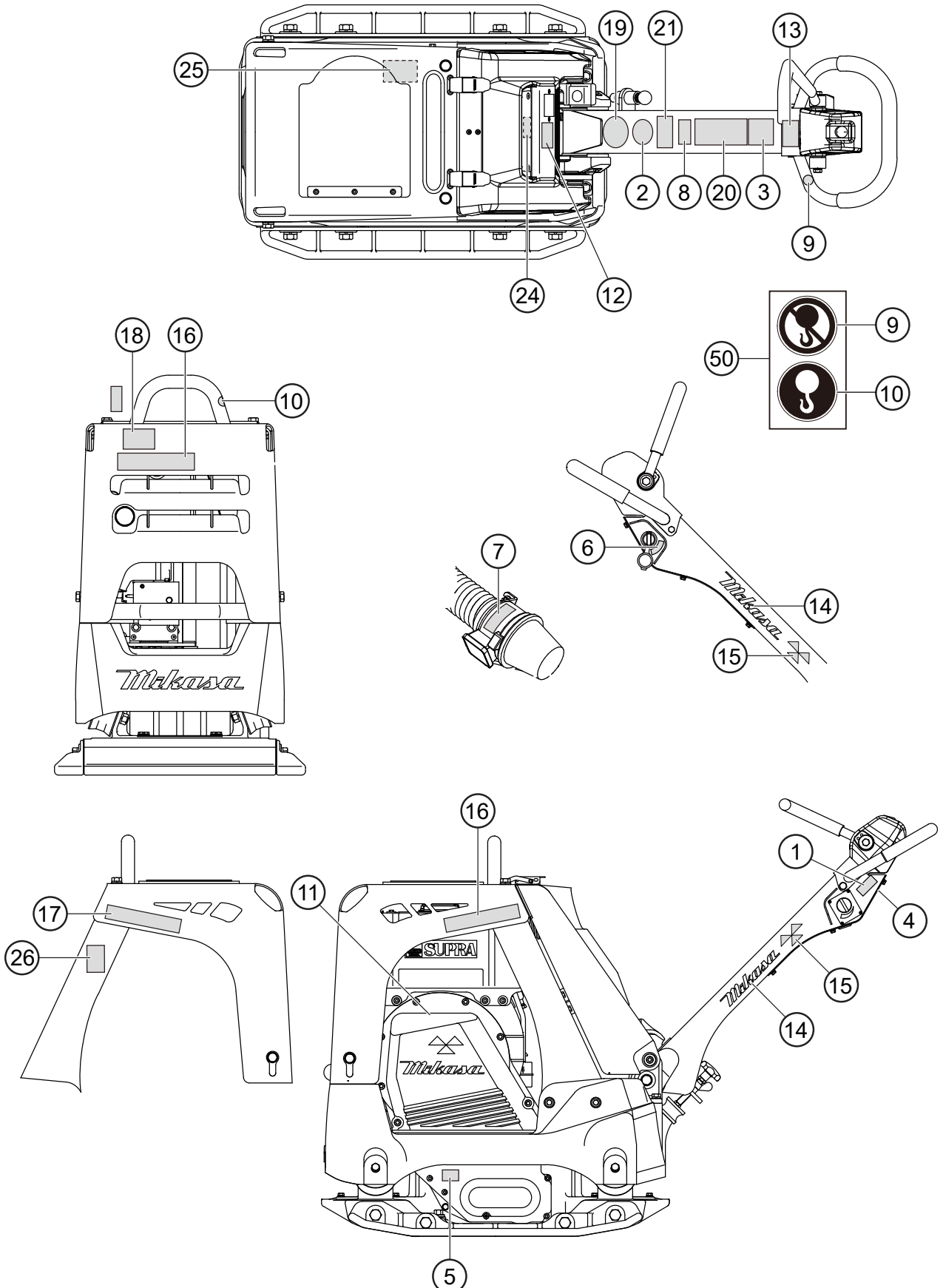

NAMEPLATE AND DECALS ASSY.

<u>NO.</u>	<u>PART NO.</u>	<u>PART NAME</u>	<u>QTY.</u>	<u>REMARKS</u>
1	920204580	DECAL; FULL THROTTLE/MVH	1	
2	920222810	LABEL, EAR PROTECTION	1	
3	920211060	DECAL; CAUTION, LEVER	1	
4	920211090	DECAL; SHELL TELLUS OIL 32	1	
5	920201950	DECAL; OIL SAE 10W-30	1	
6	920106760	DECAL; STOP-RUN-START	1	
7	920214200	DECAL; CAUTION CYCLONE	1	
8	920214100	DECAL; E/G FIRE WARNING	1	
9#	920900090	DECAL; DO NOT LIFT.....	1	REPLACES P/N 920214730
10#	920900090	DECAL; LIFTING POSITION.....	1	REPLACES P/N 920214740
11	920217700	DECAL; V-BELT HDPF-5480	1	
12	920218150	DECAL; E/G RPM 2400	1	
13	920210670	DECAL; EC NOISE REQ. LWA	1	
14	920217130	DECAL; MIKASA MARK (W) 200L	2	
15	920217110	DECAL; MIKASA MARK 35X70	2	
16	920217810	DECAL; MODEL (R)	2	
17	920217820	DECAL; MODEL (L)	1	
18	920201580	DECAL; MQ MARK 71X55	1	
19	920224750	DECAL; MQ, 3 YEARS WARRANTY	1	
20	920218390	DECAL; CAUTION	1	
21	920222240	DECAL; WARNING PROPOSITION 65	1	
24	920217890	DECAL; MODEL MVH-508	1	
25		PLATE, SERIAL NO.....	1	CONTACT MQ PARTS DEPT.
26	920224940	DECAL; CAUTION (NO WASH ECU)	1	
50	920900180	DECAL SET, TWO KINDS.....	1	INCLUDES ITEMS W/#

VIBRATING PLATE ASSY.

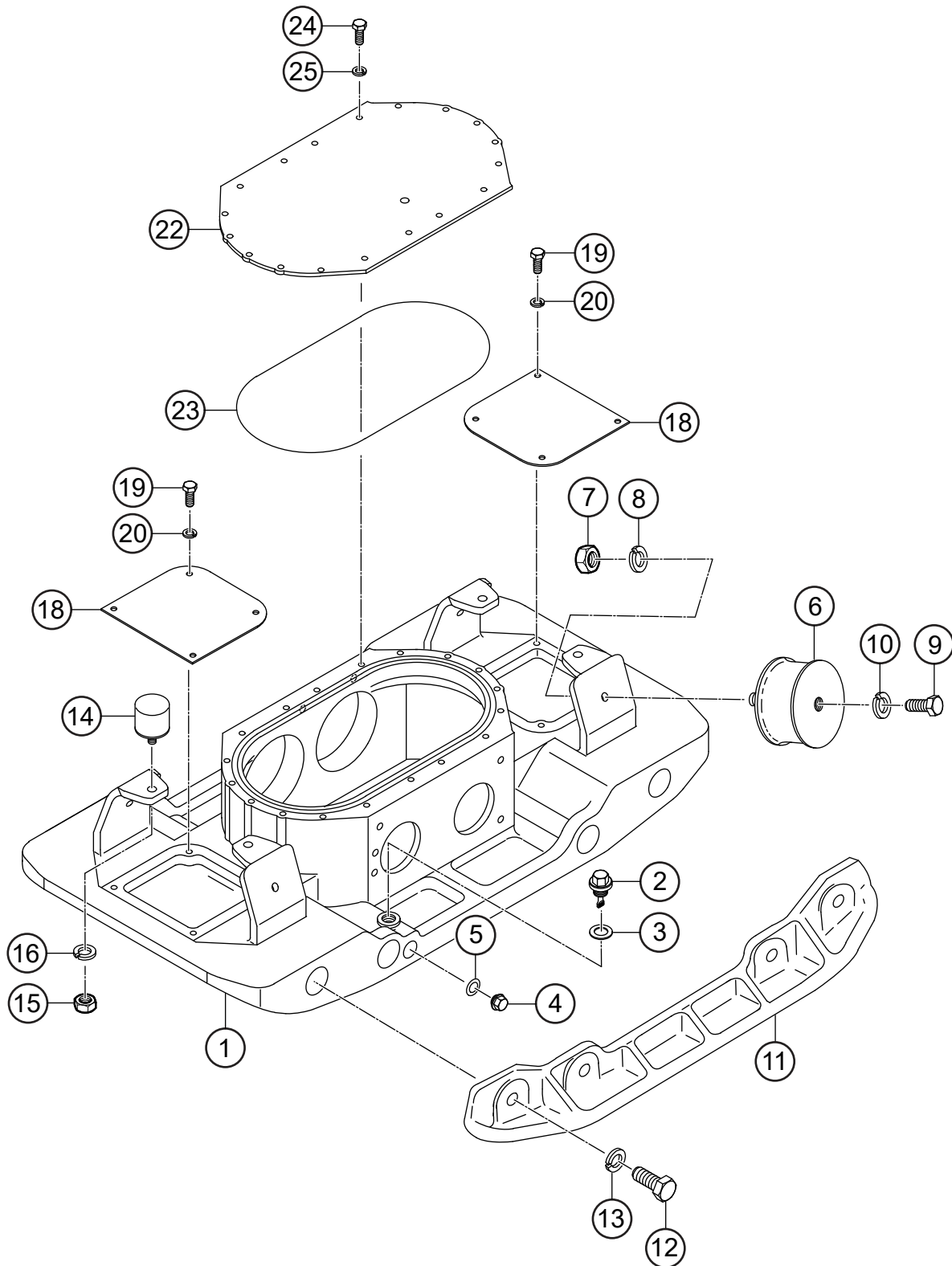

VIBRATING PLATE ASSY.

<u>NO.</u>	<u>PART NO.</u>	<u>PART NAME</u>	<u>QTY.</u>	<u>REMARKS</u>
1	468121201	VIBRATING PLATE	1	
2	465460670	OIL GAUGE	1	
3	953402930	COPPER PACKING	1	
4	953405270	PLUG	1	
5	953405260	PACKING	1	
6	939010370	SHOCK ABSORBER	4	REPLACES P/N 939010392
7	020316130	NUT	4	
8	030216400	WASHER, LOCK	4	
9	001221635	BOLT	4	
10	030216400	WASHER, LOCK	4	
11	452990	EXTENSION PLATES 3" (SET)	1	2 PC = 1 SET REPLACES P/N 467219050
12	012218050	BOLT	8	REPLACES P/N 001221850
13	58407	WASHER, LOCK	8	REPLACES P/N 030218460
14	939010010	SHOCK ABSORBER STOPPER	4	
15	020310080	NUT	4	
16	030210250	WASHER, LOCK	4	
18	468352110	COVER, VIBRATING PLATE	2	
19	001220820	BOLT	8	
20	030208200	WASHER, LOCK	8	
22	467351790	COVER, VIBRATOR	1	
23	050103250	O-RING	1	
24	001220820	BOLT	18	
25	030208200	WASHER, LOCK	18	

VIBRATOR ASSY.

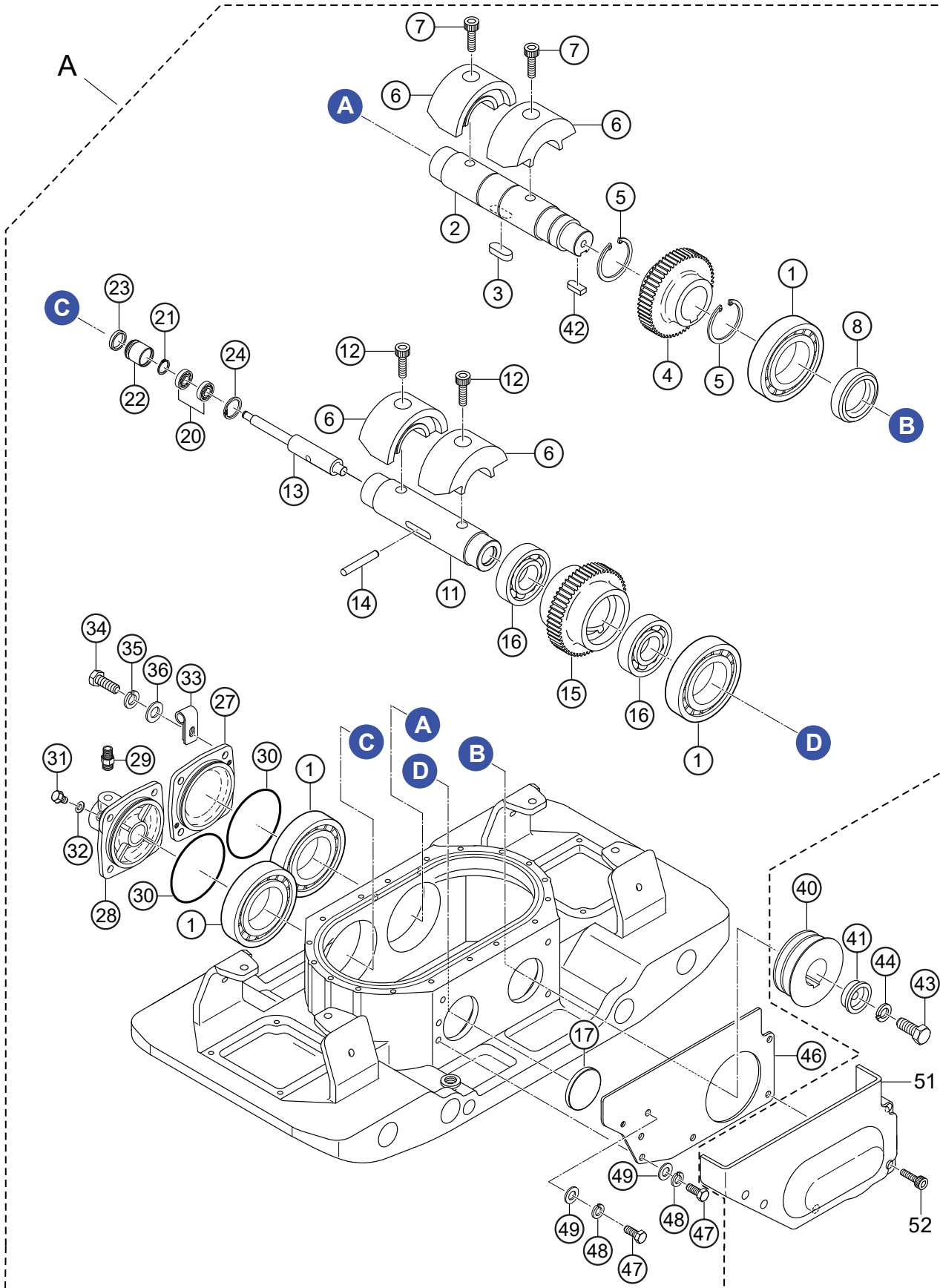

VIBRATOR ASSY.

<u>NO.</u>	<u>PART NO.</u>	<u>PART NAME</u>	<u>QTY.</u>	<u>REMARKS</u>
A	469910032	VIBRATING PLATE ASSEMBLY	1	
1	047920120	ROLLER BEARING	4	REPLACES P/N 047920060
2	467910070	ROTARY SHAFT, DRIVE	1	
3	951405370	KEY	1	
4	456327150	GEAR, DRIVE	1	
5	080200550	STOP RING	2	
6	469352310	ECCENTRIC ROTATOR	4	
7	009120301	SOCKET HEAD BOLT	2	
8	060405040	OIL SEAL	1	
11	456337670	ROTARY SHAFT, DRIVEN	1	
12	009120302	SOCKET HEAD BOLT	2	
13	456337380	PISTON ROD	1	
14	456010010	KNOCK PIN	1	
15	467351910	GEAR, DRIVEN	1	
16	040006911	BEARING	2	
17	953010030	SEAL CAP	1	
20	042006000	BEARING	2	REPLACES P/N 042506000
21	0080000010	STOP RING	1	REPLACES P/N 080200100
22	455435051	PISTON	1	
23	455010070	PACKING	1	
24	080100260	STOP RING	1	
27	467352540	BEARING COVER	1	
28	467219070	CYLINDER (R)	1	
29	954010020	CONNECTOR	1	
30	050101050	O-RING	2	
31	001720812	FLANGE BOLT	1	
32	953404600	COPPER PACKING	1	
33	959408880	CLIP	1	
34	0105091025	BOLT	8	REPLACES P/N 001221025
35	030210250	WASHER, LOCK	8	
36	031110160	WASHER, FLAT	8	
40	469358310	PULLEY	1	
41	468474700	WASHER	1	
42	951404970	KEY	1	
43	0105091025	BOLT	1	REPLACES P/N 001221235
44	030212300	WASHER, LOCK	1	
46	467351920	GUIDE, BELT COVER	1	
47	014208020	BOLT	2	REPLACES P/N 001220820
48	030208200	WASHER, LOCK	2	
49	0401450080	WASHER, FLAT	2	REPLACES P/N 031108160
51	469219032	BELT COVER, LOWER	1	
52	001520860	SOCKET HEAD BOLT	5	

BASE AND ENGINE ASSY.

<u>NO.</u>	<u>PART NO.</u>	<u>PART NAME</u>	<u>QTY.</u>	<u>REMARKS</u>
1	469121282	BASE	1	
2	918401203	ENGINE ASSY.,1D90 EPA4 F	1	
3	009120202	STUD BOLT	4	
4	030212300	WASHER, LOCK	4	
5	0039312000	NUT.....	4	REPLACES P/N 020312100
7	469352260	BELT COVER, INNER	1	
8	014210020	SOCKET HEAD BOLT	3	REPLACES P/N 001521020
9	030210250	WASHER, LOCK	3	
11	469218980	DUST COVER	1	
12	092006010	FLAT HEAD SCREW	6	
13	469474790	ENGINE SPACER, FRONT	1	
14	469474800	ENGINE SPACER, REAR	1	
15	469352390	CLUTCH ASSEMBLY	1	
16	951010130	KEY	1	
17	952401390	WASHER	1	
18	0105091025	BOLT	1	REPLACES P/N 001221025
19	030210250	WASHER, LOCK	1	
22	070200483	V-BELT, HDPF-5480	2	
24	457339571	STUB SHAFT	1	
25	011208030	BOLT	4	REPLACES P/N 001220830
26	030208200	WASHER, LOCK	4	
27	457336380	FAN	1	
28	001220820	BOLT	6	
29	030208200	WASHER, LOCK	6	
32	469218990	BELT COVER, OUTER	1	
33	469358300	DUST SPONGE, OUTER	1	
34	001521058	SOCKET HEAD BOLT	2	
35	001521045	SOCKET HEAD BOLT	5	
36	469474810	DUST SPONGE, INNER	1	
37	469352281	FRONT BUMPER	1	
38	001521435	SOCKET HEAD BOLT	2	
39	030214350	WASHER, LOCK	2	
40	469121291	FRONT COVER	1	
41	001221435	BOLT	4	
42	030214350	WASHER, LOCK	4	
43	031114260	WASHER, FLAT	4	
45	469219330	CENTER COVER	1	
46	001521440	SOCKET HEAD BOLT	4	
47	031114260	WASHER, FLAT	2	
48	030214350	WASHER, LOCK	4	
49	020314110	NUT	2	
51	468466890	RUBBER COVER, UPPER	1	
52	467466760	STOPPER, COVER	1	
53	009120424	SOCKET HEAD BOLT	3	
54	617465130	COLLAR	3	
55	030206150	WASHER, LOCK	3	
56	022710607	NYLON NUT	3	

BASE AND ENGINE ASSY. (CONT'D.)

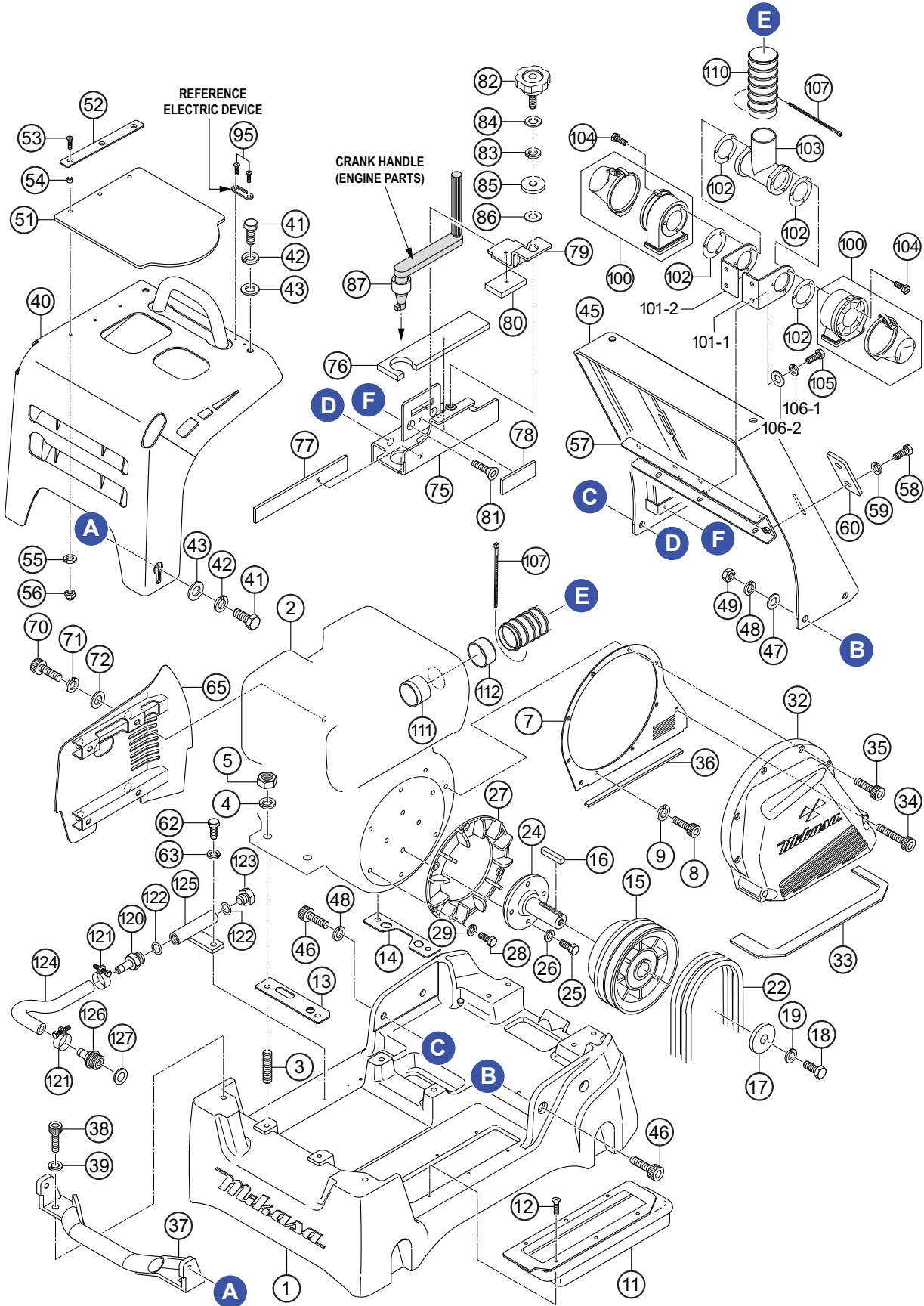

BASE AND ENGINE ASSY. (CONT'D.)

<u>NO.</u>	<u>PART NO.</u>	<u>PART NAME</u>	<u>QTY.</u>	<u>REMARKS</u>
57	469352890	CLEANER STAY	1	
58	011208025	BOLT	4	REPLACES P/N 001220825
59	030208200	WASHER, LOCK	4	
60	467467580	PLATE, CLEANER STAY	2	
62	001220820	BOLT	1	
63	030208200	WASHER, LOCK	1	
65	469219013	SIDE COVER	1	
70	001521251	SOCKET HEAD BOLT	4	
71	030212300	WASHER, LOCK	4	
72	031112230	WASHER, FLAT	4	
75	469219120	HOLDER, CRANK HANDLE	1	
76	469467320	POLYURETHANE SEAT	1	
77	469467310	POLYURETHANE SEAT	1	
78	469467300	POLYURETHANE SEAT	1	
79	469352530	HOLDER, CRANK HANDLE	1	
80	469467330	POLYURETHANE SEAT	1	
81	009120408	SUNK HEAD BOLT	2	
82	959406961	GRIP BOLT	1	
83	030210250	WASHER, LOCK	1	
84	031110160	WASHER, FLAT	1	
85	952403450	WASHER	1	
86	952008940	SEAL WASHER	1	
87	469467190	RUBBER PIPE	1	
95	009120420	SOCKET HEAD BOLT	4	
100	466218080	AIR CLEANER, CYCLONE	2	
100-1	466010030	CHAMBER, CYCLONE	2	
100-2	466010020	DUST POT	2	
101-1	469467550	CYCLONE STAY, LEFT	1	
101-2	469467560	CYCLONE STAY RIGHT	1	
102	466462850	GASKET, AIR INTAKE	4	
103	469219020	JOINT, CYCLONE CLEANER	1	
104	009110057	SOCKET HEAD BOLT	6	
105	001220820	BOLT	4	
106-1	030208200	WASHER, LOCK	4	
106-2	0401450080	WASHER, FLAT	4	REPLACES P/N 031108160
107	506010060	CLAMP	2	
110	466348590	DUCT HOSE	1	
111	469467010	INTAKE PIPE	1	
112	466462840	DUCT GROMMET	1	
120	2556390111	UNION, DRAIN	1	REPLACES P/N 954407310
121	954410140	HOSE CLAMP	2	
122	953410290	GASKET	2	
123	953410280	PLUG	1	
124	954410150	DRAIN HOSE	1	
125	464457380	DRAIN JOINT	1	
126	465459670	OIL DRAIN	1	
127	50001600	JOINT	1	

ELECTRIC DEVICE ASSY.

<u>NO.</u>	<u>PART NO.</u>	<u>PART NAME</u>	<u>QTY.</u>	<u>REMARKS</u>
18	469121300	REAR COVER	1	
23	001220820	BOLT	1	
24	030208200	WASHER, LOCK	1	
25	0401450080	WASHER, FLAT	1	REPLACES P/N 031108160
26	959408920	CLIP	1	
28	404433430	RUBBER	2	
29	001521051	SOCKET HEAD BOLT	2	
30	030210250	WASHER, LOCK	2	
31	952401660	WASHER	2	
32	467467250	RUBBER WASHER	2	
33	417454420	COLLAR	2	
35	469467470	CATCH CLIP	2	
36	009120421	SOCKET HEAD BOLT	4	
40	469352340	BRACKET, STOPPER	1	
41	939010360	STOPPER RUBBER	2	
42	020108060	NUT.....	2	REPLACES P/N 020308060
43	030208200	WASHER, LOCK	2	
50	506010070	CLAMP	6	
51	467352050	PANEL, REAR COVER	1	
53	009110091	SOCKET HEAD SCREW	4	
54	031106100	WASHER, FLAT	4	REPLACES P/N 031106100
55	030206150	WASHER, LOCK	4	
56	022710607	NYLON NUT	4	
58	467469300	RUBBER STRING HOLDER	2	
59	467469310	RUBBER STRING	2	
74	470468770	PROTECTION COVER, SWITCH	1	
74-1	507010110A	ZIP TIE	1	REPLACES P/N 507010110
78	465459680	RELAY CABLE, BUZZER	1	
79	959026022	CORRUGATE TUBE	1	
80	959020014	SPIRAL TUBE	1	
82	469352400	PANEL WITH BUZZER	1	
83	001220635	BOLT	1	
84	030206150	WASHER, LOCK	1	
85	001520530	SOCKET HEAD BOLT	2	
86	506010070	CLAMP	1	
90	009110072	PAN HEAD SCREW	2	
91	952407930	COLLAR	2	
92	022710506	NYLON NUT	2	
93	030205130	WASHER, LOCK	2	
94	58151	WASHER, FLAT	2	REPLACES P/N 031105080
96	955301020	TACHOMETER/HOUR METER	1	
97	469467040	RESISTOR, TACHOMETER	1	
98	955409080	FIXED BASE, WIRING	2	
99	506010070	CLAMP	2	
100	959021813	SPIRAL TUBE	1	
101	50384402	IGNITION SWITCH ASSY.	1	
101-1	50404900	KEY, IGNITION SWITCH	1	

ELECTRIC DEVICE ASSY. (CONT'D.)

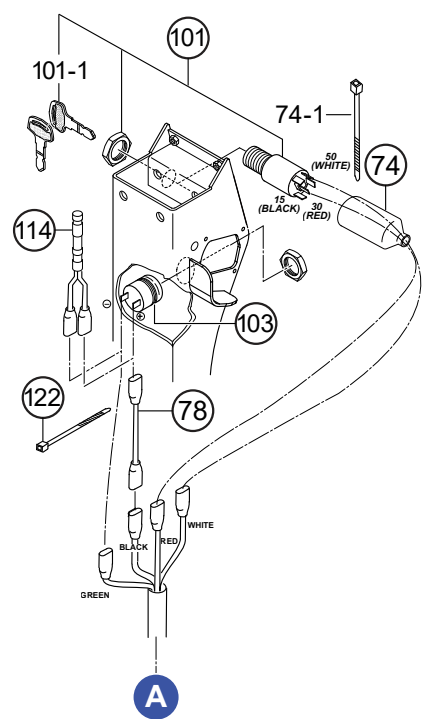
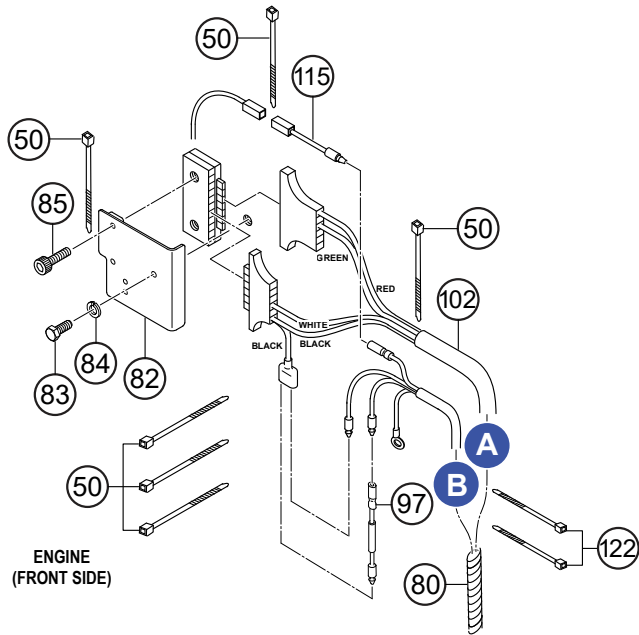
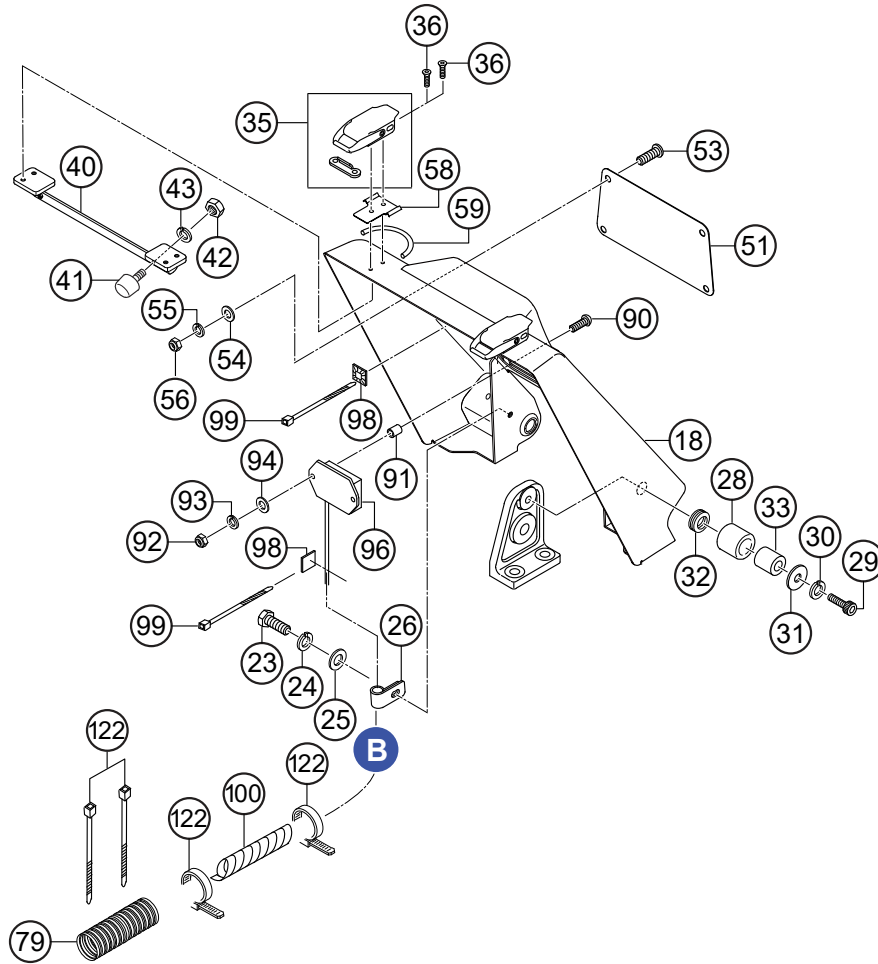

ELECTRIC DEVICE ASSY. (CONT'D.)

<u>NO.</u>	<u>PART NO.</u>	<u>PART NAME</u>	<u>QTY.</u>	<u>REMARKS</u>
102	469358590	WIRE HARNESS, ENGINE	1	
103	50465100	BUZZER	1	
114	467358580	WIRE HARNESS, BUZZER	1	
115	469475150	WIRE HARNESS	1	
122	506010070	CLAMP	5	

WIRE HARNESS ASSY.

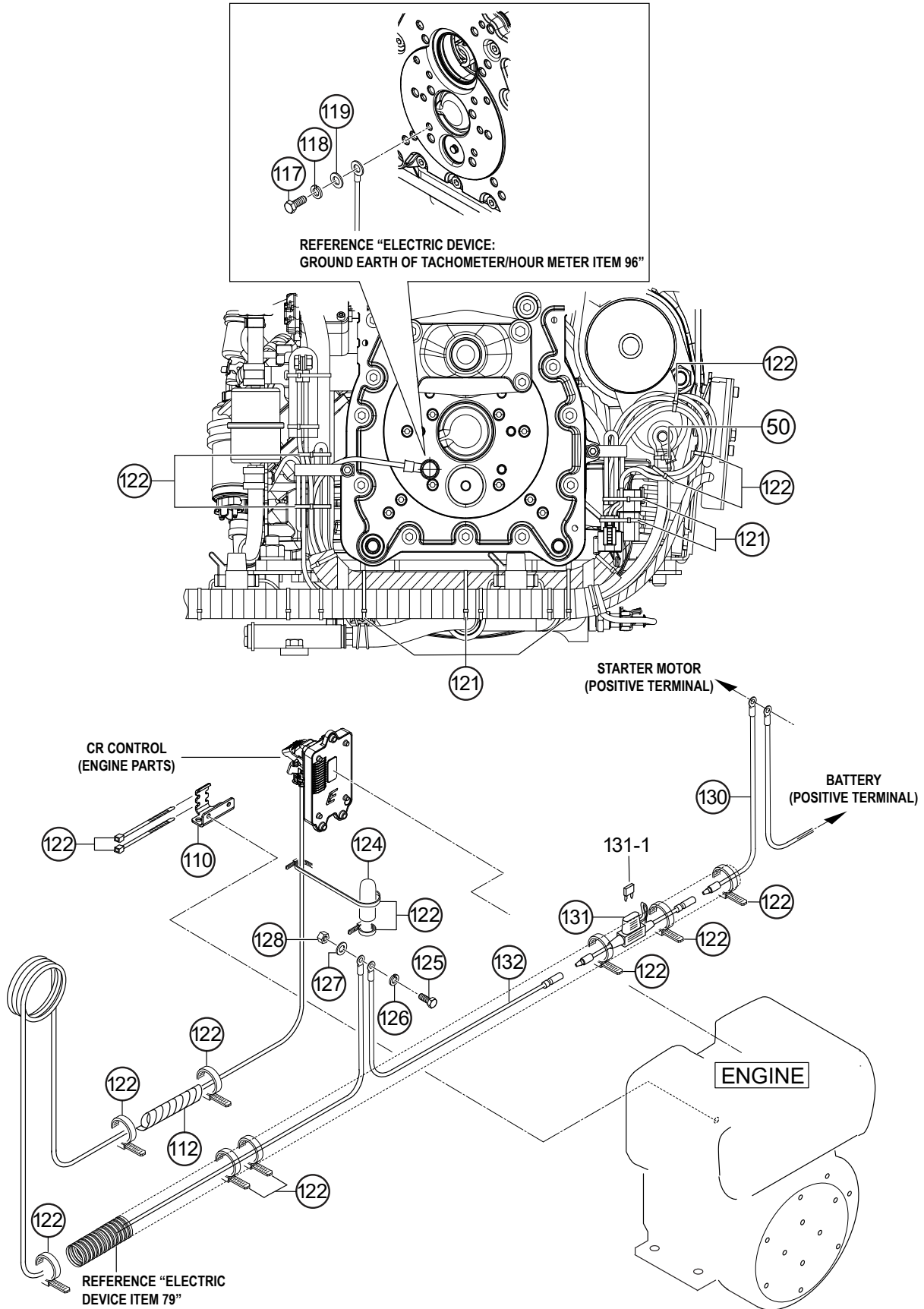

WIRE HARNESS ASSY.

<u>NO.</u>	<u>PART NO.</u>	<u>PART NAME</u>	<u>QTY.</u>	<u>REMARKS</u>
50	506010070	CLAMP	1	
110	05678500	CABLE HOLDER	1	
112	955404273	SPIRAL TUBE	1	
117	011008015	BOLT	1.....	REPLACES P/N 001220815
118	030208200	WASHER, LOCK	1	
119	0401450080	WASHER, FLAT	1.....	REPLACES P/N 031108160
121	507010110A	ZIP TIE	5.....	REPLACES P/N 507010110
122	506010070	CLAMP	17	
124	467475260	TERMINAL CAP	1	
125	011006010	BOLT	1.....	REPLACES P/N 001220610
126	030206150	WASHER, LOCK	1	
127	952404470	WASHER, FLAT	1.....	REPLACES P/N 031106100
128	020106050	NUT.....	1.....	REPLACES P/N 020306050
130	467475250	RELAY CABLE, STARTER	1	
131	467358730	FUSE HOLDER, SENSOR	1	
131-1	467010040	FUSE, 30A SMALL	1	
132	467475240	RELAY CABLE, TERMINAL	1	

BATTERY ASSY.

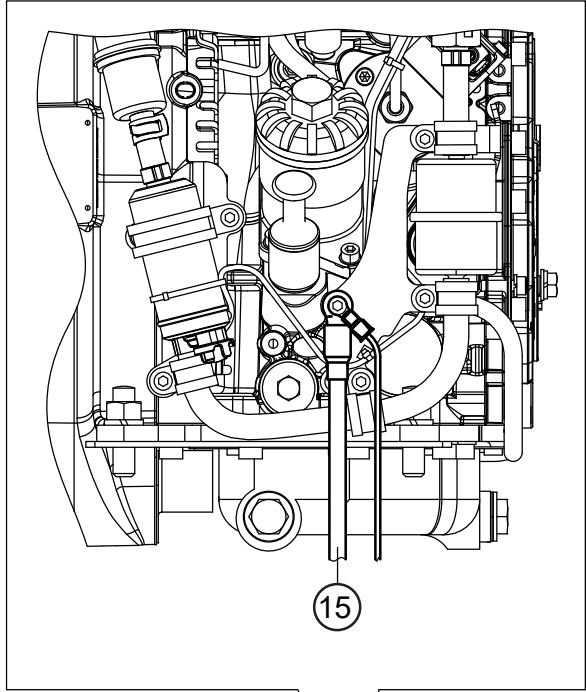

ENGINE
(REAR SIDE)
GROUND

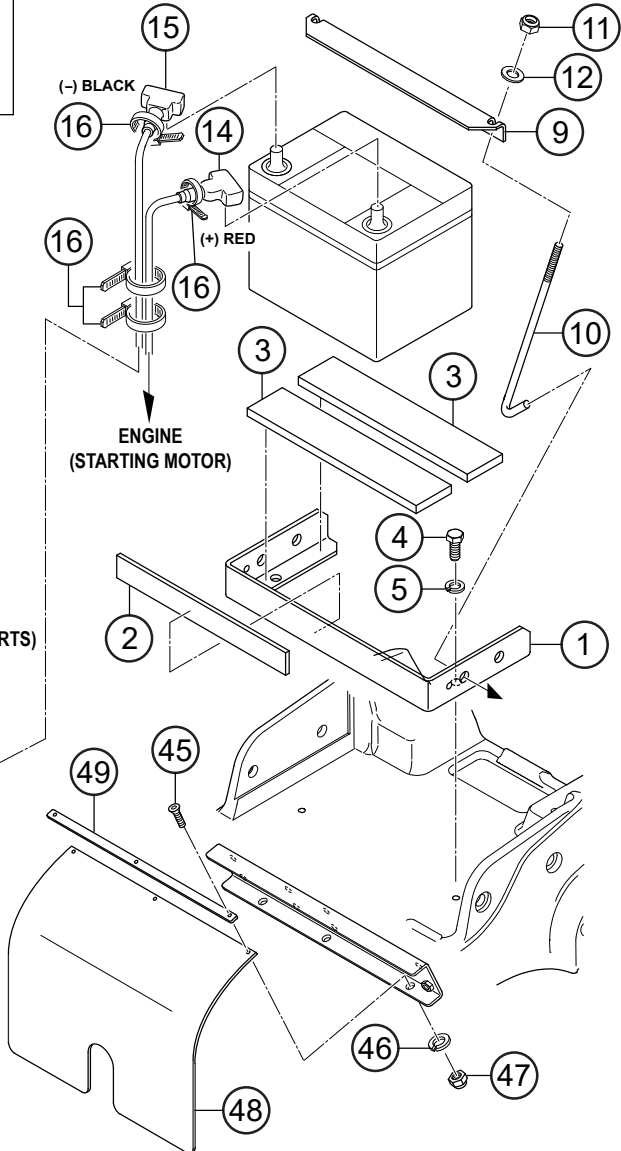
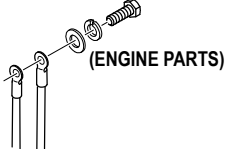
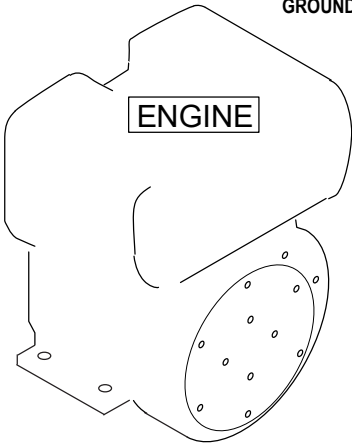

BATTERY ASSY.

<u>NO.</u>	<u>PART NO.</u>	<u>PART NAME</u>	<u>QTY.</u>	<u>REMARKS</u>
1	467218920	BATTERY HOLDER	1	
2	456447590	RUBBER PLATE	1	
3	456447600	RUBBER PLATE	2	
4	012210020	BOLT	2.....	REPLACES P/N 001221020
5	030210250	WASHER, LOCK	2	
9	464343740	HOLDER, BATTERY	1	
10	469467170	BOLT, BATTERY	2	
11	022710809	NYLON NUT	2	
12	0401450080	WASHER, FLAT	2.....	REPLACES P/N 031108160
14	955301030	BATTERY CABLE, POSITIVE	1	
15	955301040	BATTERY CABLE, NEGATIVE	1	
16	506010070	CLAMP	4	
45	001220520	BOLT	3	
46	030205130	WASHER, LOCK	3	
47	022710506	NYLON NUT	3	
48	467466930	RUBBER PLATE, BATTERY	1	
49	467466920	STOPPER, RUBBER PLATE	1	
110	05678500	CABLE HOLDER	1	
112	959020014	SPIRAL TUBE.....	1.....	REPLACES P/N 955404276

CONTROL ASSY.

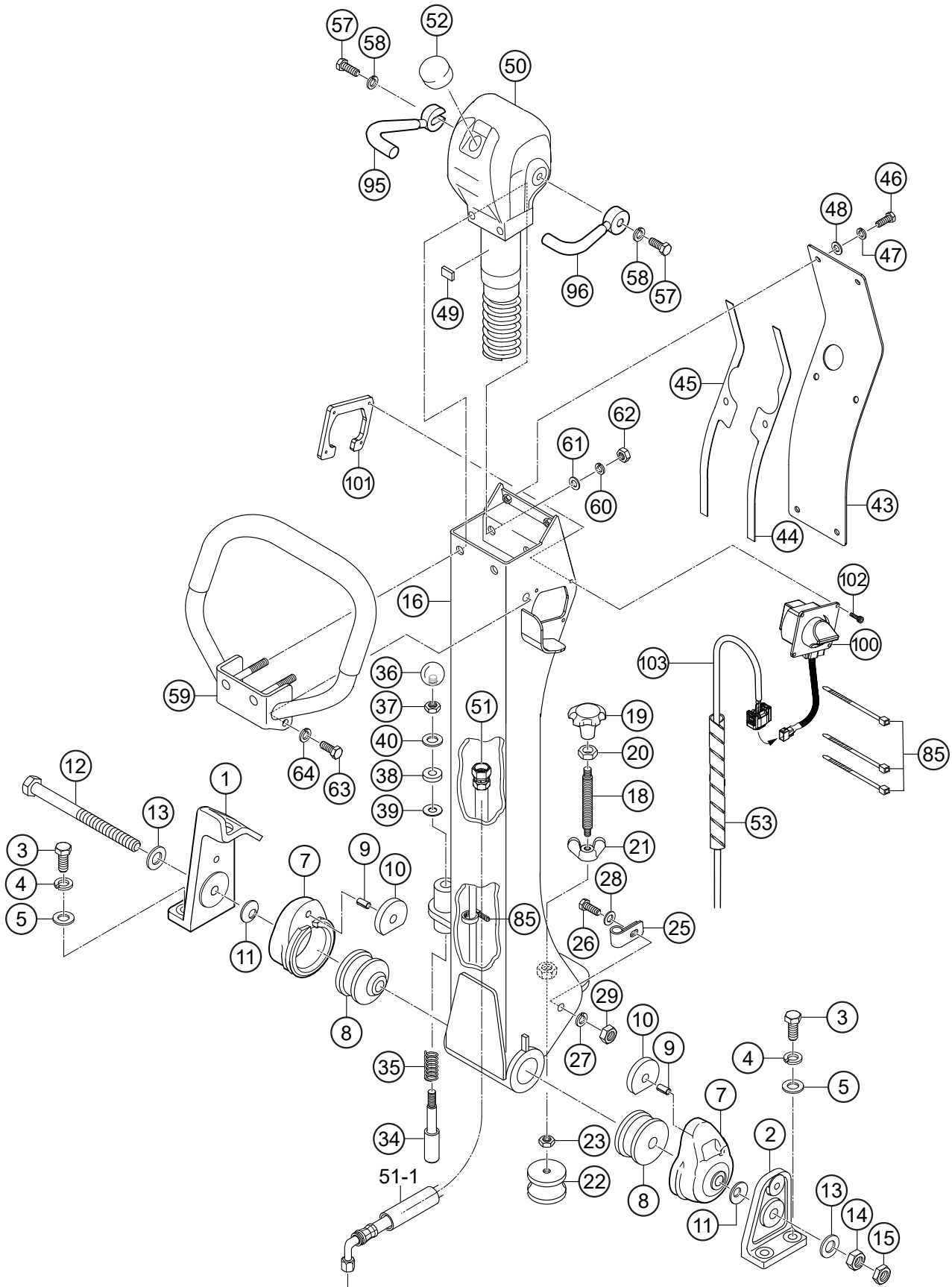

CONTROL ASSY.

<u>NO.</u>	<u>PART NO.</u>	<u>PART NAME</u>	<u>QTY.</u>	<u>REMARKS</u>
1	467351951	HANDLE BRACKET (R)	1	
2	467351960	HANDLE BRACKET (L)	1	
3	012212035	BOLT	4	REPLACES P/N 001221235
4	030212300	WASHER, LOCK	4	
5	031112230	WASHER, FLAT	4	
7	456336400	RUBBER COUPLING	2	
8	456449940	SHOCK ABSORBER	2	
9	025306016	SPRING PIN	2	REPLACES P/N 025406016
10	456449930	RUBBER PLATE	2	
11	032124400	CONICAL SPRING WASHER	2	
12	001221681	BOLT	1	
13	0401450160	WASHER, FLAT	2	REPLACES P/N 031116260
14	020316130	NUT	1	
15	020416100	NUT	1	
16	467123200	HANDLE BAR	1	
18	455434950	SPINDLE	1	
19	455010030	KNOB	1	
20	020412070	NUT	1	
21	022411635	WING NUT	1	
22	939010060	SHOCK ABSORBER	1	
23	020310080	NUT.....	1	REPLACES P/N 020410060
25	959408930	CLIP	1	
26	011206020	BOLT	1	REPLACES P/N 001220620
27	030206150	WASHER, LOCK	1	
28	952404470	WASHER, FLAT	1	REPLACES P/N 031106100
29	020106050	NUT.....	1	REPLACES P/N 020306050
34	501402870	HANDLE STOPPER	1	
35	501402880	SPRING HANDLE	1	
36	959403460	BALL GRIP	1	
37	020310080	NUT.....	1	REPLACES P/N 020410060
38	456449980	RUBBER PACKING	1	
39	953405260	PACKING 1/4	1	
40	031110160	WASHER, FLAT	1	
43	467358160	HANDLE COVER	1	
44	467475110	PACKING (L), HANDLE	1	
45	467475120	PACKING (R), HANDLE	1	
46	0105050616	BOLT	6	REPLACES P/N 001220615
47	030206150	WASHER, LOCK	6	
48	952404470	WASHER, FLAT	6	REPLACES P/N 031106100
49	464457930	RUBBER PIECE	1	
50	469219180	HYDRAULIC HAND PUMP	1	
51	954003100	OIL HOSE	1	
51-1	959409120	PROTECT TUBE	1	
52	458451630	BREATHER CAP	1	
53	959021813	SPIRAL TUBE	1	
57	012010030	BOLT	2	REPLACES P/N 001221030
58	030210250	WASHER, LOCK	2	

CONTROL ASSY. (CONT'D.)

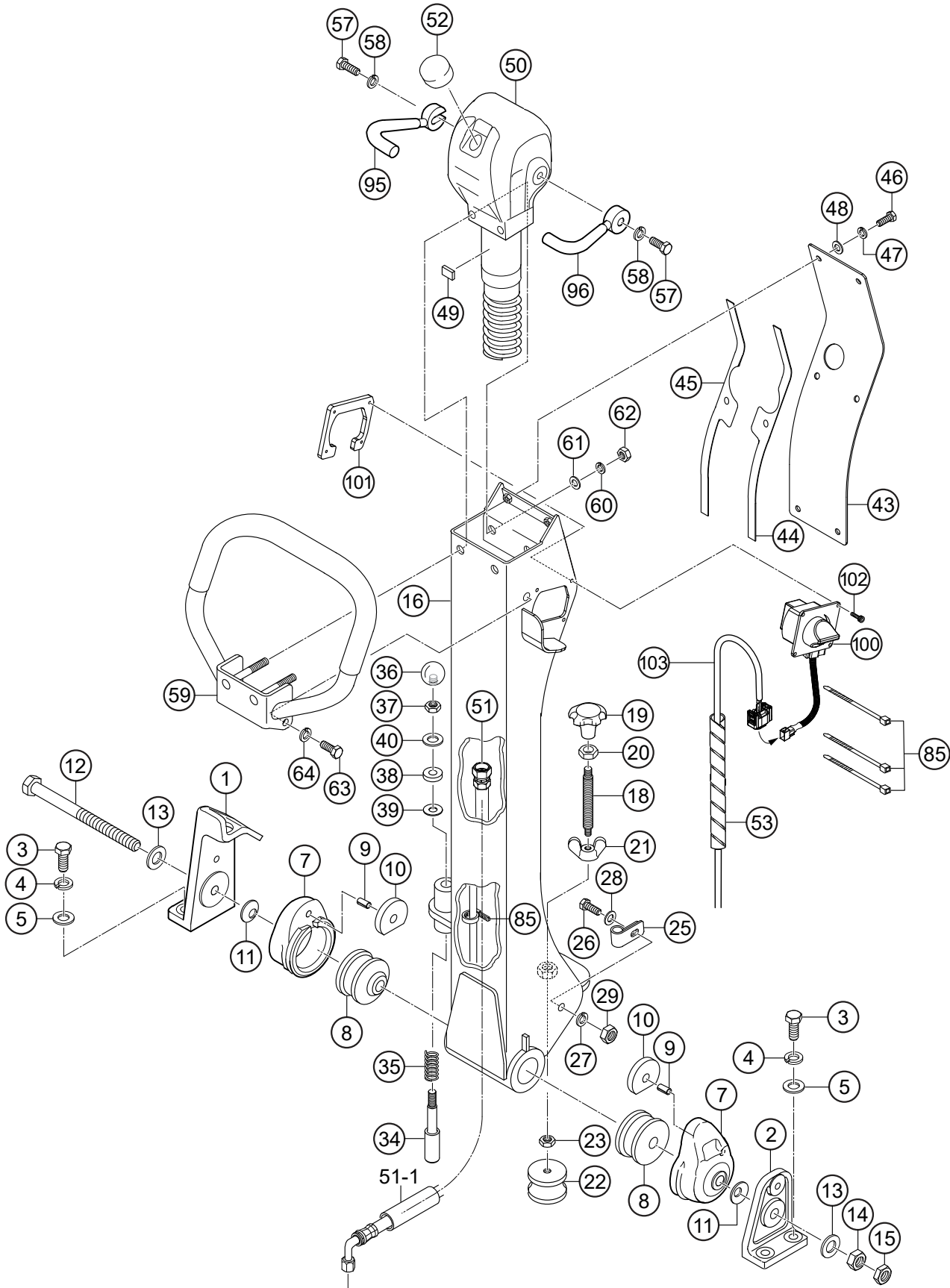

CONTROL ASSY. (CONT'D.)

<u>NO.</u>	<u>PART NO.</u>	<u>PART NAME</u>	<u>QTY.</u>	<u>REMARKS</u>
59	467218901	HANDLE W/RUBBER GRIP	1	
60	030210250	WASHER, LOCK	2	
61	031110160	WASHER, FLAT	2	
62	020310080	NUT	2	
63	0105091025	BOLT	2	REPLACES P/N 001221025
64	030210250	WASHER, LOCK	2	
85	506010070	CLAMP	4	
95	464216820	TRAVEL LEVER, RIGHT	1	
96	464216830	TRAVEL LEVER, LEFT	1	
100	50657412-508DE	CONTROL KNOB, THROTTLE	1	REPLACES P/N 026086003 INCLUDES ITEMS W/#
101	467474740	STAY, CONTROL KNOB	1	
102	001520415	SOCKET HEAD BOLT	4	
103	467358170	HARNESS, THROTTLE	1	

HYDRAULIC HAND PUMP ASSY.

TOOL FOR DISASSEMBLY
(OPTIONAL)

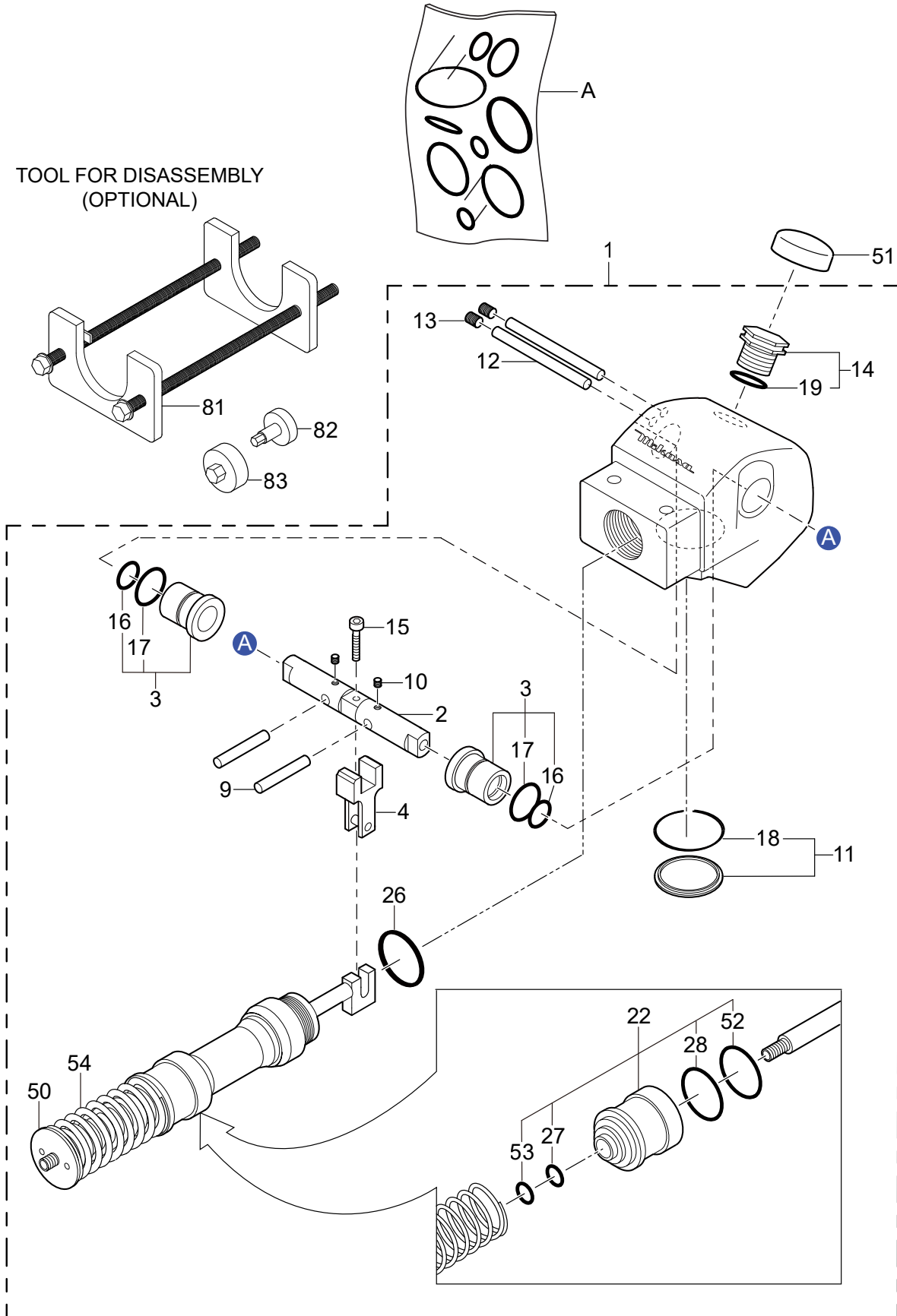

HYDRAULIC HAND PUMP ASSY.

<u>NO.</u>	<u>PART NO.</u>	<u>PART NAME</u>	<u>QTY.</u>	<u>REMARKS</u>
A	464910080	SEAL KIT	1.....	INCLUDES ITEMS W/\$
1	469219180	HAND PUMP ASSY.....	1.....	INCLUDES ITEMS W/#
2#	464010040	CONTROL SHAFT	1	
3#	467010020	BUSH	2.....	INCLUDES ITEMS W/%
4#	464010060	CAM	1	
9#	464010070	STOPPER	2	
10#	099205005	SOCKET HEAD SCREW	2	
11#	464010080	PLUG	1.....	INCLUDES ITEMS W/@
12#	464010090	PIN, STOPPER	2	
13#	464010100	PLUG	2	
14#	458010080	BREATHER.....	1.....	INCLUDES ITEMS W/*
15#	014206020	SOCKET HEAD BOLT	1.....	REPLACES P/N 001520620
16#\$\$%	050200200	O-RING, P-20	2	
17#\$\$%	050210220	O-RING, P-22	2.....	REPLACES P/N 050200220
18#\$\$@	050300380	O-RING, S-38	1	
19#\$\$*	050200180	O-RING, P-18	1	
22#	464010111	ACCUMULATOR CASE	1	
26#\$\$	050300400	O-RING, S-40	1	
27#\$\$&	050200150	O-RING, P-15	1	
28#\$\$&	050100400	O-RING, G-40	1	
50#	464010120	SPRING PLUG	1	
51	458451630	BREATHER CAP	1	
52#\$\$&	069904010	DUST SEAL, SER-40	1	
53#\$\$&	069901010	DUST SEAL, SER-15	1	
54#	468910030	ACCUMULATOR SPRING SET	1	
81	984010060	SPRING COMPRESSION TOOL	1	
82	984010040	DISASSEMBLING TOOL A	1	
83	984010050	DISASSEMBLING TOOL B	1	

ENGINE SERVICE PARTS

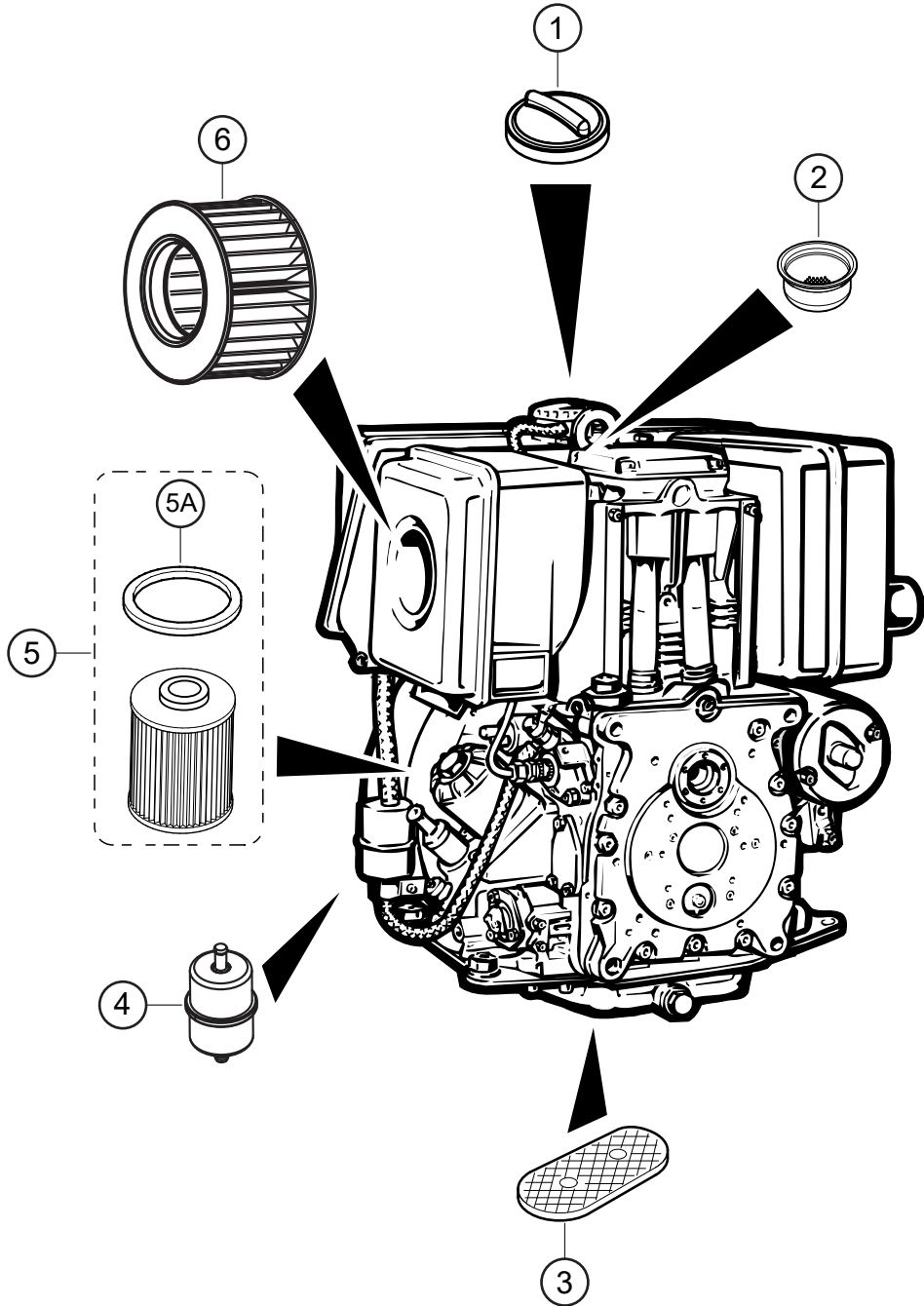

ENGINE SERVICE PARTS

<u>NO.</u>	<u>PART NO.</u>	<u>PART NAME</u>	<u>QTY.</u>	<u>REMARKS</u>
1	50385801	CAP, FUEL TANK	1	
2	50387300	FUEL FILTER/SIEVE	1	
3	03795000	OIL SUCTION SIEVE	1	
4	40089401	IN-LINE FUEL FILTER	1	
5	01480001	OIL FILTER ELEMENT	1.....	INCLUDES ITEMS W/#
5A#	50329200	RECTANGULAR RING	1	
6	01493001	ELEMENT, AIR CLEANER	1	

PARTS MANUAL

HERE'S HOW TO GET HELP

PLEASE HAVE THE MODEL AND SERIAL
NUMBER ON-HAND WHEN CALLING

UNITED STATES

Multiquip Inc.

(310) 537- 3700
6141 Katella Avenue Suite 200
Cypress, CA 90630
E-MAIL: mq@multiquip.com
WEBSITE: www.multiquip.com

CANADA

Multiquip

(450) 625-2244
4110 Industriel Boul.
Laval, Quebec, Canada H7L 6V3
E-MAIL: infocanada@multiquip.com

UNITED KINGDOM

Multiquip (UK) Limited Head Office

0161 339 2223
Unit 2, Northpoint Industrial Estate,
Globe Lane,
Dukinfield, Cheshire SK16 4UJ
E-MAIL: sales@multiquip.co.uk

© COPYRIGHT 2026, MULTIQUIP INC.

Multiquip Inc. and the MQ logo are registered trademarks of Multiquip Inc. and may not be used, reproduced, or altered without written permission. All other trademarks are the property of their respective owners and used with permission.

This manual MUST accompany the equipment at all times. This manual is considered a permanent part of the equipment and should remain with the unit if resold.

DISCLAIMER: Product features, descriptions, and specifications are based on published information at the time of publication and are subject to change at any time without notice. Multiquip Inc. and its affiliates reserve the right to change specifications, features, design, and descriptions of products at any time without notice.

