



QP205SH

MULTIQUIP® 2" High Pressure Pump

GALLONS PER MINUTE

106 (401 L)

HEAD

231 ft (70.4 M)

ENGINE

Honda GX160



APPLICATIONS

Agricultural - Construction Sites - Emergency Response - Excavation - Farms - Floods - Irrigation - Jobsite - Drainage - Mining - Municipalities - Standing Water - Swimming Pools - Quarries - Water Departments - Water Supply from Lakes/Rivers - Water Trailers/Trucks

STANDARD FEATURES

- Maximum pumping capacity of **106 gallons (401 liters) per minute.**
- Maximum lift of **25 feet (7.6 meters).**
- Aluminum body and fittings.
- High-Efficiency impeller and volute for maximum fluid transfer.
- Closed sand-cast aluminum impeller and die cast aluminum volute for **extreme high-pressure performance.**
- Ceramic carbide mechanical seal provides **extreme abrasion resistance** and **high temperature operation.**
- **3-way discharge ports** can be used independently or simultaneously depending on the application.
- 1" (25.4 mm) diameter fill and drain ports.
- Engine oil-alert to protect the engine in the case of low engine oil.
- Trusted 4.8HP **Honda GX160** gasoline engine.
- Heavy-duty **7/8" (20.2 mm) tubular steel frame** for transportation and pump protection.

WARRANTY*

QP205SH: 24 months from date of purchase.

Honda GX160 Engine: 36 months from date of purchase.

Hoses: 3 months from date of purchase.

*Refer to the MULTIQUIP NEW PRODUCT LIMITED WARRANTY FOR FULL TERMS AND CONDITIONS.

FEATURES

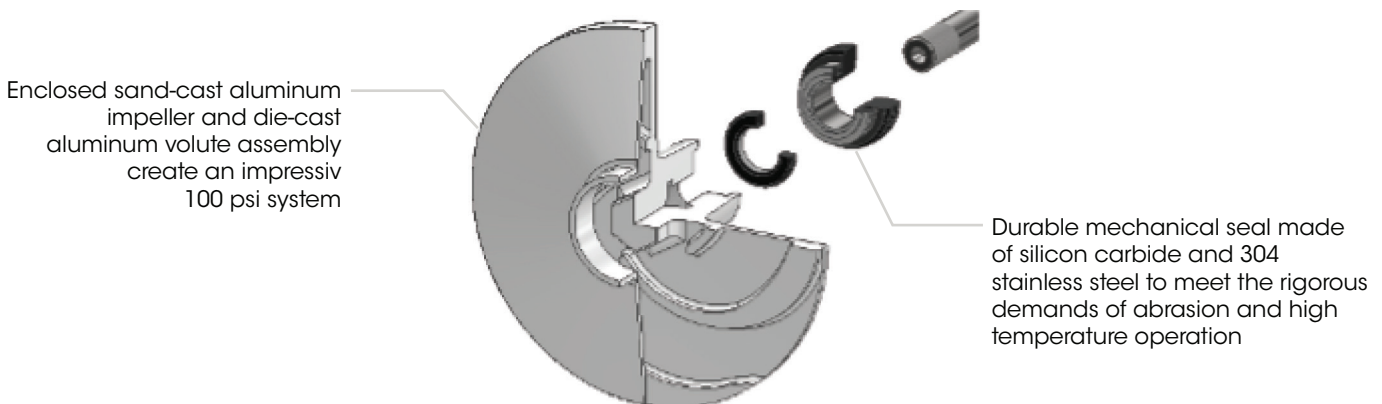
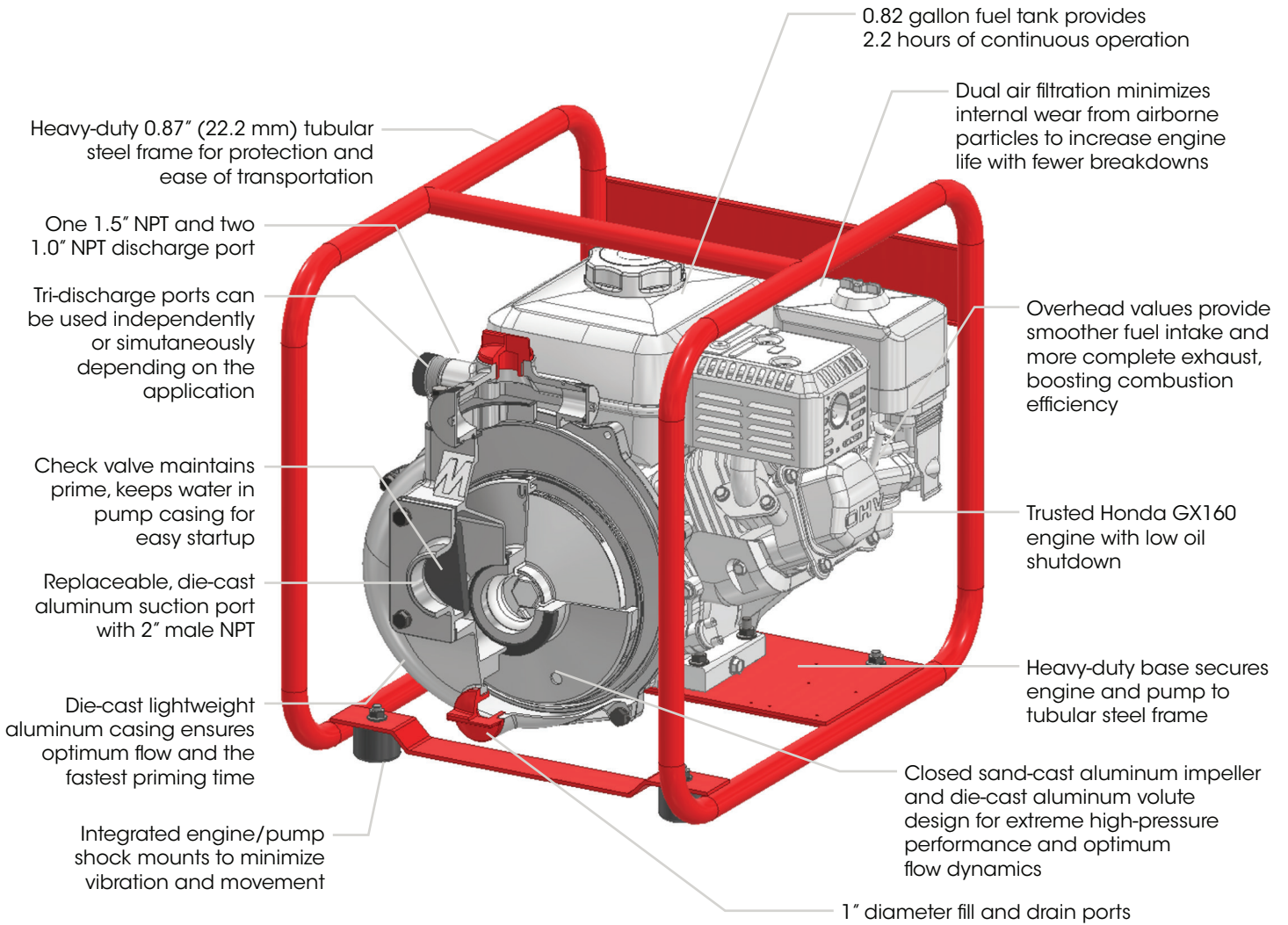

PUMP CURVE

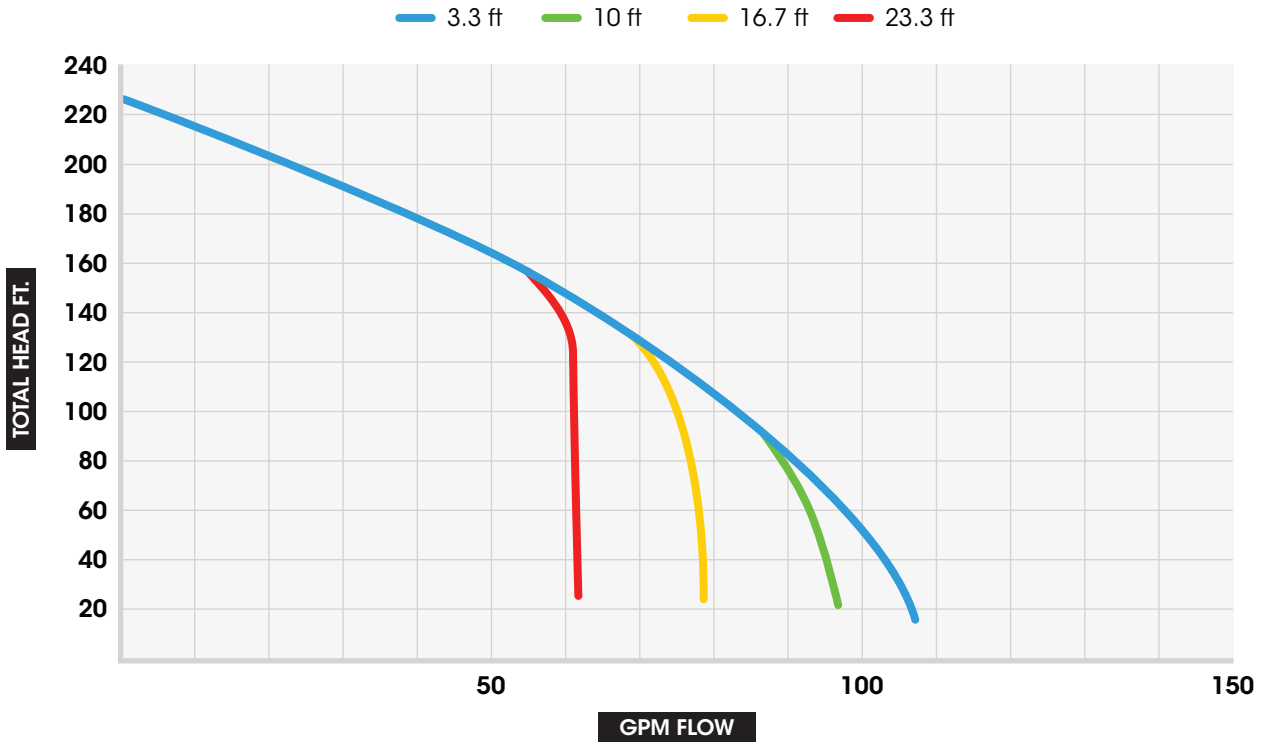

PUMP DIMENSIONS

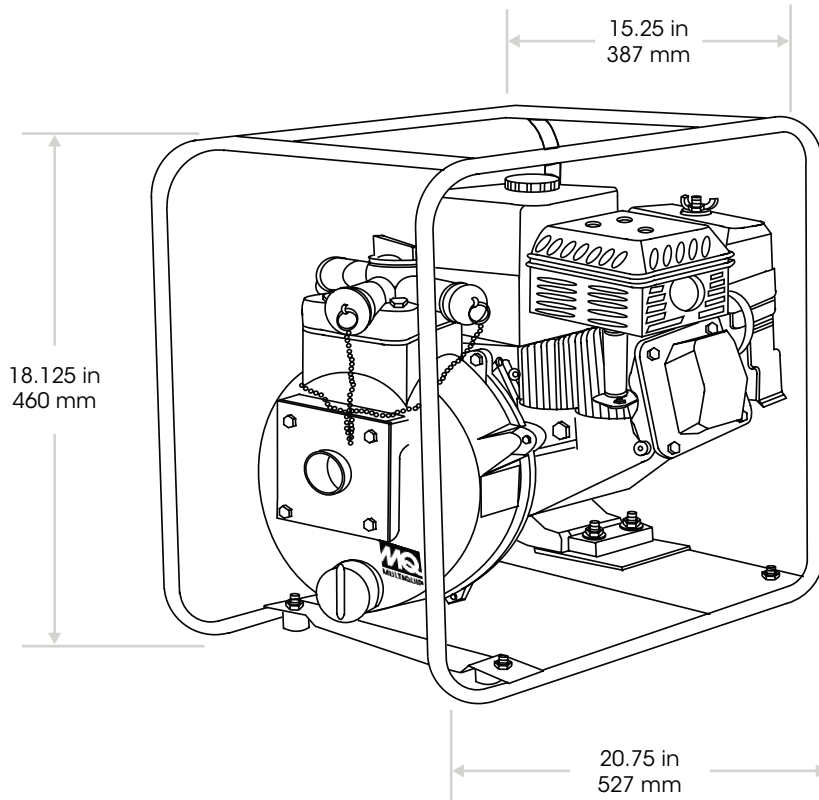

SPECIFICATIONS

PUMP SPECIFICATIONS	
MODEL	QP205SH
TYPE	CENTRIFUGAL HIGH-PRESSURE PUMP
IMPELLER TYPE	CLOSED
MAX. PUMP CAPACITY	106 GALLONS/MINUTE (401 L/MIN)
MAX. SUCTION	25 FT (7.62 M)
MAX. HEAD	231 FT (70.4 M)
SUCTION PORT SIZE	2 IN (50.8 MM)
DISCHARGE PORT SIZE	1 X 1.50 in. (38.1 mm) 2 X 1.00 in. (25.4 mm)
THREAD TYPE	NPT (MALE)
PSI	100
IMPELLER MATERIAL	SAND-CAST ALUMINUM
VOLUTE MATERIAL	DIE-CAST ALUMINUM
PUMP CASING MATERIAL	DIE-CAST ALUMINUM
CHECK VALVE MATERIAL	NITRILE BUTADIENE RUBBER
MECHANICAL SEAL MATERIAL	CERAMIC/CARBON 304 STAINLESS STEEL
DRAIN AND FILL CAP MATERIAL	ACRYLONITRILE BUTADIENE STYRENE
SALT OR CHEMICALS	NO
PUMP HARDWARE	STEEL
MAX. FLUID TEMPERATURE	104° F (40° C)
MAX. SOLID HANDLING	0.18 IN (4.5 MM)
O-RINGS	NITRILE BUTADIENE RUBBER
STRAINER SIZE	2 IN (50.8 MM) NPT
STRAINER INLET SIZE	0.3125 IN (8 MM) INCLUDES NYLON SET

ENGINE SPECIFICATIONS	
MAKE/MODEL	HONDA/GX160
EMISSIONS	EPA CERTIFIED AND CARB PREEMPT
STARTING METHOD	RECOIL START
DESIGN	AIR-COOLED, 4 STROKE, SINGLE CYLINDER, OHV, HORIZONTAL SHAFT
DISPLACEMENT	163 CC (9.9 CU-IN)
BORE X STROKE	2.7 IN X 1.8 IN (68 MM X 45 MM)
HORSE POWER (kW)	4.8 (3.6)
ENGINE SPEED	3,600 RPM
GOVERNOR SPEED	MECHANICAL
SOUND LEVEL dB(A) AT 23 FT	74
AIR CLEANER	DUAL ELEMENT
LUBRICATION SYSTEM	SPLASH
SPARK ARRESTOR	OPTIONAL
OIL CAPACITY	0.61 QUARTS (0.58 LITERS)
OIL TYPE	SAE 10W-30
LOW OIL SHUT-DOWN	STANDARD

FUEL SPECIFICATIONS	
RECOMMENDED FUEL	UNLEADED GASOLINE
FUEL TANK CAPACITY	0.82 GALLONS (3.1 L)
FUEL CONSUMPTION	0.37 GPH (1.4 LPH)
RUN TIME	2.2 HOURS

WEIGHT AND DIMENSIONS	
DRY WEIGHT	64 LB (29 KG)
DIMENSIONS	20.75 x 15.25 x 18.125 IN (527 x 387 x 460 MM)

NOTICE Features and Specifications are subject to change without notice.

OPTIONS

SUCTION HOSES

- **HS220C** – 2" x 20 ft., 65psi, rigid PVC helix reinforced, NPS thread
- **HSQ220C** – 2" x 20 ft., 65psi, rigid PVC helix reinforced, NPT thread, Male Camlock, includes one quick disconnect coupler
- **HS225C** – 2" x 25 ft., 65psi, rigid PVC helix reinforced, NPS thread
- **HSQ225C** – 2" x 25 ft., 65psi, rigid PVC helix reinforced, NPT thread, Male Camlock, includes one quick disconnect coupler
- **A200A** – 2" type A coupler, male quick disconnect x female NPT



HS220C and HS225C

HSQ220C and HSQ225C

DISCHARGE HOSES

- **FIRENOZ15** – 1.5" nozzle, NPT thread
- **HDFNST** – 2.5" x 25 ft., 150psi, NPT thread, includes one quick disconnect coupler
- **A150A** – 1.5" type A coupler, male quick disconnect x female NPT



FIRENOZ15

HDFNST

A150A

FILTER KIT

- **MKITPUMP-2** – (1) Air cleaner element, (1) spark plug, (5) flooding caps



WHEEL KIT

- **UWKB** – Wheel kit with folding handles and flat free tires for easy transport

SINGLE DISCHARGE PORT

- **KIT205SD** – (1) 2" Port with Male NPT, and mounting hardware