

PARTS MANUAL



MODEL QP3THX TRASH PUMP (HONDA GX240RT2QMTNH1 GASOLINE ENGINE)

Revision #2 (06/03/20)

To find the latest revision of this publication or associated operation manual, visit our website at: www.multiquip.com



THIS MANUAL MUST ACCOMPANY THE EQUIPMENT AT ALL TIMES.

QP3THX Trash Pump

Explanation Of Code In Remarks Column..... 4
Suggested Spare Parts 5

Component Drawings

Nameplate And Decals Assembly 6-7
Pump Assembly 8-11
Frame Assembly 12-13
Fuel Tank Assembly 14-15
Engine Service Parts 16-17

NOTICE

Specifications and part numbers are subject to change without notice.

EXPLANATION OF CODE IN REMARKS COLUMN

The following section explains the different symbols and remarks used in the Parts section of this manual. Use the help numbers found on the back page of the manual if there are any questions.

NOTICE

The contents and part numbers listed in the parts section are subject to change **without notice**. Multiquip does not guarantee the availability of the parts listed.

SAMPLE PARTS LIST

NO.	PART NO.	PART NAME	QTY.	REMARKS
1	12345	BOLT	1	INCLUDES ITEMS W/%
2%		WASHER, 1/4 IN.		NOT SOLD SEPARATELY
2%	12347	WASHER, 3/8 IN. ...	1	MQ-45T ONLY
3	12348	HOSE	A/R	MAKE LOCALLY
4	12349	BEARING	1	S/N 2345B AND ABOVE

NO. Column

Unique Symbols — All items with same unique symbol (@, #, +, %, or >) in the number column belong to the same assembly or kit, which is indicated by a note in the “Remarks” column.

Duplicate Item Numbers — Duplicate numbers indicate multiple part numbers, which are in effect for the same general item, such as different size saw blade guards in use or a part that has been updated on newer versions of the same machine.

NOTICE

When ordering a part that has more than one item number listed, check the remarks column for help in determining the proper part to order.

PART NO. Column

Numbers Used — Part numbers can be indicated by a number, a blank entry, or TBD.

TBD (To Be Determined) is generally used to show a part that has not been assigned a formal part number at the time of publication.

A blank entry generally indicates that the item is not sold separately or is not sold by Multiquip. Other entries will be clarified in the “Remarks” Column.

QTY. Column

Numbers Used — Item quantity can be indicated by a number, a blank entry, or A/R.

A/R (As Required) is generally used for hoses or other parts that are sold in bulk and cut to length.

A blank entry generally indicates that the item is not sold separately. Other entries will be clarified in the “Remarks” Column.

REMARKS Column

Some of the most common notes found in the “Remarks” Column are listed below. Other additional notes needed to describe the item can also be shown.

Assembly/Kit — All items on the parts list with the same unique symbol will be included when this item is purchased.

Indicated by:

“INCLUDES ITEMS W/(unique symbol)”

Serial Number Break — Used to list an effective serial number range where a particular part is used.

Indicated by:

“S/N XXXXX AND BELOW”

“S/N XXXX AND ABOVE”

“S/N XXXX TO S/N XXX”

Specific Model Number Use — Indicates that the part is used only with the specific model number or model number variant listed. It can also be used to show a part is NOT used on a specific model or model number variant.

Indicated by:

“XXXXX ONLY”

“NOT USED ON XXXX”

“Make/Obtain Locally” — Indicates that the part can be purchased at any hardware shop or made out of available items. Examples include battery cables, shims, and certain washers and nuts.

“Not Sold Separately” — Indicates that an item cannot be purchased as a separate item and is either part of an assembly/kit that can be purchased, or is not available for sale through Multiquip.

SUGGESTED SPARE PARTS

QP3THX TRASH PUMP

1 to 3 units

Qty.	P/N	Description
1	1992040033	IMPELLER
1	0811885446	MECH. SEAL SLEEVE
2	0803442930	MECHANICAL SEAL
2	0631211159	CAP, FLD. WITH O-RING
2	0483602250	O-RING (DRAIN COVER)
2	0489403400	O-RING (CASING)
2	0482200240	O-RING (IMP.MECH.SEAL)
4	0852834525	ADJUST LINER .30
4	0852854525	ADJUST LINER .50
1	8910240950	FUEL CAP
1	8910310980	FUEL FILTER

NOTICE

Part numbers on this Suggested Spare Parts list may supersede/replace the part numbers shown in the following parts lists.

HONDA GX240RT2QMTNH1 ENGINE

1 to 3 units

Qty.	P/N	Description
2	172118990000	ELEMENT,AIRCLEANER
3	9807956846	SPARK PLUG (BPR6ES)
1	28462ZE2W11	ROPE, RECOIL START
1	28461Z5T003	KNOB, RECOIL START

NAMEPLATE AND DECALS ASSY.

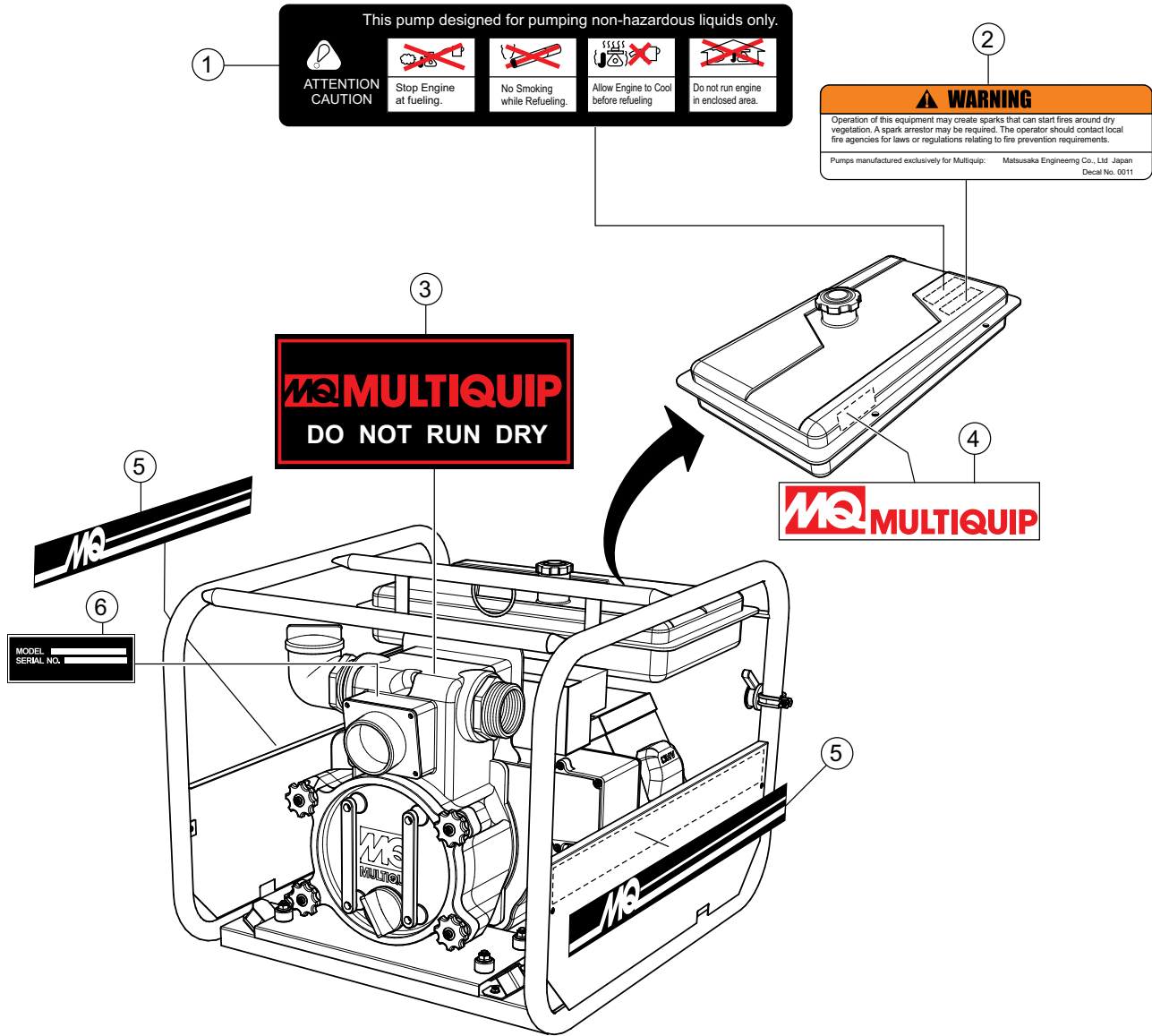

NAMEPLATE AND DECALS ASSY.

<u>NO.</u>	<u>PART NO.</u>	<u>PART NAME</u>	<u>QTY.</u>	<u>REMARKS</u>
1	2200121	DECAL: CAUTION, HAZARDOUS LIQUIDS	1	
2	2200231	DECAL: WARNING, START FIRES	1	
3	2200201	DECAL: DO NOT RUN DRY	1	
4	2200191	DECAL: MQ LOGO, FUEL TANK	1	
5	2200131	DECAL: MQ LOGO, FRAME	2	
6		SERIAL PLATE	1.....	CONTACT MQ PARTS DEPT.

PUMP ASSEMBLY

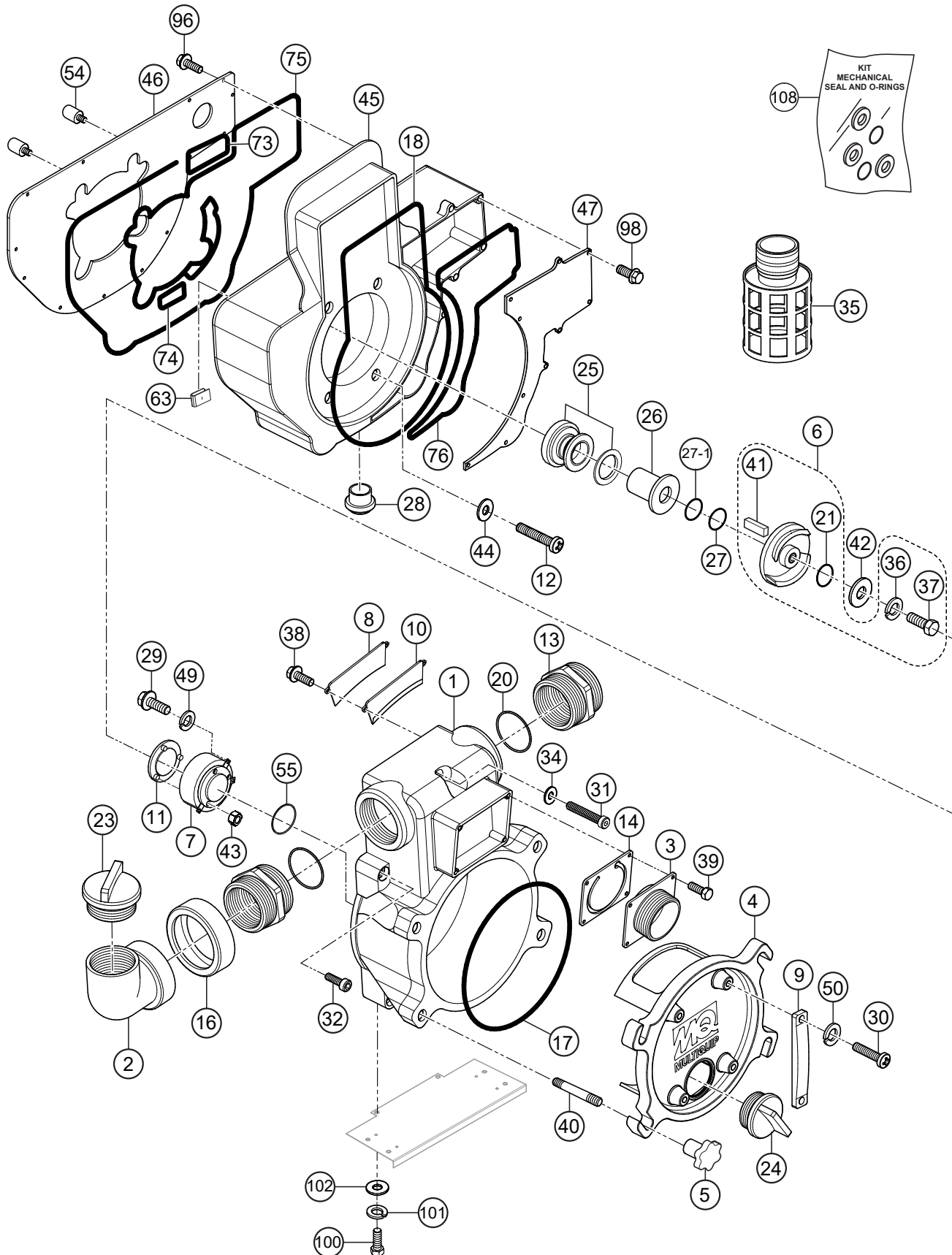

PUMP ASSEMBLY

<u>NO.</u>	<u>PART NO.</u>	<u>PART NAME</u>	<u>QTY.</u>	<u>REMARKS</u>
1	1992100011	CASING	1	
2	89100015500014	FLOODING ELBOW	1	
3	13910001600014	SUCTION COVER	1	
4	1992100173	DRAIN COVER	1	
5	19920002200014	DRAIN COVER HANDLE	4	
6	1992040033ASSY	IMPELLER	1	REPLACES P/N 1992040033 INCLUDES ITEMS W/%
7	1992000110	VOLUTE CASING	1	
8	1992100742	SUCTION PLATE	1	
9	12471002500002	DRAIN COVER SET HANDLE.....	2	REPLACES P/N 1247100250
10	1992330410	SUCTION PLATE PACKING	1	
11	1992250700	WEAR PLATE	1	
12	0131290689	CAP SCREW (CASING COVER SET BOLT)	4	
13	07904330300014	NIPPLE	2	
14	1378350350	CHECK VALVE	1	
16	8910131560	FLOODING ELBOW COUPLING	1	
17#	0483602250	O-RING (DRAIN COVER)	1	
18	0489403400	O-RING (CASING)	1	
20	0481310800	O-RING (NIPPLE)	2	
21%#	0482200240	O-RING (IMPELLER, MECHANICAL SEAL)	2	
23	0631211159	FLOODING CAP W/O-RING	1	
24	0631211159	FLOODING CAP W/O-RING	1	
25#	0803442930	MECHANICAL SEAL	1	
26#	0811885446	MECHANICAL SEAL SLEEVE	1	
27#	0852834525	ADJUST LINER	1	
27-1#	0852854525	ADJUST LINER	1	
28	0631214057	PLUG	1	
29	0131190823	CAP SCREW (VOLUTE CASING)	4	
30	0141090825	SCREW (DRAIN COVER SET HANDLE)	4	
31	0131191290	CAP SCREW (CASING)	1	
32	0131191235	CAP SCREW (CASING)	4	
34	0459220120	SEAL WASHER (CASING COVER)	1	
35	0742214080	STRAINER	1	
36%	0458220100	SEAL WASHER IMPELLER	1	
37%	0191190750	BOLT IMPELLER	1	

PUMP ASSEMBLY (CON'T.)

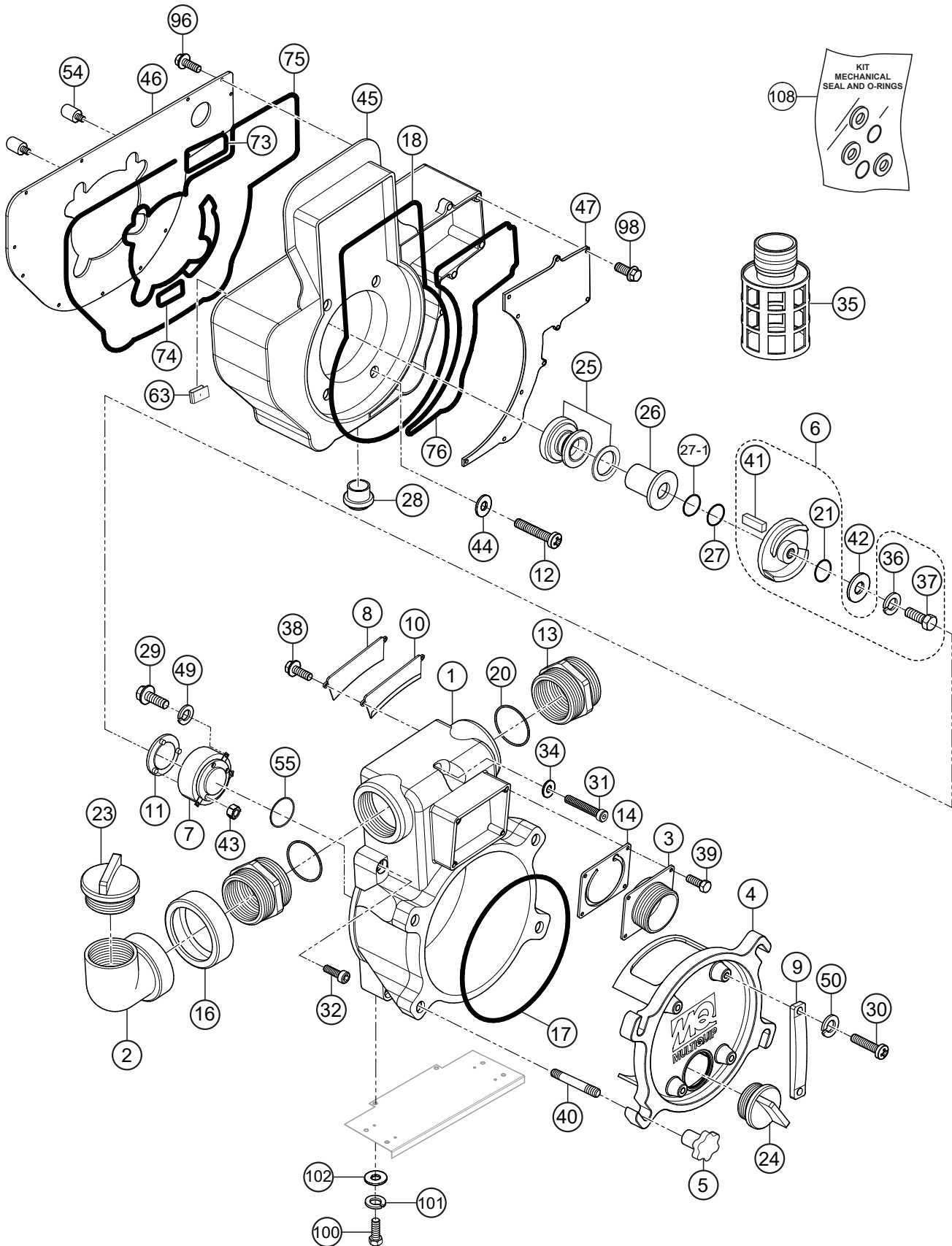

PUMP ASSEMBLY (CON'T.)

<u>NO.</u>	<u>PART NO.</u>	<u>PART NAME</u>	<u>QTY.</u>	<u>REMARKS</u>
38	0181090820	BOLT W/LOCK WASHER (SUCTION PLATE)	2	
39	0181090825	BOLT W/LOCK WASHER (SUCTION COVER)	4	
40	0151191257	STUD BOLT (DRAIN COVER HANDLE)	4	
41%	0520040431	KEY, IMPELLER	1	
42	1466251240	IMPELLER WASHER.....	1.....	REPLACES P/N 43342012400011
43	0204490060	U-NUT WEAR PLATE	3	
44	0458220071	SEAL, WASHER (CASING COVER)	4	
45	8910100520	CASING COVER	1	
46	8910101440	CASING COVER PLATE (ENGINE SIDE)	1	
47	8910101450	CASING COVER PLATE (CASING SIDE)	1	
49	0451290080	LOCK, WASHER (VOLUTE CASING)	4	
50	0451290080	LOCK, WASHER (DRAIN CVR. SET HANDLE)	4	
54	8910503760	SILENCER	2	
55	0480570850	O-RING (VOLUTE CASING)	1	
63	0472512020	CLIP	3	
73	8910670460	SILICON O-RING 1	1	
74	8910670470	SILICON O-RING 2	1	
75	8910670480	SILICON O-RING 3	1	
76	8910670490	SILICON O-RING 4	1	
96	0105060616	HEX. HEAD SCREW W/CAPTIVE WASHER	23	
98	0161050510	FLAT HEAD SCREW	10	
100	012210020	BOLT.....	2.....	REPLACES P/N 0105051020
101	0451250100	LOCK, WASHER	2	
102	031110160	FLAT, WASHER.....	2.....	REPLACES P/N 0401450100
108	KIT3TE	MECH. SEAL, SLEEVE, AND O-RINGS.....	1.....	INCLUDES ITEMS W/#

FRAME ASSY.

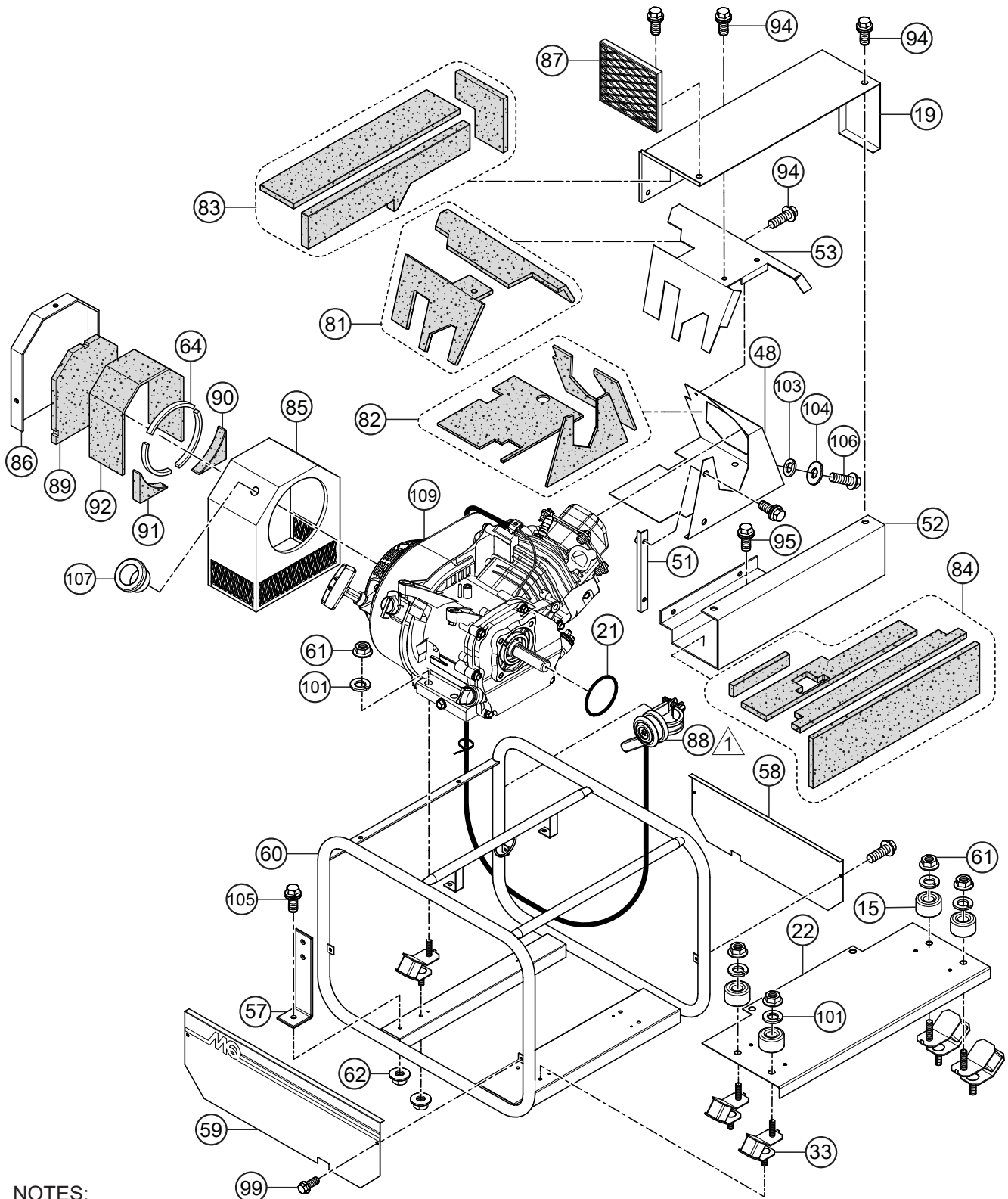

NOTES:

▲ THROTTLE LEVER
INCLUDES CABLE.

FRAME ASSY.

<u>NO.</u>	<u>PART NO.</u>	<u>PART NAME</u>	<u>QTY.</u>	<u>REMARKS</u>
15	73082246500014	CUSHION RUBBER SPACER	4	
19	8910205130C014	DUCT H	1	
21%#	0482200240	O-RING (IMPELLER, MECHANICAL SEAL)	2	
22	8910214550C014	CUSHION RUBBER PLATE	1	
33	0725223229	CUSHION RUBBER	6	
48	8910215110C014	DUCT G	1	
51	8910215120C014	ACCESSORY (DUCT G)	1	
52	8910215140C014	DUCT I	1	
53	8910215180C014	DUCT F	1	
57	8911204320P002	BRACKET (CANISTER)	1	
58	8911204680C014	SIDE PANEL (RIGHT HAND)	1	
59	8911204690C014	SIDE PANEL (LEFT HAND)	1	
60	8911214010P002	BASE	1	
61	0205490101	NUT	6	
62	0209150080	FLANGE NUT	7	
64	0490230500	URETHANE SHEET	1	
81	8910718350	GLASS WOOL (DUCT F)	1	
82	8910718360	GLASS WOOL (DUCT G)	1	
83	8910718370	GLASS WOOL (DUCT H)	1	
84	8910718380	GLASS WOOL (DUCT I)	1	
85	8911214560C014	BOX (RECOIL)	1	
86	8911214570C014	COVER (RECOIL)	1	
87	8911215190C014	DUCT END COVER	1	
88	8911237080	THROTTLE LEVER W/CABLE	1	
89	8911718310	GLASS WOOL (RECOIL COVER)	1	
90	8911718320	GLASS WOOL (BOX RECOIL)	1	
91	8911718330	GLASS WOOL (BOX RECOIL)	1	
92	8911718340	GLASS WOOL (BOX RECOIL)	1	
94	0105060510	HEX. HEAD SCREW W/CAPTIVE WASHER	12	
95	0105060612	HEX. HEAD SCREW W/CAPTIVE WASHER	2	
99	0141150616	SCREW	4	
101	0451250100	LOCK, WASHER	6	
103	0401450080	FLAT, WASHER	1	
104	0451290080	LOCK, WASHER	1	REPLACES P/N 0451250080
105	0105060820	HEX. HEAD SCREW W/CAPTIVE WASHER	1	
106	0105050816	BOLT	1	
107	C600000004	ROPE BUSHING	1	
109	GX240RT2QMTNH1	ENGINE, HONDA	1	

FUEL TANK ASSY.

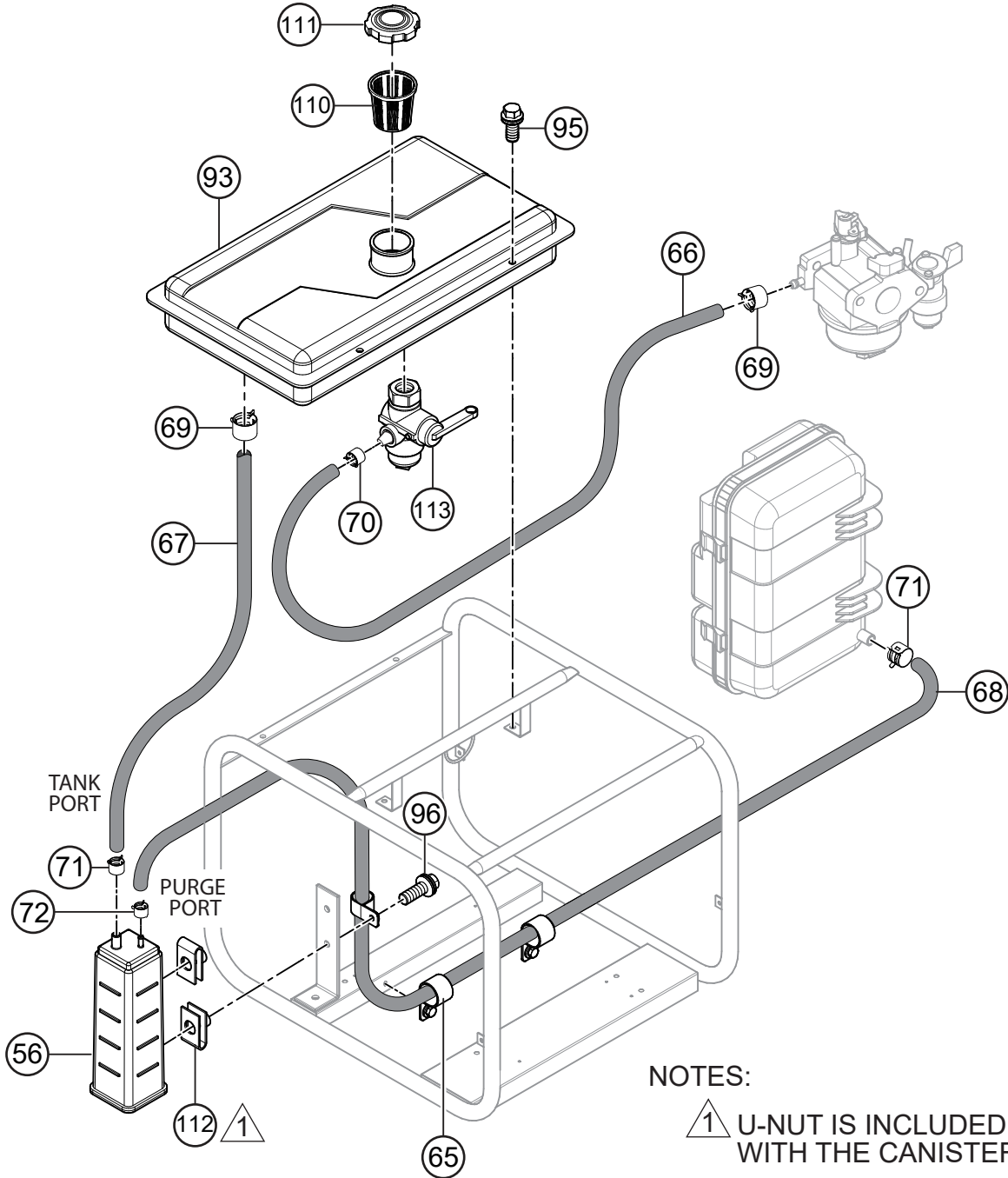

FUEL TANK ASSY.

<u>NO.</u>	<u>PART NO.</u>	<u>PART NAME</u>	<u>QTY.</u>	<u>REMARKS</u>
56	8910802500	CANISTER.....	1.....	INCLUDES ITEM W/@
66	8911343700	HOSE (COCK-CARBURETOR)	1	
67	8910343720	HOSE (FUEL TANK-CANISTER)	1	
68	8910343730	HOSE (AIR CLEANER-CANISTER)	1	
69	0937200008	HOSE CLIP	2	
70	0937200009	HOSE CLIP	1	
71	0937200012	HOSE CLIP	2	
72	0937200014	HOSE CLIP	1	
95	0105060612	HEX. HEAD SCREW W/CAPTIVE WASHER	4	
110	8910310980	FUEL FILTER	1	
111	8910240950	FUEL CAP	1	
112@		U-NUT, CANISTER.....	2.....	NOT SOLD SEPARATELY
113	8910140990	FUEL VALVE	1	

ENGINE SERVICE PARTS

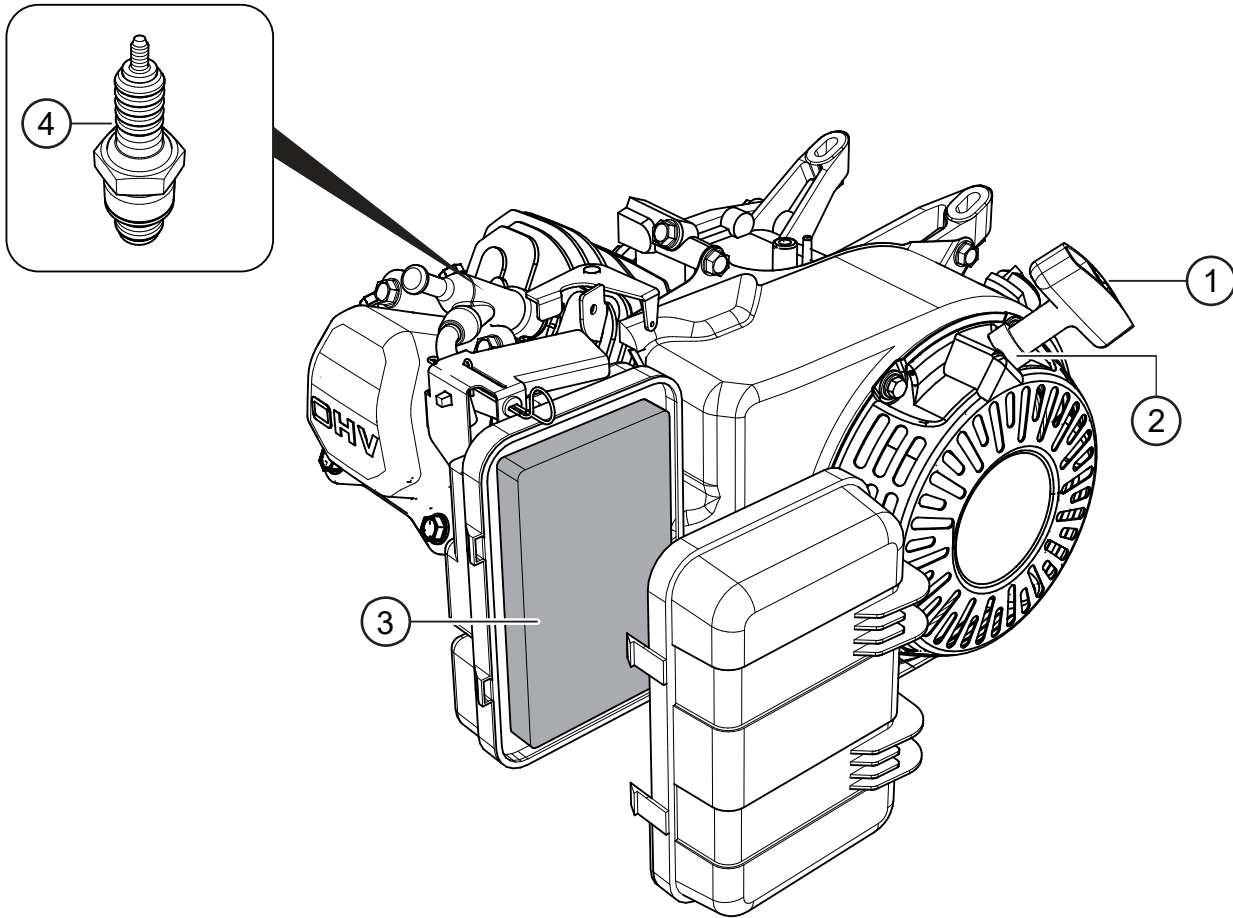

ENGINE SERVICE PARTS

<u>NO.</u>	<u>PART NO.</u>	<u>PART NAME</u>	<u>QTY.</u>	<u>REMARKS</u>
1	28461Z5T003	KNOB, RECOIL START	1	
2	28462ZE2W11	ROPE, RECOIL START	1	
3	172118990000	ELEMENT, AIR CLEANER	1	
4	9807956846	SPARK PLUG (BPR6ES)	1	

PARTS MANUAL

HERE'S HOW TO GET HELP

PLEASE HAVE THE MODEL AND SERIAL
NUMBER ON-HAND WHEN CALLING

UNITED STATES

Multiquip Inc.

(310) 537- 3700
6141 Katella Avenue Suite 200
Cypress, CA 90630
E-MAIL: mq@multiquip.com
WEBSITE: www.multiquip.com

CANADA

Multiquip

(450) 625-2244
4110 Industriel Boul.
Laval, Quebec, Canada H7L 6V3
E-MAIL: infocanada@multiquip.com

UNITED KINGDOM

Multiquip (UK) Limited Head Office

0161 339 2223
Unit 2, Northpoint Industrial Estate,
Globe Lane,
Dukinfield, Cheshire SK16 4UJ
E-MAIL: sales@multiquip.co.uk

© COPYRIGHT 2020, MULTIQUIP INC.

Multiquip Inc, the MQ logo are registered trademarks of Multiquip Inc. and may not be used, reproduced, or altered without written permission. All other trademarks are the property of their respective owners and used with permission.

This manual MUST accompany the equipment at all times. This manual is considered a permanent part of the equipment and should remain with the unit if resold.

The information and specifications included in this publication were in effect at the time of approval for printing. Illustrations, descriptions, references and technical data contained in this manual are for guidance only and may not be considered as binding. Multiquip Inc. reserves the right to discontinue or change specifications, design or the information published in this publication at any time without notice and without incurring any obligations.

Your Local Dealer is:

