

MQ QP4TH

MULTIQUIP® 4" Trash Pump

GALLONS PER MINUTE

555 (2100 L)

HEAD

92 ft (28 M)

ENGINE

Honda GX340



APPLICATIONS

Agricultural - Construction Sites - Dirty Water - Emergency Response - Excavation - Farms, Floods - Irrigation, Jobsite Drainage - Mining, Municipalities - Standing Water - Swimming Pools - Quarries - Water Departments - Water Supply from Lakes/Rivers

STANDARD FEATURES

- Maximum pumping capacity of **555 gallons (2100 liters) per minute.**
- Maximum lift of **25 feet (7.6 meters).**
- Sand-cast aluminum body with cast-iron fittings.
- Large cleanout cover removes in seconds.
- Pumps water with solid content as large as **2" (50.8 mm) in diameter.**
- High-Efficiency impeller and volute for maximum fluid transfer.
- Ductile iron impeller and volute for abrasion resistance/long life.
- Durable silicon carbide mechanical seal provides extreme abrasion resistance and high temperature operation.
- **Dual 4-inch discharge ports** for easy hose orientation and flexibility.
- 1.5" (38.1 mm) diameter fill and drain ports.
- Trusted 10.7HP **Honda GX340** gasoline engine.
- Engine oil-alert to protect the engine in the case of low engine oil.
- Heavy-duty **1.07" (27.2 mm) tubular steel frame** for transportation and pump protection.

WARRANTY*

QP4TH: 24 months from date of purchase.

Honda GX340 Engine: 36 months from date of purchase.

Hoses: 3 months from date of purchase.

*Refer to the MULTIQUIP NEW PRODUCT LIMITED WARRANTY FOR FULL TERMS AND CONDITIONS.

FEATURES

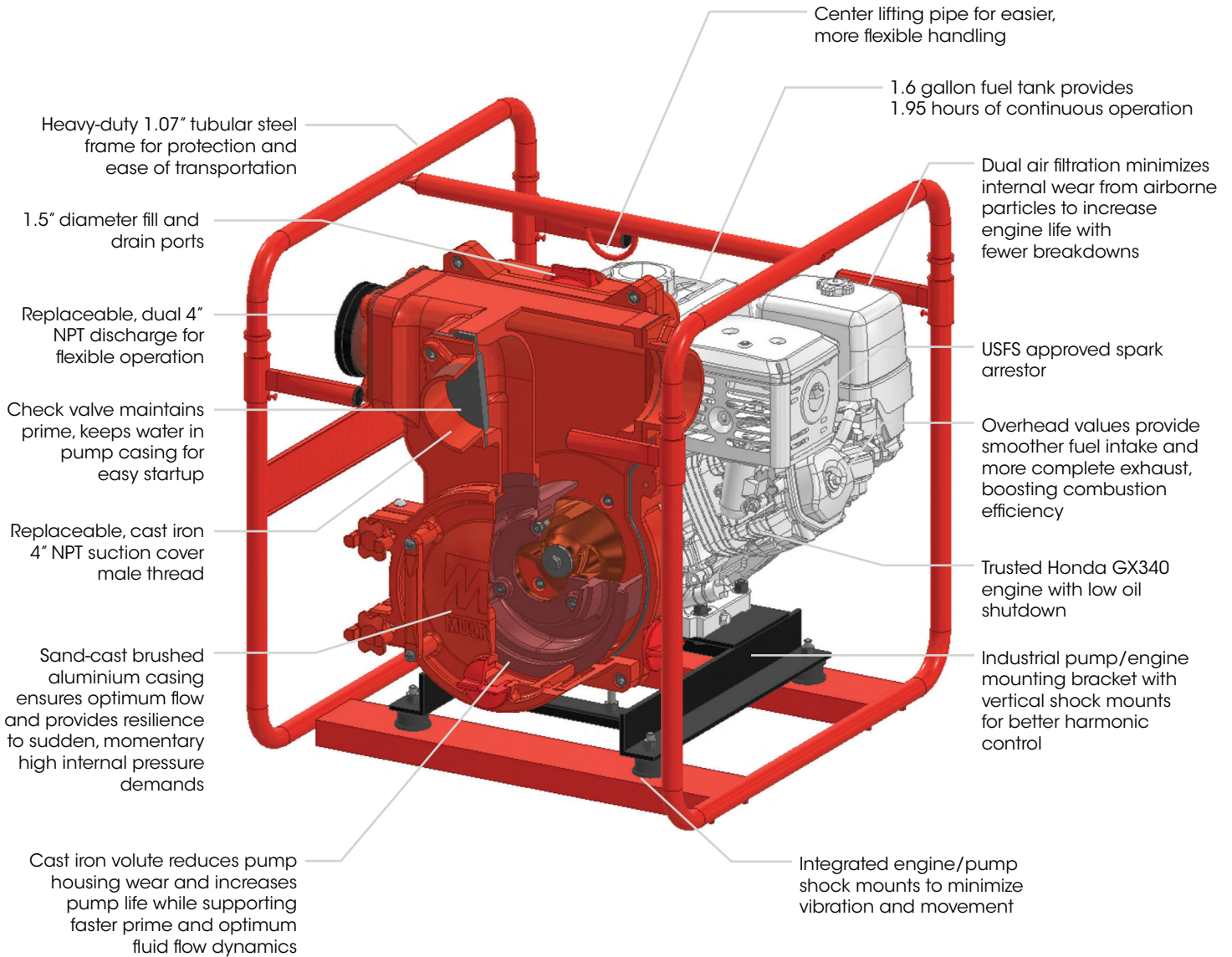

© COPYRIGHT 2026 MULTIQUIP INC. (REV 03172026)

PUMP CURVE

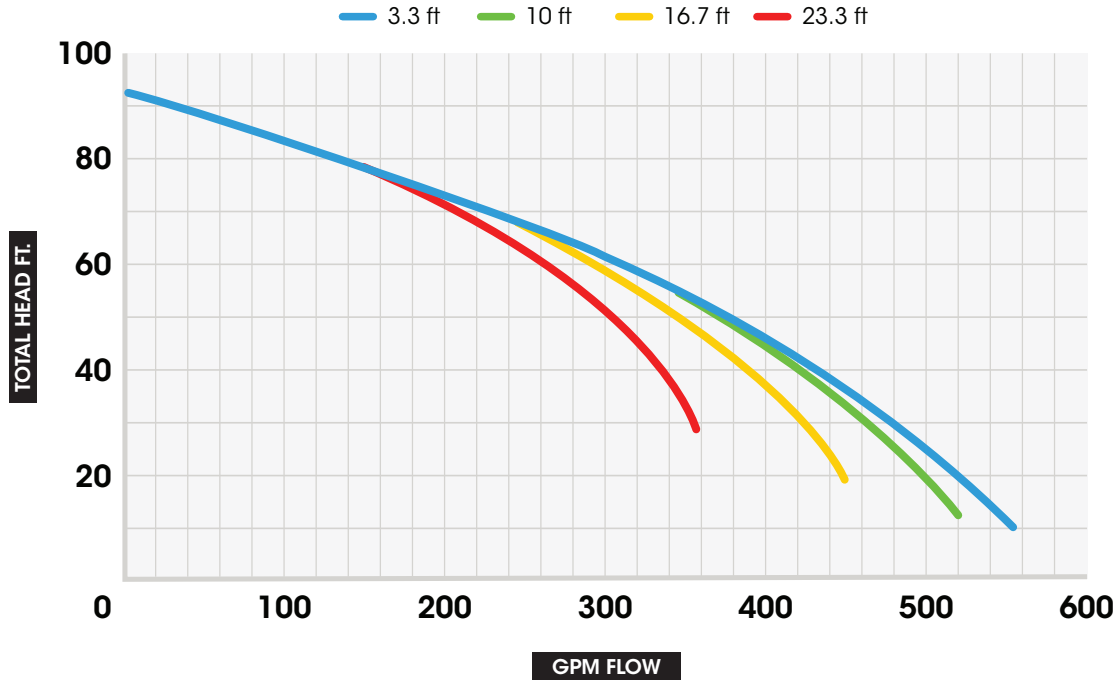

PUMP DIMENSIONS

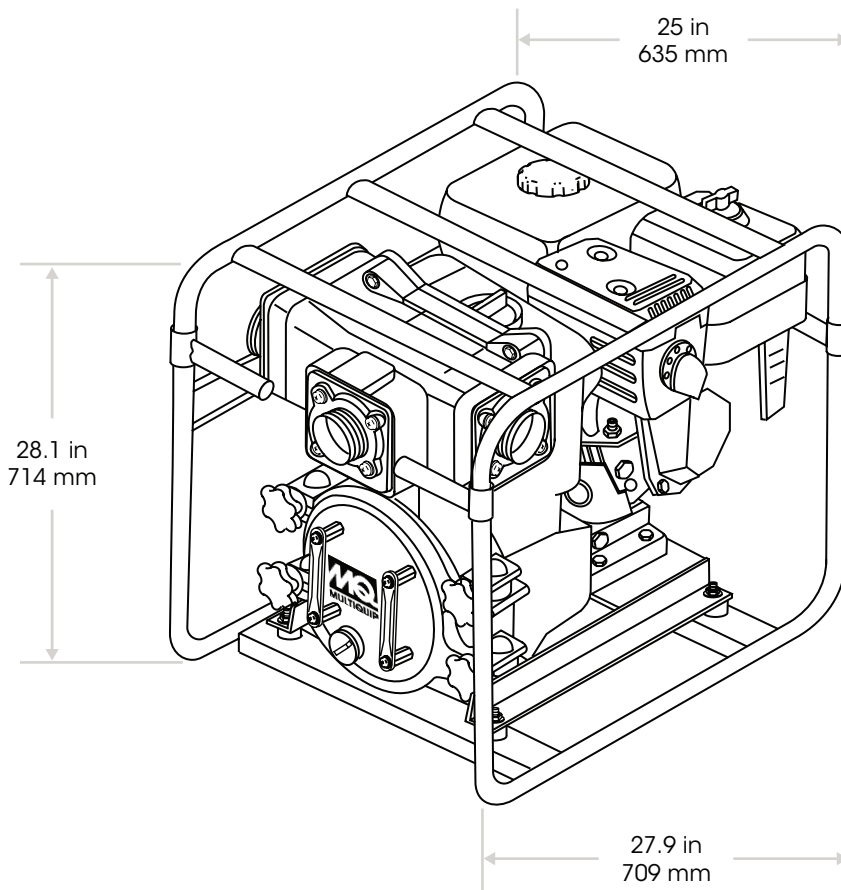

SPECIFICATIONS

PUMP SPECIFICATIONS	
MODEL	QP4TH
TYPE	TRASH PUMP
IMPELLER TYPE	SEMI-OPEN
MAX. PUMP CAPACITY	555 GALLONS/MINUTE (2100 L/MIN)
MAX. SUCTION	25 FT (7.62 M)
MAX. HEAD	92 FT (28 M)
SUCTION/DISCHARGE PORT SIZE	4 IN (100 MM)
THREAD TYPE	NPT (MALE)
PSI	40.0
IMPELLER MATERIAL	DUCTILE IRON
VOLUTE MATERIAL	CAST IRON
PUMP CASING MATERIAL	SAND-CAST ALUMINUM
CHECK VALVE MATERIAL	NITRILE BUTADIENE RUBBER
MECHANICAL SEAL MATERIAL	SILICON CARBIDE/304 STAINLESS STEEL
DRAIN AND FILL CAP MATERIAL	ACRYLONITRILE BUTADIENE STYRENE
SALT OR CHEMICALS	NO
PUMP HARDWARE	STEEL
MAX. FLUID TEMPERATURE	104° F (40° C)
MAX. SOLID HANDLING	2 IN (50.8 MM)
O-RINGS	NITRILE BUTADIENE RUBBER
STRAINER SIZE	4 IN (100 MM) NPT
STRAINER INLET SIZE	1.07 IN (27 MM)

ENGINE SPECIFICATIONS	
MAKE/MODEL	HONDA/GX340
EMISSIONS	EPA CERTIFIED AND CARB PREEMPT
STARTING METHOD	RECOIL START
DESIGN	AIR-COOLED, 4 STROKE, SINGLE CYLINDER, OHV, HORIZONTAL SHAFT
DISPLACEMENT	337 CC (20.6 CU-IN)
BORE X STROKE	3.46 IN X 2.28 IN (88 MM X 64 MM)
HORSE POWER (kW)	10.7 (8.0)
ENGINE SPEED	3,600 RPM
GOVERNOR SPEED	MECHANICAL
SOUND LEVEL dB(A) AT 23 FT	77
AIR CLEANER	DUAL ELEMENT
LUBRICATION SYSTEM	SPLASH
SPARK ARRESTOR	STANDARD
OIL CAPACITY	1.16 QUARTS (1.10 LITERS)
OIL TYPE	SAE 10W-30
LOW OIL SHUT-DOWN	STANDARD

FUEL SPECIFICATIONS	
RECOMMENDED FUEL	UNLEADED GASOLINE
FUEL TANK CAPACITY	1.6 GALLONS (6.1 L)
FUEL CONSUMPTION	0.82 GPH (3.1 LPH)
RUN TIME	1.95 HOURS

WEIGHT AND DIMENSIONS	
DRY WEIGHT	221.6 LB (100.5 KG)
DIMENSIONS	27.9 x 25.0 x 28.1 IN (709 x 635 x 714 MM)

OPTIONS

SUCTION HOSES

- **HS420C** - 4" x 20 ft., 65psi, rigid PVC helix reinforced, NPS thread
- **HSQ420C** - 4" x 20 ft., 65psi, rigid PVC helix reinforced, NPT thread, Male Camlock, includes one quick disconnect coupler
- **HS425C** - 4" x 25 ft., 65psi, rigid PVC helix reinforced, NPS thread
- **HSQ425C** - 4" x 25 ft., 65psi, rigid PVC helix reinforced, NPT thread, Male Camlock, includes one quick disconnect coupler
- **A400A** - 4" type A coupler, male quick disconnect x female NPT



HS420C and HS425C

HSQ420C and HSQ425C

DISCHARGE HOSES

- **HD450C** - 4" x 50 ft., 60psi, NPS thread
- **HDQ450C** - 4" x 50 ft., 60psi, NPT thread, includes one quick disconnect coupler
- **A400A** - 4" type A coupler, male quick disconnect x female NPT



HD450C

HDQ450C

A400A

FILTER KIT

- **MKITPUMP-5** - (1) Air cleaner element, (1) spark plug, (5) flooding caps, (1) fuel filter

WHEEL KIT

- **UWK4** - Wheel kit with folding handles and flat free tires for easy transport

NOTICE Features and Specifications are subject to change without notice.