



# QPT305SLT

MULTIQUIP® 3" High Pressure Pump

## GALLONS PER MINUTE

**145 (549 L)**

## HEAD

**328 ft (100 M)**

## ENGINE

**Honda GX340**



## APPLICATIONS

Agricultural - Construction Sites - Emergency Response - Excavation, Farms, Fire Sprinklers - Fire Protection - Floods - High Head Requirements - Irrigation - Jetting - Jobsite Drainage - Landscaping - Mining - Municipalities - Oil & Gas - Standing Water - Swimming Pools - Quarries - Water Departments - Water Supply from Lakes/Rivers

## STANDARD FEATURES

- Maximum pumping capacity of **145 gallons (549 liters) per minute**
- Maximum lift of **25 feet (7.6 meters)**
- High-Efficiency impeller and volute for maximum fluid transfer
- Aluminum body and fittings
- Closed sand-cast aluminum impeller and volute for extreme high-pressure performance
- **1" (25.4 mm)** diameter fill and drain ports
- Ceramic carbon mechanical seal provides **extreme abrasion resistance** and **high temperature operation**
- **3-way discharge ports** can be used independently or simultaneously depending on the application
- Oil-alert to protect the engine in the case of low engine oil
- Heavy-duty **1" (25.4 mm) tubular steel frame** for transportation and pump protection

## WARRANTY\*

**QPT305SLT:** 24 months from date of purchase.

**Honda GX340 Engine:** 36 months from date of purchase.

**Hoses:** 3 months from date of purchase.

\*Refer to the MULTIQUIP NEW PRODUCT LIMITED WARRANTY FOR FULL TERMS AND CONDITIONS.

## FEATURES

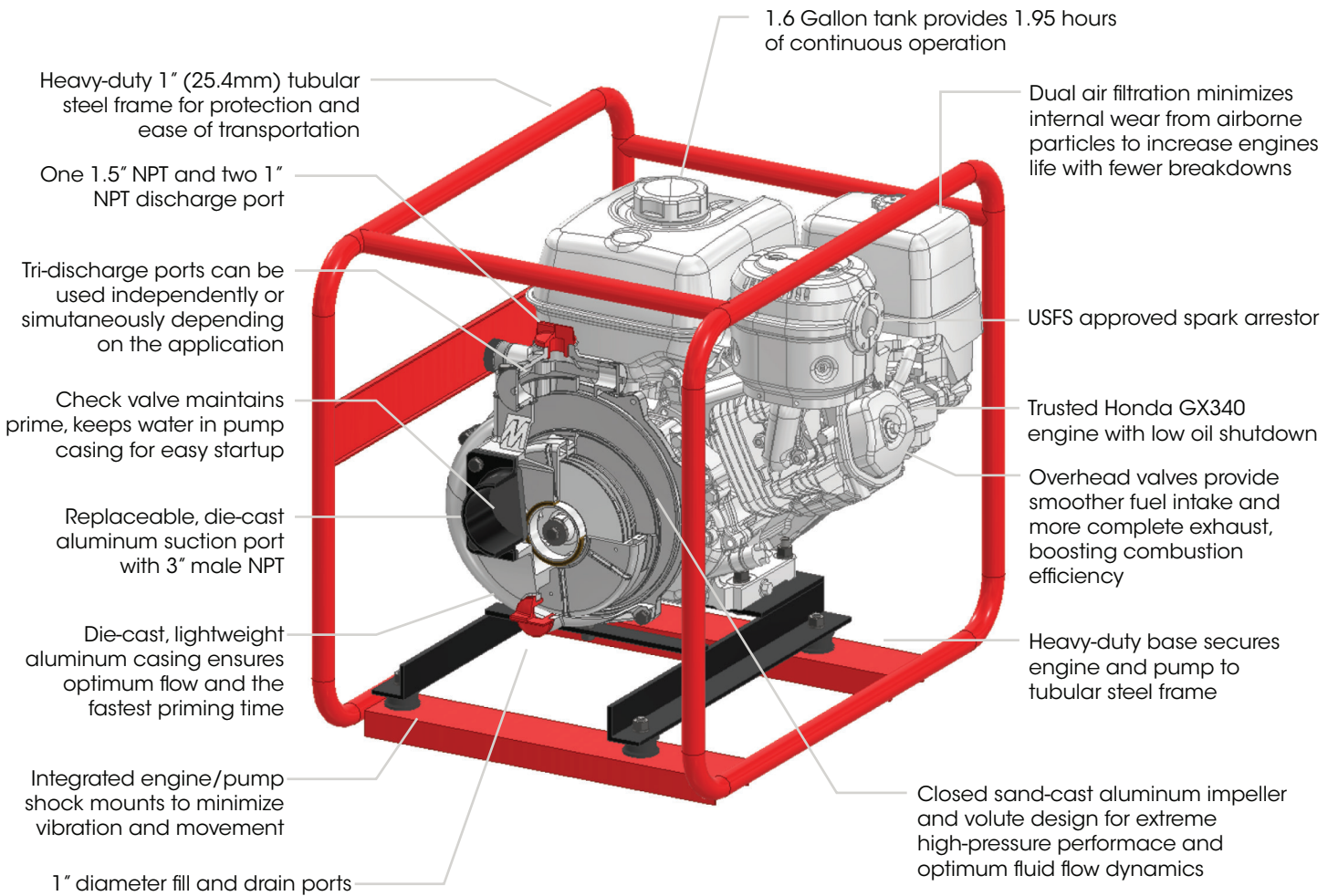

Enclosed sand-cast aluminum impeller and volute assembly create an impressive 142 psi system



Durable mechanical seal made of ceramic/carbon and 304 stainless steel to meet the rigorous demands of abrasion and high-temperature operation

## PUMP CURVE

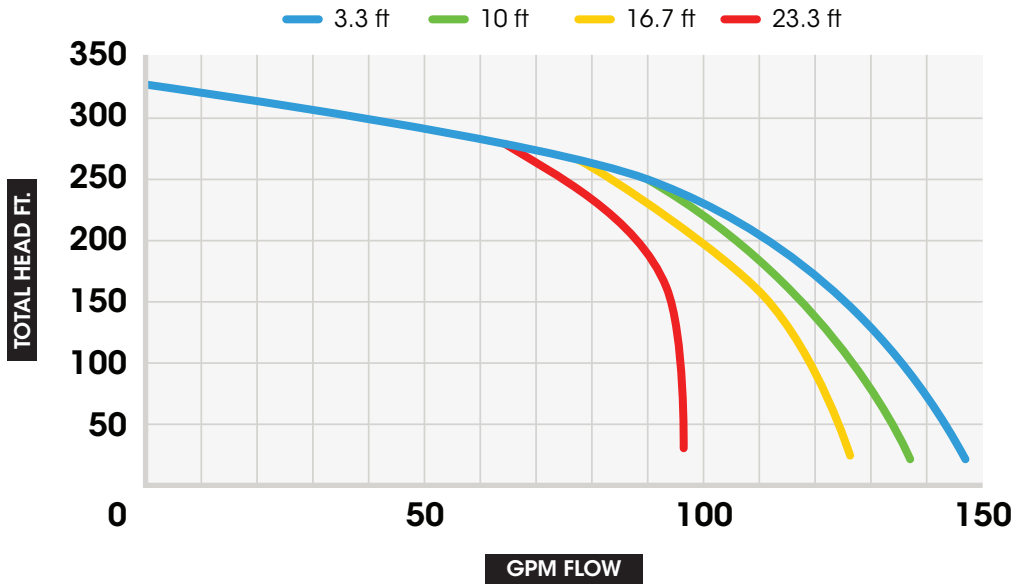

## PUMP DIMENSIONS

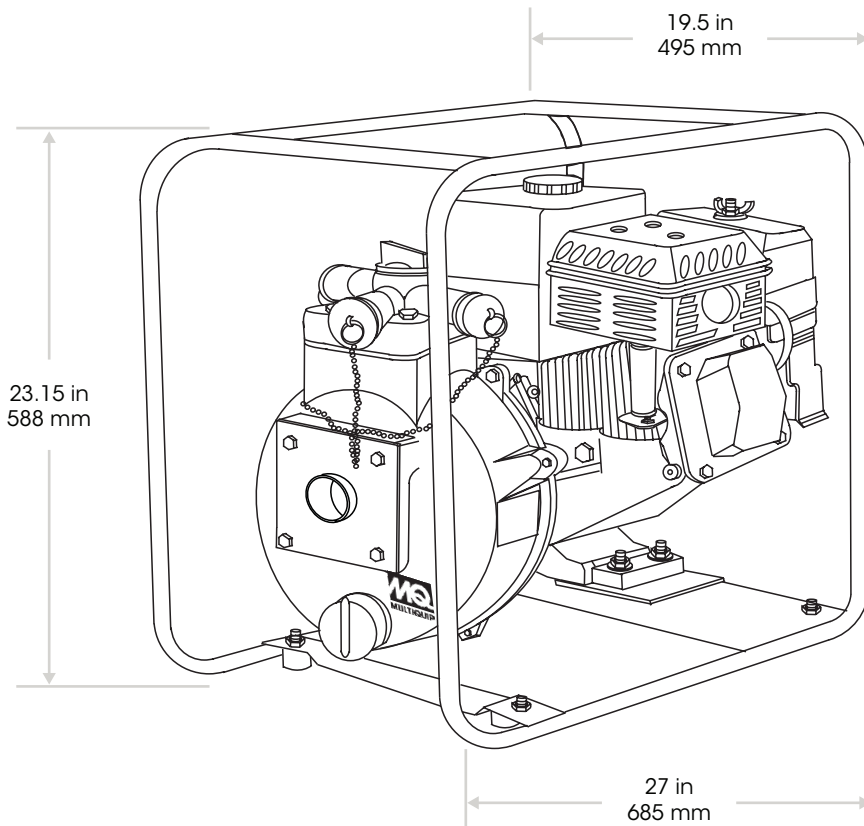

## SPECIFICATIONS

PUMP SPECIFICATIONS	
MODEL	QPT305SLT
TYPE	CENTRIFUGAL HIGH-PRESSURE PUMP
IMPELLER TYPE	CLOSED
MAX. PUMP CAPACITY	145 GALLONS/MINUTE (549 L/MIN)
MAX. SUCTION	25 FT (7.62 M)
MAX. HEAD	328 FT (100 M)
SUCTION PORT SIZE	3 IN (75 MM)
DISCHARGE PORT SIZE	1 X 1.50 IN (38.1 MM) 2 X 1.00 IN (25.4 MM)
THREAD TYPE	NPT (MALE)
PSI	142
IMPELLER MATERIAL	SAND-CAST ALUMINUM
VOLUTE MATERIAL	SAND-CAST ALUMINUM
PUMP CASING MATERIAL	DIE-CAST ALUMINUM
CHECK VALVE MATERIAL	NITRILE BUTADIENE RUBBER
MECHANICAL SEAL MATERIAL	CERAMIC/CARBON 304 STAINLESS STEEL
DRAIN AND FILL CAP MATERIAL	ACRYLONITRILE BUTADIENE STYRENE
SALT OR CHEMICALS	NO
PUMP HARDWARE	STEEL
MAX. FLUID TEMPERATURE	104° F (40° C)
MAX. SOLID HANDLING	0.18 IN (4.5 MM)
O-RINGS	NITRILE BUTADIENE RUBBER
STRAINER SIZE	3 IN (76.2 MM) NPT
STRAINER INLET SIZE	0.35 IN (9 MM) INCLUDES NYLON SET

ENGINE SPECIFICATIONS	
MAKE/MODEL	HONDA/GX340
EMISSIONS	EPA CERTIFIED AND CARB PREEMPT
STARTING METHOD	RECOIL START
DESIGN	AIR-COOLED, 4 STROKE, SINGLE CYLINDER, OHV, HORIZONTAL SHAFT
DISPLACEMENT	337 CC (20.6 CU-IN)
BORE X STROKE	3.46 IN X 2.28 IN (88 MM X 64 MM)
HORSE POWER (kW)	10.7 (8)
ENGINE SPEED	3,600 RPM
GOVERNOR SPEED	MECHANICAL
SOUND LEVEL dB(A) AT 23 FT	77
AIR CLEANER	DUAL ELEMENT
LUBRICATION SYSTEM	SPLASH
SPARK ARRESTOR	STANDARD
OIL CAPACITY	1.16 QUARTS (1.10 LITERS)
OIL TYPE	SAE 10W-30
LOW OIL SHUT-DOWN	STANDARD

FUEL SPECIFICATIONS	
RECOMMENDED FUEL	UNLEADED GASOLINE
FUEL TANK CAPACITY	1.6 GALLONS (6.1 L)
FUEL CONSUMPTION	0.82 GPH (3.1 LPH)
RUN TIME	1.95 HOURS

WEIGHT AND DIMENSIONS	
DRY WEIGHT	120 LB (54.5 KG)
DIMENSIONS	27 x 19.5 x 23.15 IN (685 x 495 x 588 MM)

**NOTICE** Features and Specifications are subject to change without notice.

## OPTIONS

### SUCTION HOSES

- **HS320C** - 3" x 20 ft., 65psi, rigid PVC helix reinforced, NPS thread
- **HSQ320C** - 3" x 20 ft., 65psi, rigid PVC helix reinforced, NPT thread, Male Camlock, includes one quick disconnect coupler
- **HS325C** - 3" x 25 ft., 65psi, rigid PVC helix reinforced, NPS thread
- **HSQ325C** - 3" x 25 ft., 65psi, rigid PVC helix reinforced, NPT thread, Male Camlock, includes one quick disconnect coupler
- **A300A** - 3" type A coupler, male quick disconnect x female NPT



HS320C and HS325C

HSQ320C and HSQ325C

### DISCHARGE HOSES

- **FIRENOZ15** - 1.5" Nozle, NPT thread
- **HDFNST** - 2.5" x 25 ft., 150psi, NPT thread, includes one quick disconnect coupler
- **A150A** - 1.5" type A coupler, male quick disconnect x female NPT



FIRENOZ15

HDFNST

A150A

### FILTER KIT

- **MKITPUMP-5** - (1) Air cleaner element, (1) spark plug, (5) flooding caps

### WHEEL KIT

- **UWKB** - Wheel kit with folding handles and flat free tires for easy transport

### SINGLE DISCHARGE PORT

- **KIT305SD** - (1) 3" Port, (1) 3" nipple with Male NPT, gaskets, and mounting hardware