

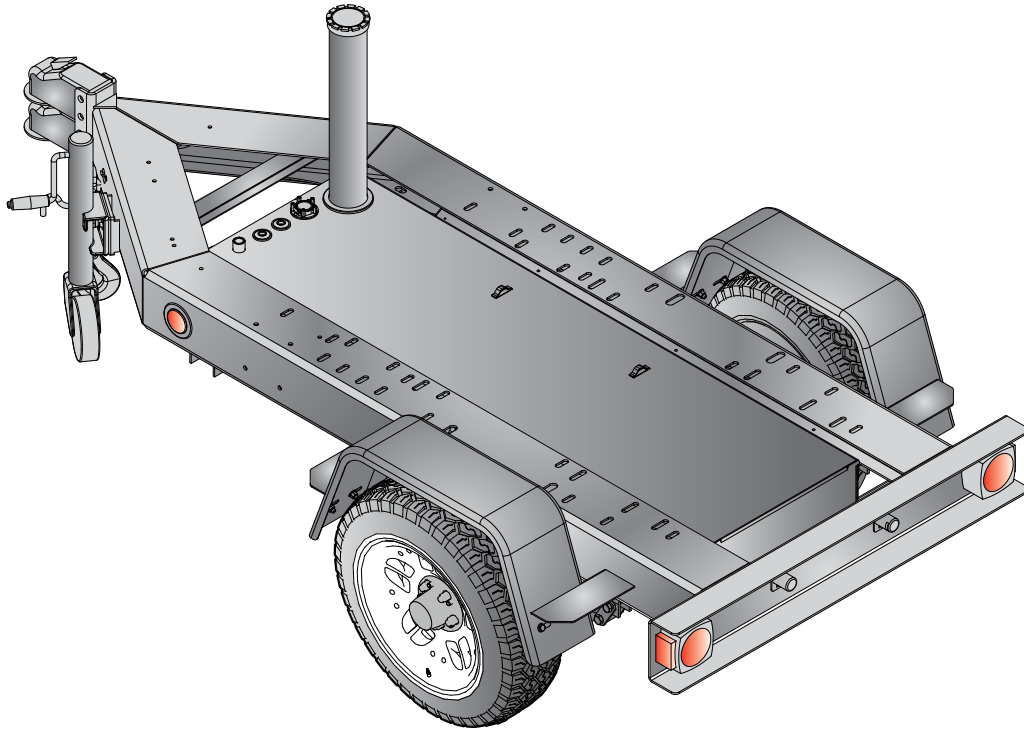

TRLRMPXF

Single Axle Trailer



TRLRMPXF Technical Data	
Gross Vehicle Weight Rating (GVWR) — 2,760 lbs (1,252 kg)	Tire Size — ST175/80R13 LR-C
Gross Axle Weight Rating (GAWR) — 3,500 lbs (1,587 kg) (ea.)	Wheel Bolt Pattern — 5 Lug on 4.5 in
Coupler Rating — See coupler options on back page.	Tire Load Rating — 1,380 lbs/626 kg (ea.)

STANDARD TRAILER EQUIPMENT

- Fits MQ Power Generator Models DAC6, DA7, DAC7, DCA10, DCA15, TLG8
- Single-axle Design with Leaf Spring Suspension
- Heavy-Duty Welded Steel Frame Construction
- Formed Channel for Generator Mounting and Support
- Integral Fuel Cell; Single-wall Steel Design, 28 Gallon Capacity
- 4-hole Channel Allows 3-position, Adjustable Coupler Height; 4-inches O/A
- Tongue Mounted Swivel Jack with Caster (rated 1,000 lbs. lift capacity)
- Replaceable, Bolt-on Steel Fenders
- Rugged Textured Black Powder Coat Paint Process including: Frame, Channel, and Fenders
- D.O.T. Approved Tail Lamps, Stop Lamps, Turn Signal Lamps, Side Marker Lamps
- Weatherproof, 3-piece Trailer Light Wiring Harness





TRLRMPXF

Single Axle Trailer

OPTIONAL TRAILER EQUIPMENT

- Electric-actuated Drum Brakes
- Anti-Theft Wheel Lock
- Front and Rear Stabilizer Stands
- Spare Tire with Locking Mount
- Tongue Mounted Storage Box

Coupler Options

2" Ball Coupler 10,000 lbs. #EE43254	
2-5/16" Ball Coupler 14,000 lbs. #EE43253	
3" Pintle Eye 25,000 lbs. #EE36264	

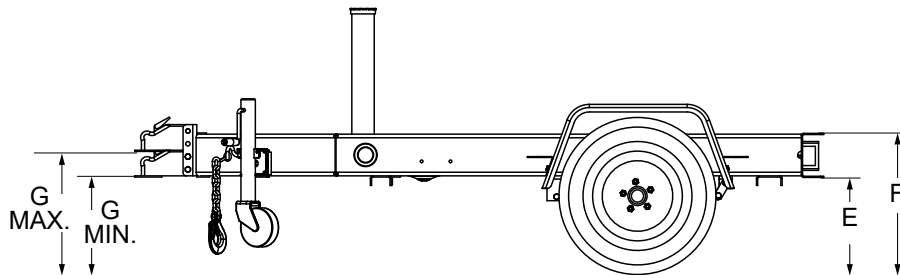
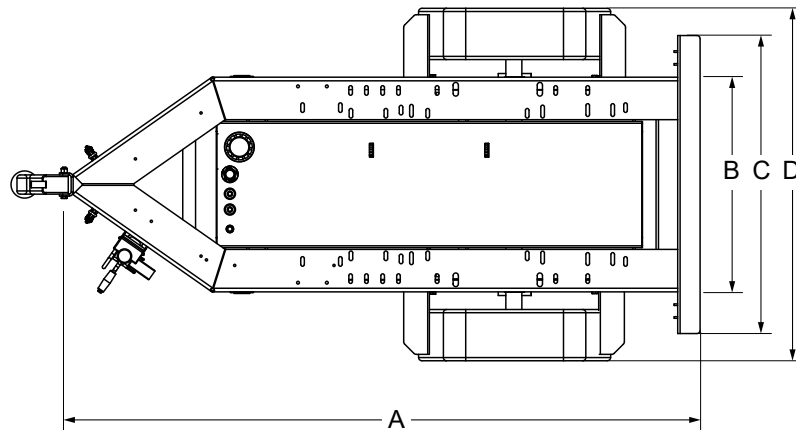

Trailer Dimensions							
A	B	C	D	E	F	G	
						Min	Max
99.97 in (2,539 mm)	33.5 in (851 mm)	46.5 in (1,181 mm)	55.25 in (1,403 mm)	15.5 in (394 mm)	21.46 in (545 mm)	14.64 in (372 mm)	18.64 in (473 mm)

Trailer Weight	
Without Fuel	With Fuel
513 lbs. (233 kg)*	713 lbs (323 kg)*

* Weight is approximate

