



WHL88TC Wheel Kit

Wheel Kit Installation Instructions

The following instructions are intended to assist the user in installing the WHL88TC Wheel Kit onto Multiquip MVC88VTH/VTHW Plate Compactors with serial number T2A9198 and above. This wheel kit is designed to make the transporting of the plate compactor easier. Please read the instructions before assembling.

REQUIRED TOOLS

- 3/8" Ratchet/Socket Set
- 17 mm Open-End Wrench
- Loctite™ #243, Blue

PARTS

Verify that all parts are accounted for. See Figure 1 and Table 1.

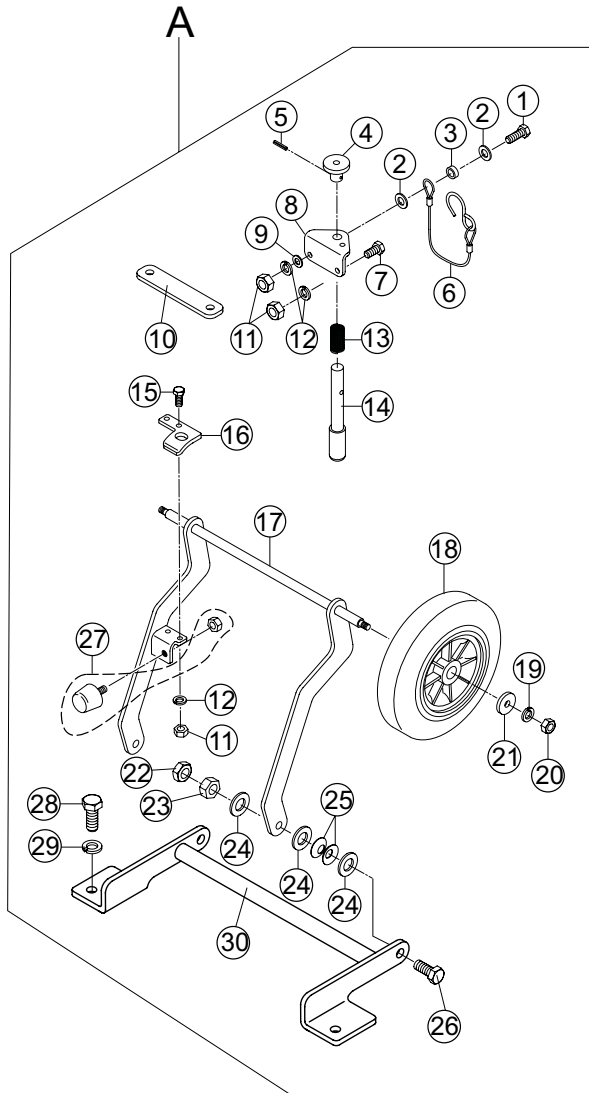

Figure 1. WHL88TC Kit Parts

Table 1. Kit Parts

Item No.	Part No.	Description	Qty.	Remarks
A	WHL88TC	Kit, Wheel	1	Includes items 1-30
1	011606025	Bolt, M6X25	1	
2	952408960	Washer, Flat	2	
3	952408980	Collar	1	
4	416467240	Lock Knob	1	
5	025403016	Spring Pin 3X16"	1	
6	419466670	Lock Wire	1	
7	0105050616	Bolt, M6X15	1	
8	416351700	Lock Holder	1	
9	952404470	Washer, Flat M6	1	
10	416466680	Spacer, Wheel	1	
11	020106050	Nut, M6	3	
12	030206150	Washer, Lock M6	3	
13	458450880	Spring	1	
14	416466690	Lock Pin	1	
15	011206020	Bolt, M6X20	1	
16	416467230	Stopper, Lock Pin	1	
17	416219520	Axle, Transport Wheel	1	
18	959301000	Wheel	2	
19	030208200	Washer, Lock M8	2	
20	020108060	Nut, M8	2	
21	952400130	Spacer	2	
22	020410060	Nut, M10	2	
23	020310080	Nut, M10	2	
24	031110160	Washer, Flat M10	6	
25	032110180	Conical, Lock Washer	4	
26	012210035	Bolt, M10X35	2	
27	939010270	Stopper, Rubber with Nut	1	
28	012010030	Bolt, M10X30	4	
29	030210250	Washer, Lock M10	4	
30	416352490	Bracket, Wheel	1	

WORK SAFELY!

Only a **qualified service technician** with proper training should perform this installation. Follow all shop safety rules when performing this installation.

GUARD HOOK REMOVAL

NOTICE

DO NOT reuse the existing M10X25 bolts and M10 lock washers that secure the guard hook to the engine base. These bolts are not long enough if the wheel kit is being installed.

The possibility exists of the compactor falling off the engine base when lifted.

- Using a 3/8" ratchet and 17 mm socket, remove the existing four M10 x 25 bolts that secure the guard hook to the engine base. Discard these four bolts and associated washers they will not be used again.

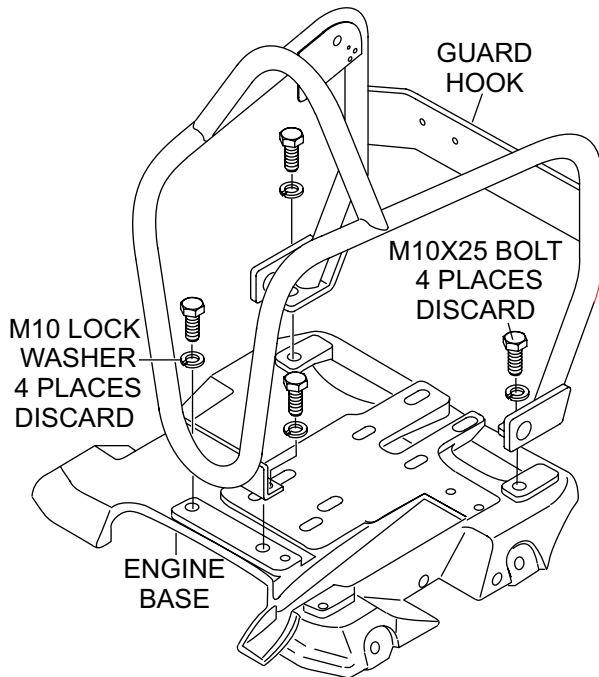

Figure 2. Guard Hook Removal

- Remove the guard hook from the engine base.

WHEEL SPACER AND WHEEL BRACKET INSTALLATION

- Place wheel spacer (item 10) onto engine base. Reference Figure 3.
- Next, place wheel bracket (item 30) onto engine base,
- Align guard hook with wheel spacer and wheel bracket.
- Using a 17 mm socket, secure wheel spacer to engine base using the two supplied M10X30 bolts (item 28) and M10 lock washers (item 29). Apply Blue Loctite™ #243 to bolt threads. Torque bolts to 54.2~57.9 ft·lbf (750~800 Kgf·cm).

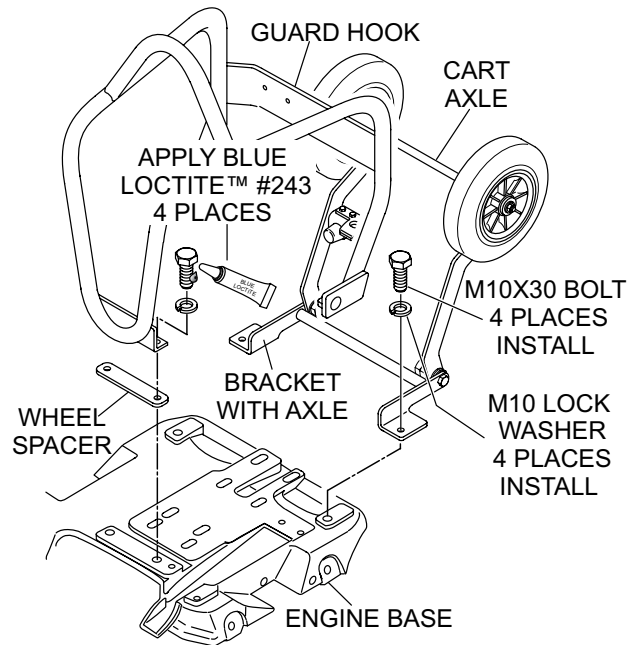

Figure 3. Wheel Spacer/Bracket Installation

- Using a 17 mm socket, secure wheel bracket (item 30) with axle using the two supplied 10X30 bolts (item 28) and lock washers (item 29). Apply Blue Loctite™ #243 to bolt threads. Torque bolts to 54.2~57.9 ft·lbf (750~800 Kgf·cm).

LOCK HOLDER INSTALLATION

NOTICE

Orientation of left and right is defined by standing at the rear of the machine (handle end). **DO NOT** use the shorter M6X15 bolt (item 7) on the right side.

- Using a 10 mm socket, secure the lock holder, item 8 (Figure 4) to the guard hook by inserting a M6X15 bolt, (item 7) through the left-side bolt hole opening.

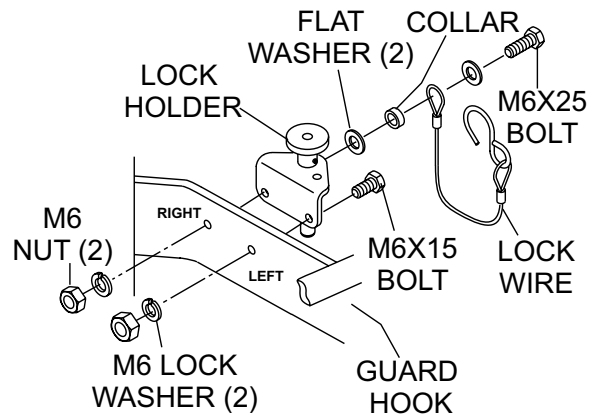

Figure 4. Lock Holder Installation

- Secure bolt with M6 lock washer (item 12) and M6 nut (item 11). Torque bolt to 10.8~13.0 ft-lbf (150~180 Kgf-cm).
- On the right-side of the the lock holder, insert a M6X25 bolt (item 1) through the bolt hole opening with 2 flat washers (item 2), lock wire (item 6) and collar (item 3).
- Secure bolt with M6 flat washer (item 9), M6 lock washer (item 12) and M6 nut (item 11). Torque bolt to 10.8~13.0 ft-lbf (150~180 Kgf-cm).

LOCK PIN ADJUSTMENT

- Grab hold of the lock pin knob (Figure 5) and pull upwards (unlocked position).

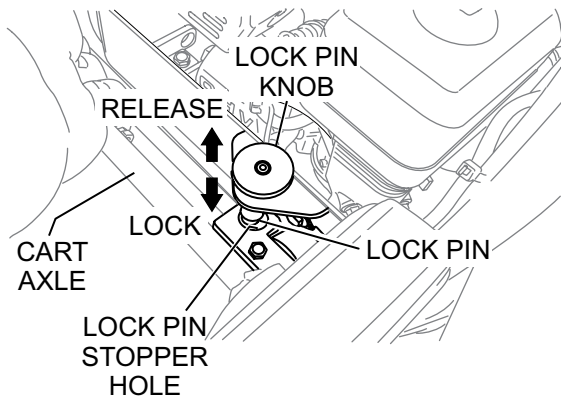

Figure 5. Lock Pin Adjustment

- Pull the cart axle bar all the upwards (stowed position) until it is fully engaged with lock pin (locked).

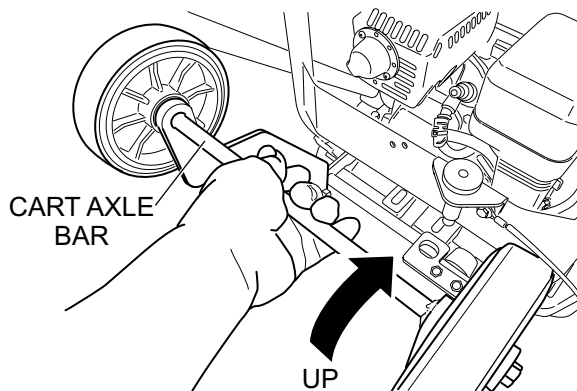

Figure 6. Placing Cart Axle in Stowed Position

- Verify that the lock pin fits into the lock pin stopper hole.
- If lock pin does not fully engage into lock pin stopper hole, rubber stopper will have to be adjusted.
- To adjust rubber stopper (item 25), use a 17 mm open-end wrench and loosen M8 adjustment nut (item 18). Reference Figure 7.

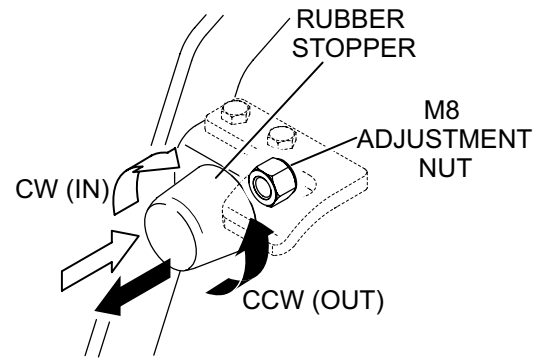

Figure 7. Rubber Stopper Adjustment

- Once the nut has been loosened, turn rubber stopper clockwise to move the stopper inward. Turning the stopper counterclockwise will move the stopper outward.
- Repeat steps 1 through 4 until the lock pin fits easily into the lock pin stopper hole.
- Tighten rubber stopper M8 adjustment nut.
- Place cart axle in the stowed position and insert lock pin.
- Pull down on the cart axle and verify that it will not become disengaged from the the lock pin.

CART AXLE SPEED ADJUSTMENT

There may be a need to adjust the deployment speed of the cart axle when released by the lock pin. The cart deployment speed is controlled by the adjustment of the disc spring.

Use the procedure below to adjust the speed of the axle assembly.

- Grab hold of the lock pin knob and pull upwards (unlocked position).
- Pull down on the cart axle and verify how long it takes to touch the ground surface.
- If the cart axle hits the ground immediately, adjustment is necessary.
- There are two M10 nuts (Figure 8) on each side of the cart axle that secure it to the wheel bracket.

- Using a 17 mm socket, loosen both inner and outer M10 nuts (items 22 and 23) on one side of the cart axle.

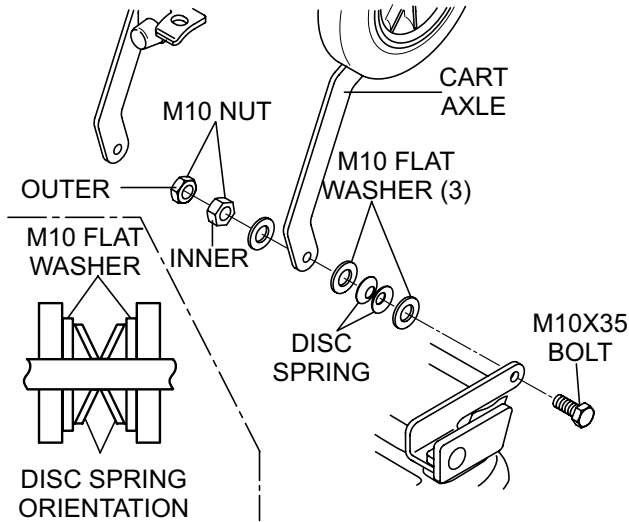

Figure 8. Cart Axle Adjustment

- Adjust/tighten inner nut until desired cart axle deployment speed is achieved.
- Install outer M8 nut and tighten.
- Repeat steps 1 through 7 for other end of cart axle.

CART OPERATION

Cart Axle Deployment

The following procedure details how to place the axle cart in the transport position.

- Unhook the lock wire (item 6) hook from the lock holder. Reference Figure 9.

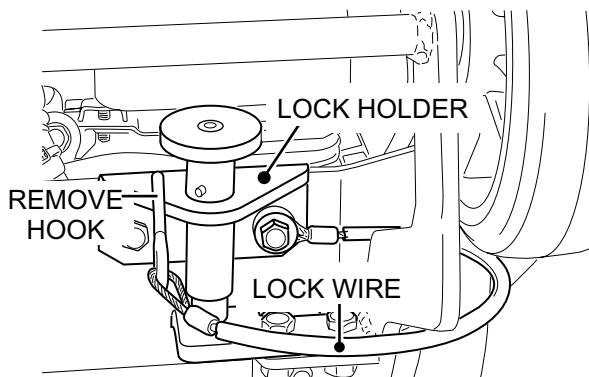

Figure 9. Removing Lock Wire

- Grab hold of the lock knob (Figure 10) and pull upwards (unlocked position).

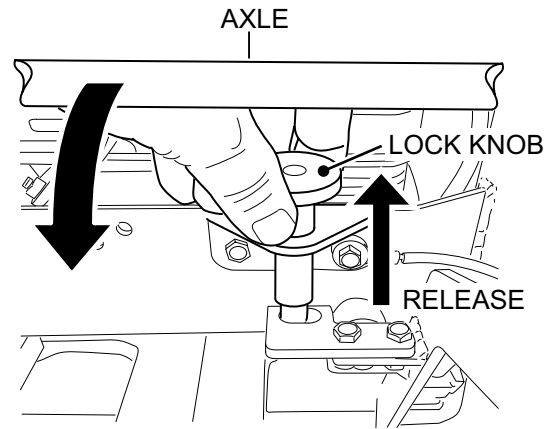

Figure 10. Lock Knob Release

- Let the cart axle deploy and touch the ground.
- Place the lock wire around the handle body as shown in Figure 11.

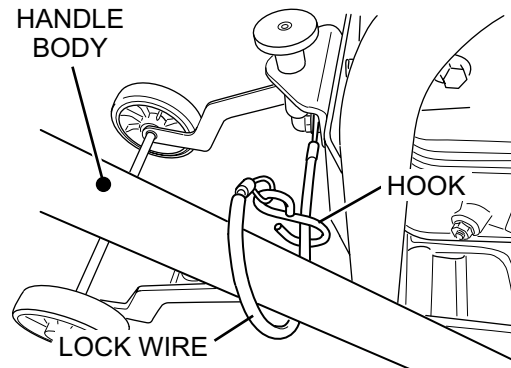

Figure 11. Lock Wire Attachment

- Place foot on top of axle cart bar (Figure 12) and push upward on the handle body, then tilt compactor forward until both wheels are positioned underneath the compactor plate.

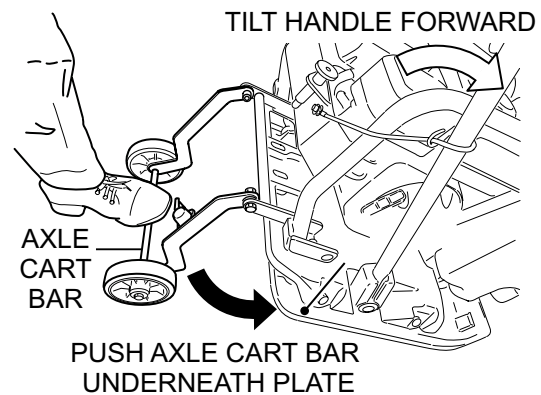

Figure 12. Positioning Axle Cart Bar (Transport)

- Pull back and push down on the handle (Figure 13), then raise the compactor slightly. Compactor is now ready for transport.

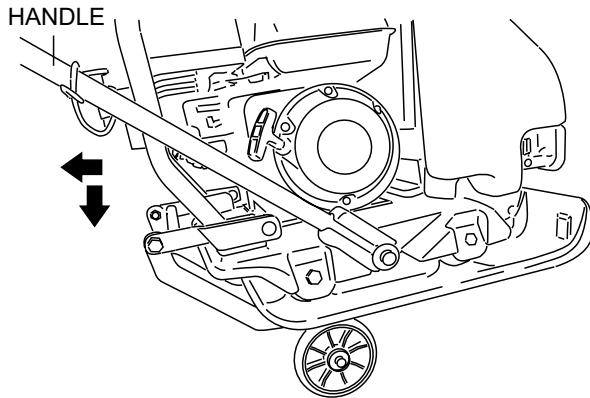

Figure 13. Transporting The Compactor

Cart Axle Stowed Position

The following procedure details how to place the axle cart in the stowed position.

- Push plate compactor handle upward/forward tilting the compactor until the vibrating plate (Figure 14) touches the ground.

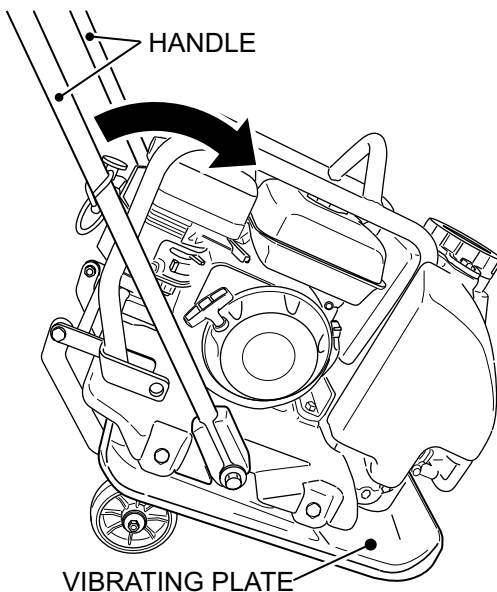

Figure 14. Tilting the Compactor

- Continue tilting the compactor until the wheels move away from the rear of the machine.
- Once the wheels have been positioned away from the rear of the compactor, place your foot (Figure 15) underneath the cart axle bar so that the cart can be raised.

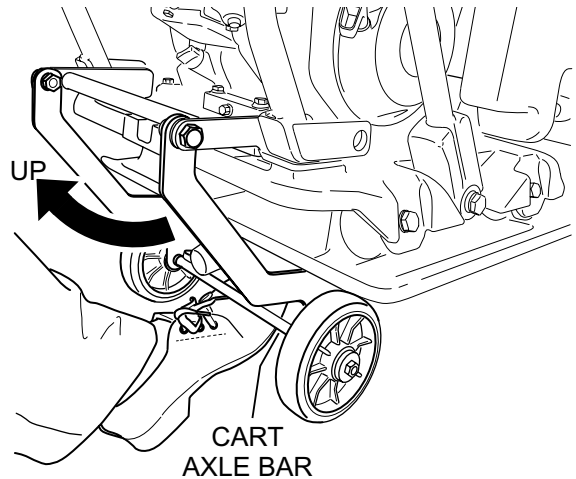

Figure 15. Raising Axle Bar (Foot)

- With your hand, grab hold of the cart axle bar (Figure 16) and pull upwards. Continue pulling cart axle upwards until cart is secured to guard hook by the automatic locking pin.

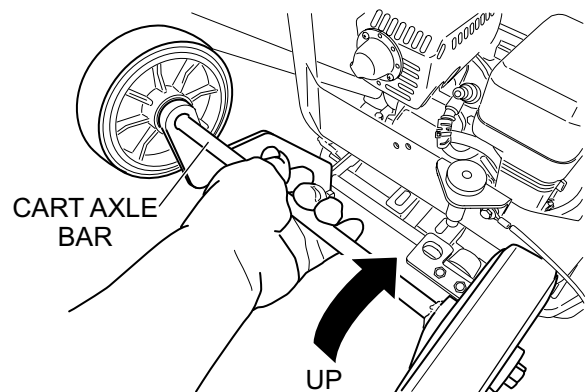

Figure 16. Positioning Axle Cart Bar (Stowed)

- Remove lock wire from handle body and attach to lock holder hole.

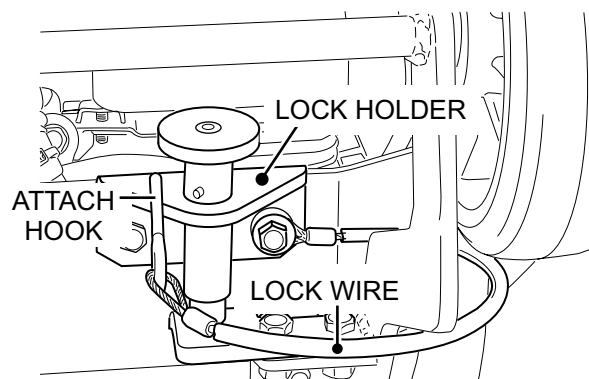

Figure 17. Attaching The Lock Wire

- Compactor is now ready for use.



WHL88TC Wheel Kit

Wheel Kit Installation Instructions

HERE'S HOW TO GET HELP

PLEASE HAVE THE MODEL AND SERIAL
NUMBER ON-HAND WHEN CALLING

UNITED STATES

Multiquip Corporate Office

18910 Wilmington Ave. Tel. (800) 421-1244
Carson, CA 90746 Fax (310) 537-3927
Contact: mq@multiquip.com

Service Department

800-421-1244 Fax: 310-537-4259
310-537-3700

Technical Assistance

800-478-1244 Fax: 310-943-2238

MQ Parts Department

800-427-1244 Fax: 800-672-7877
310-537-3700 Fax: 310-637-3284

Warranty Department

800-421-1244 Fax: 310-943-2249
310-537-3700

CANADA

Multiquip

4110 Industriel Boul. Tel: (450) 625-2244
Laval, Quebec, Canada H7L 6V3 Tel: (877) 963-4411
Contact: jmartin@multiquip.com Fax: (450) 625-8664

UNITED KINGDOM

Multiquip (UK) Limited Head Office

Unit 2, Northpoint Industrial Estate, Tel: 0161 339 2223
Globe Lane, Fax: 0161 339 3226
Dukinfield, Cheshire SK16 4UJ
Contact: sales@multiquip.co.uk

© COPYRIGHT 2015, MULTIQUIP INC.

Multiquip Inc and the MQ logo are registered trademarks of Multiquip Inc. and may not be used, reproduced, or altered without written permission. All other trademarks are the property of their respective owners and used with permission.

The information and specifications included in this publication were in effect at the time of approval for printing. Illustrations, descriptions, references and technical data contained in this document are for guidance only and may not be considered as binding. Multiquip Inc. reserves the right to discontinue or change specifications, design or the information published in this publication at any time without notice and without incurring any obligations.

Your Local Dealer is:

