

# OPERATION MANUAL



**MODELS**  
**WT5C/WTE5C**  
**WT5CSG/WTE5CSG**  
**WT5CYC/WTE5CYC**  
**WATER TRAILERS**  
**(HONDA GX120UT3PX2 GASOLINE ENGINE)**  
**(QP2HLF CENTRIFUGAL PUMP)**

Revision #6 (05/28/21)

To find the latest revision of this publication or associated parts manual, visit our website at:  
[www.multiquip.com](http://www.multiquip.com)



**THIS MANUAL MUST ACCOMPANY THE EQUIPMENT AT ALL TIMES.**

**PN 49858**

# PROPOSITION 65 WARNING

---





# TABLE OF CONTENTS

---

## **WT5C Series Water Trailer**

Proposition 65 Warning .....	2
Table Of Contents .....	4
Safety Information .....	5-9
Specifications (Pump/Trailer).....	10
Specifications (Engine).....	11
Dimensions.....	12
General Information.....	13
Components (Water Trailer).....	14-15
Basic Engine.....	16
Inspection .....	17
Operation.....	18-24
Winterizing Procedure .....	25-26
Maintenance .....	27-35
Trailer Safety Guidelines.....	36-50
Troubleshooting (Pump) .....	51
Troubleshooting (Engine).....	52

# SAFETY INFORMATION

Do not operate or service the equipment before reading the entire manual. Safety precautions should be followed at all times when operating this equipment. Failure to read and understand the safety messages and operating instructions could result in injury to yourself and others.









## SAFETY MESSAGES

The four safety messages shown below will inform you about potential hazards that could injure you or others. The safety messages specifically address the level of exposure to the operator and are preceded by one of four words: **DANGER**, **WARNING**, **CAUTION** or **NOTICE**.

## SAFETY SYMBOLS

 <b>DANGER</b>
Indicates a hazardous situation which, if not avoided, <b>WILL</b> result in <b>DEATH</b> or <b>SERIOUS INJURY</b> .
 <b>WARNING</b>
Indicates a hazardous situation which, if not avoided, <b>COULD</b> result in <b>DEATH</b> or <b>SERIOUS INJURY</b> .
 <b>CAUTION</b>
Indicates a hazardous situation which, if not avoided, <b>COULD</b> result in <b>MINOR</b> or <b>MODERATE INJURY</b> .
<b>NOTICE</b>
Addresses practices not related to personal injury.

Potential hazards associated with the operation of this equipment will be referenced with hazard symbols which may appear throughout this manual in conjunction with safety messages.

Symbol	Safety Hazard
	Lethal exhaust gas hazards
	Explosive fuel hazards
	Burn hazards
	Respiratory hazards
	Accidental starting hazards
	Eye and hearing hazards
	Pressure hazards

# SAFETY INFORMATION

## GENERAL SAFETY

### CAUTION

- **NEVER** operate this equipment without proper protective clothing, shatterproof glasses, respiratory protection, hearing protection, steel-toed boots and other protective devices required by the job or city and state regulations.



- Avoid wearing jewelry or loose-fitting clothes that may snag on the controls or moving parts as this can cause serious injury.

- **NEVER** operate this equipment when not feeling well due to fatigue, illness or when on medication.



- **NEVER** operate this equipment under the influence of drugs or alcohol.



- **ALWAYS** clear the work area of any debris, tools, etc. that would constitute a hazard while the equipment is in operation.

- No one other than the operator is to be in the working area when the equipment is in operation.

- **DO NOT** use the equipment for any purpose other than its intended purposes or applications.

### NOTICE

- This equipment should only be operated by trained and qualified personnel 18 years of age and older.

- Whenever necessary, replace nameplate, operation and safety decals when they become difficult to read.

- Manufacturer does not assume responsibility for any accident due to equipment modifications. Unauthorized equipment modification will void all warranties.

- **NEVER** use accessories or attachments that are not recommended by Multiquip for this equipment. Damage to the equipment and/or injury to user may result.

- **ALWAYS** know the location of the nearest fire extinguisher.



- **ALWAYS** know the location of the nearest first aid kit.



- **ALWAYS** know the location of the nearest phone or **keep a phone on the job site**. Also, know the phone numbers of the nearest **ambulance, doctor** and **fire department**. This information will be invaluable in the case of an emergency.



# SAFETY INFORMATION

## PUMP SAFETY

### DANGER

- **NEVER** operate the equipment in an explosive atmosphere or near combustible materials. An explosion or fire could result causing **severe bodily harm or even death.**



### WARNING

- Accidental starting can cause severe injury or death. **ALWAYS** place the ON/OFF switch in the OFF position.



- **DO NOT** place hands or fingers inside the pump when the pump is running.



- **NEVER** disconnect any **emergency or safety devices.** These devices are intended for operator safety. Disconnection of these devices can cause severe injury, bodily harm or even death. Disconnection of any of these devices will void all warranties.

### CAUTION

- Be careful of discharge whipping under pressure.

### NOTICE

- **NEVER** leave an open pump chamber unattended.
- **ALWAYS** keep the machine in proper running condition.
- **DO NOT** attempt to thaw out a frozen pump by using a torch or other source of flame. Application of heat in this manner may heat the oil in the seal cavity above the critical point, causing pump damage.
- **DO NOT** pump water greater than 140°F.
- **DO NOT** pump liquids containing acid or alkali.
- **DO NOT** fill/pump heavy debris laden water.
- Fix damage to machine and replace any broken parts immediately.

- **ALWAYS** store equipment properly when it is not being used. Equipment should be stored in a clean, dry location out of the reach of children and unauthorized personnel.

- **NEVER** lubricate components or attempt service on a running machine.

- **ALWAYS** allow the machine a proper amount of time to cool before servicing.

- Keep machine in proper running condition.

## ENGINE SAFETY

### WARNING

- **DO NOT** place hands or fingers inside engine compartment when engine is running.

- **NEVER** operate the engine with heat shields or guards removed.

- **DO NOT** remove the engine oil drain plug while the engine is hot. Hot oil will gush out of the oil tank and severely scald any persons in the general area of the pump.



### CAUTION

- **NEVER** touch the hot exhaust manifold, muffler or cylinder. Allow these parts to cool before servicing equipment.



### NOTICE

- **NEVER** run engine without an air filter or with a dirty air filter. Severe engine damage may occur. Service air filter frequently to prevent engine malfunction.

- **NEVER** tamper with the factory settings of the engine or engine governor. Damage to the engine or equipment can result if operating in speed ranges above the maximum allowable.



# SAFETY INFORMATION

## FUEL SAFETY

### DANGER

- **DO NOT** start the engine near spilled fuel or combustible fluids. Fuel is extremely flammable and its vapors can cause an explosion if ignited.
- **ALWAYS** refuel in a well-ventilated area, away from sparks and open flames.
- **ALWAYS** use extreme caution when working with **flammable** liquids.
- **DO NOT** fill the fuel tank while the engine is running or hot.
- **DO NOT** overfill tank, since spilled fuel could ignite if it comes into contact with hot engine parts or sparks from the ignition system.
- Store fuel in appropriate containers, in well-ventilated areas and away from sparks and flames.
- **NEVER** use fuel as a cleaning agent.
- **DO NOT** smoke around or near the equipment. Fire or explosion could result from fuel vapors or if fuel is spilled on a hot engine.



## TOWING SAFETY

### CAUTION

- Check with your local county or state safety towing regulations, in addition to meeting **Department of Transportation (DOT) Safety Towing Regulations**, before towing your water trailer.
- In order to reduce the possibility of an accident while transporting the water trailer on public roads, **ALWAYS** make sure the trailer and the towing vehicle are mechanically sound and in good operating condition.
- **ALWAYS** shut down engine before transporting.
- Make sure the hitch and coupling of the towing vehicle are rated equal to, or greater than the trailer “gross vehicle weight rating.”



- **ALWAYS** inspect the hitch and coupling for wear. **NEVER** tow a trailer with defective hitches, couplings, chains, etc.
- Check the tire air pressure on both towing vehicle and trailer. **Trailer tires should be inflated to 50 psi cold.** Also check the tire tread wear on both vehicles.
- **ALWAYS** make sure the trailer is equipped with a **safety chain**.
- **ALWAYS** properly attach trailer’s safety chains to towing vehicle.
- **ALWAYS** make sure the vehicle and trailer directional, backup, brake and trailer lights are connected and working properly.
- DOT Requirements include the following:
  - Connect and test electric brake operation.
  - Secure portable power cables in cable tray with tie wraps.
- The maximum speed for highway towing is **55 MPH** unless posted otherwise. Recommended off-road towing is not to exceed **15 MPH** or less depending on type of terrain.
- Avoid sudden stops and starts. This can cause skidding or jack-knifing. Smooth, gradual starts and stops will improve towing.
- Avoid sharp turns to prevent rolling.
- For Hydraulic Brake Models **ALWAYS** ensure that when backing up it is done in a slow, straight, and steady manner to safeguard the brakes from locking up.
- Trailer should be adjusted to a level position at all times when towing.
- Raise and lock trailer wheel stand in up position when towing.
- Place **chock blocks** underneath wheels to prevent **rolling** while parked.
- Place **support blocks** underneath the trailer’s bumper to prevent **tipping** while parked.
- Use the trailer’s swivel jack to adjust the trailer height to a level position while parked.



## ENVIRONMENTAL SAFETY/DECOMMISSIONING

### NOTICE

Decommissioning is a controlled process used to safely retire a piece of equipment that is no longer serviceable. If the equipment poses an unacceptable and unrepairable safety risk due to wear or damage or is no longer cost effective to maintain (beyond life-cycle reliability) and is to be decommissioned (demolition and dismantlement), be sure to follow rules below.

- **DO NOT** pour waste or oil directly onto the ground, down a drain, or into any water source.
- Contact your country's Department of Public Works or recycling agency in your area and arrange for proper disposal of any electrical components, waste or oil associated with this equipment.
- When the life cycle of this equipment is over, remove battery, if any, and bring to appropriate facility for lead reclamation. Use safety precautions when handling batteries that contain sulfuric acid.
- When the life cycle of this equipment is over, it is recommended that the water trailer frame and all other metal parts be sent to a recycling center.



Metal recycling involves the collection of metal from discarded products and its transformation into raw materials to use in manufacturing a new product.

Recyclers and manufacturers alike promote the process of recycling metal. Using a metal recycling center promotes energy cost savings.

## EMISSIONS INFORMATION

### NOTICE

The gasoline engine used in this equipment has been designed to reduce harmful levels of carbon monoxide (CO), hydrocarbons (HC) and nitrogen oxides (NOx) contained in gasoline exhaust emissions.

This engine has been certified to meet US EPA evaporative emissions requirements in the installed configuration.

Attempting to modify or make adjustments to the engine emission system by unauthorized personnel without proper training could damage the equipment or create an unsafe condition.

Additionally, modifying the fuel system may adversely affect evaporative emissions, resulting in fines or other penalties.

### Emission Control Label

The emission control label is an integral part of the emission system and is strictly controlled by regulation(s).

The label must remain with the engine for its entire life.

If a replacement emission label is needed, please contact your authorized Honda Engine Distributor.

## SPECIFICATIONS (PUMP/TRAILER)

Table 1. Specifications		
<b>Water Tank</b>	Type	Low Profile
	Style	Rotomolded - Seamless with Baffles
	Fill Port	12" - Vented Port
	Material	Polypropylene - 1/4" Wall - Repairable
	Fill Rate	5 min. Full (Fill at Full Throttle)
	Capacity	525 gallons (1,987 liters)
	Weight w/ Empty Water Tank	1,530 lbs. (694 kg)
	Weight w/ Full Water Tank	5,835 lbs. (2,647 kg)
<b>Pump</b>	Type	2" (51 mm) Centrifugal
	Maximum Flow	158 GPM (600 LPM)
	Maximum Head	115 ft. (35 meters)
	Dry Net Weight	53 lbs. (24 kg)
<b>Trailer and Frame</b>	Material	Formed Steel Channel Frame
	Number of Axles	2
	Capacity - Axle Rating	3,500 lbs. (1,567 kg) ea.
	Tires	ST205/75D 14"
	Certifications	DOT
	Brakes (Model WT5C)	Surge Hydraulic-Actuated Drum Brakes
	Brakes (Model WTE5C)	Electric-Actuated Drum Brakes
	Hitch	2-5/16" ball
	Jack	2,000 lbs. (907 kg)
	Hose Bin	Formed Steel
<b>Water Operations</b>	Delivery Methods	Pressurized 1.5" and 2" Left/2" Right Two Std. Garden Hose Adapters: Adapter #1 Pressurized (Upper) Adapter #2 Drain Only (Lower) Pressurized Rear Spray Nozzles
	Fill Methods	Municipal Fire Hydrant - QD 1.5" and 2" QD Cam and Groove Adapter Two Std. Garden Hose Adapters

## SPECIFICATIONS (ENGINE)

<b>Table 2. Specifications (Engine)</b>	
<b>Model</b>	<b>Honda GX120UT3PX2</b>
Type	Air-cooled, 4-stroke, Single Cylinder, OHV, Horizontal Shaft Gasoline Engine
Bore x Stroke	2.36 in. x 1.65 in. (60 mm x 42 mm)
Displacement	7.2 cu-in. (118 cc)
Max. Output	3.5 H.P. @ 3,600 RPM
Fuel Tank Capacity	0.66 U.S. Gallons (2.0 Liters)
Fuel	Unleaded Gasoline
Fuel Consumption - Net Prime	0.18 GPH (0.68 LPH)
Lube Oil Capacity	0.63 qt. (0.6 liters)
Oil Type	4-Stroke API, SF or SG SAE 10W-30 General Use
Speed Control Method	Centrifugal Flyweight Type
Cooling System	Forced Air
Starting Method	Recoil Start
Spark Plug Type	BPR6ES NGK
Spark Plug Gap	0.028–0.031 in. (0.70–0.80 mm)
Dimensions (L x W x H)	12.0 x 13.6 x 12.9 in. (306 x 346 x 329 mm)
Dry Net Weight	28.6 lbs. (13 kg)

# DIMENSIONS

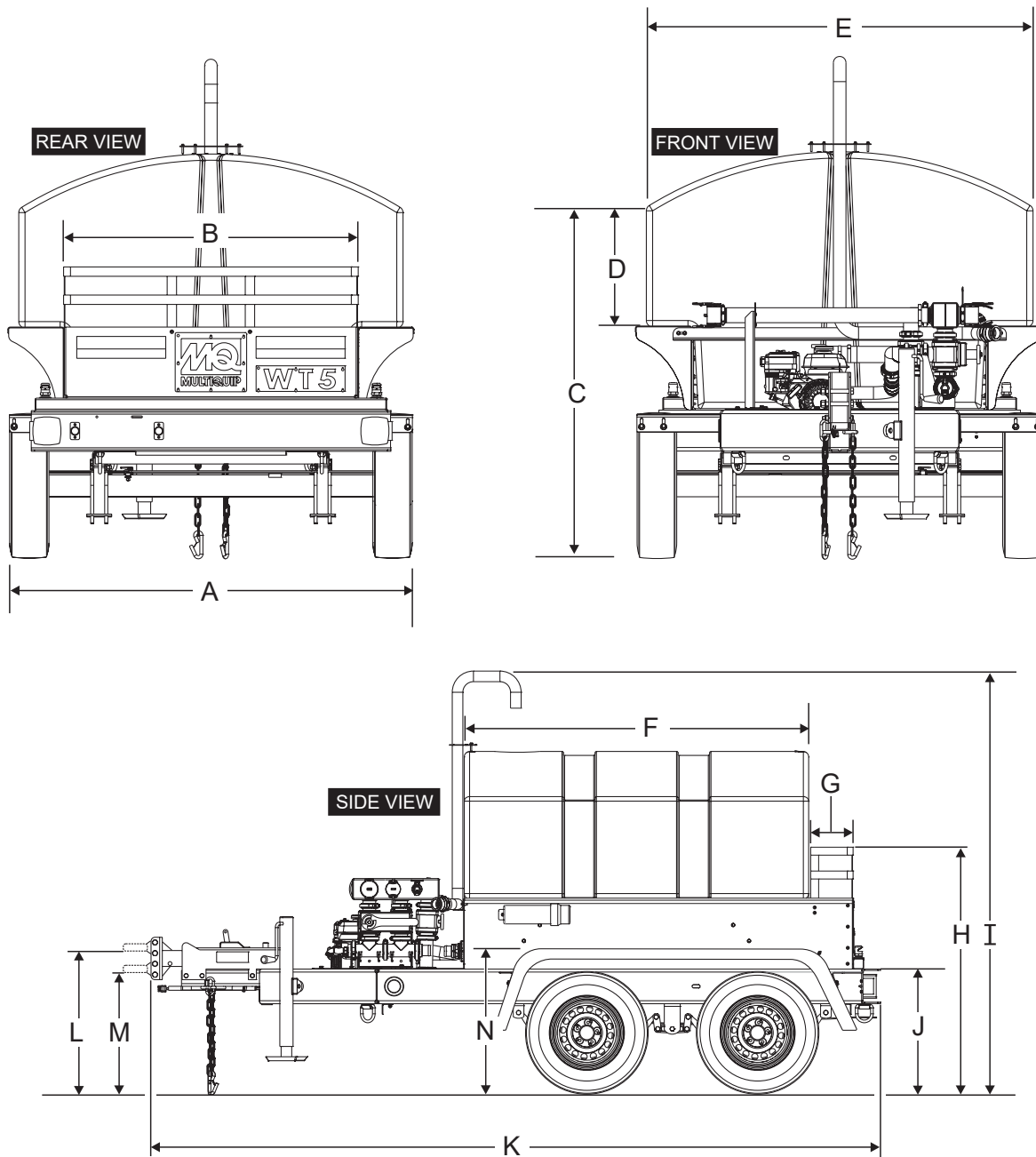

Figure 1. Dimensions

Table 3. Dimensions

Reference Letter	Dimension in (mm)	Reference Letter	Dimension in (mm)	Reference Letter	Dimension in (mm)	Reference Letter	Dimension in (mm)
A	69.50 (1,765)	E	60.50 (1,537)	I	80.00 (2,032)	M	18.70 (475)
B	47.25 (1,200)	F	64.00 (1,626)	J	25.00 (635)	N	31.5 (800)
C	58.00 (1,473)	G	8.00 (203)	K <sup>1</sup>	142.50 (3,619)		
D	20.00 (508)	H	46.5 (1,181)	L	22.70 (577)		

For total length add approximately 3.5 in. (90 mm) for coupler length.

## APPLICATION

Typical applications for Multiquip's Water Trailers include: dust control, emergency fire fighting response, construction, agricultural support and equipment wash down.

The WT5C Series are industrial 525-gallon Water Trailers. Each water trailer comes with a centrifugal pump, flexible suction/discharge manifold system with simple valve controls, and a rugged polypropylene water tank.

## Manifold System

- 1.5" CAM and groove QD
- 2.0" CAM and groove QD left and right sides (discharge)
- 2.0" CAM and groove QD water tank fill (suction)
- 3-position manifold control lever Off-Suction-Discharge
- 2-position spray bar control lever On-Off
- Three 3/4" garden hose bibs

## Water Tank

Water tank capacity is 525 gallons (1,987 liters). Tank is made of durable 3/16" wall polypropylene with integrated baffles to reduce water movement during transportation.

Water tank can be quickly filled via 2" diameter steel pipe with 2" QD coupler or vented 12" diameter port. In addition, water tank has a rear spray bar that operates under pressurized or gravity feed settings.

Additional features also include two standard garden hose valves (fill/discharge and tank drain).

## Trailer and Frame

The trailer is a DOT-approved, double-axle trailer. Trailers can be ordered with either a standard hydraulic surge brake system or electric brake system. Trailers can be configured with various hitch options.

For convenience, a formed steel hose bin has been provided for the storage of hoses and accessories during transport.

## Pump

The Multiquip QP2HLF Centrifugal Pump, which is used in conjunction with the water trailer, has the capability to pump at a rate of approximately 158 gallons/minute (gpm) or 600 liters/minute (lpm).

Centrifugal or self priming pumps are designed to purge air from the suction line and create a partial vacuum in the pump body.

The reduced atmospheric pressure inside the pump allows water to flow through the suction line and into the pump body. The centrifugal force created by the rotating impeller pressurizes the water and expels it from the pump.

This centrifugal pump should only be used in clear water applications (agricultural, industrial, residential) as it only has a limited solid handling capability of only 10% by volume.

## Elevation

Higher elevations will effect the performance of the pump. Due to less atmospheric pressure at higher altitudes, pumps **DO NOT** have the priming ability that they have at sea level. This is due to the "thinner air" or lack of oxygen at higher altitudes.

## Power Plant

The centrifugal pump, used by the water trailer, is powered by a 3.5 horsepower, air-cooled, 4-stroke, single-cylinder, HONDA GX120 gasoline engine that incorporates a low "Oil Alert Feature."

## Oil Alert Feature

In the event of low oil or no oil, the HONDA GX120 engine has a built-in oil shut-down feature. In the event the oil level is low the engine will automatically shut down and cannot be restarted until the oil level is brought up to a safe operating level.

## Accessories (Optional Items)

- Suction Hose - NPT Thread
- Suction Hose - Quick Disconnect Coupler
- Discharge Hose - NPT Thread
- Discharge Hose - Quick Disconnect Coupler
- Discharge Hose - Fire Hydrant
- Aluminum Couplers - QD
- Fire Hose Nozzle

Contact your nearest Multiquip dealer for any hoses or accessories that you may need.

# COMPONENTS (WATER TRAILER)

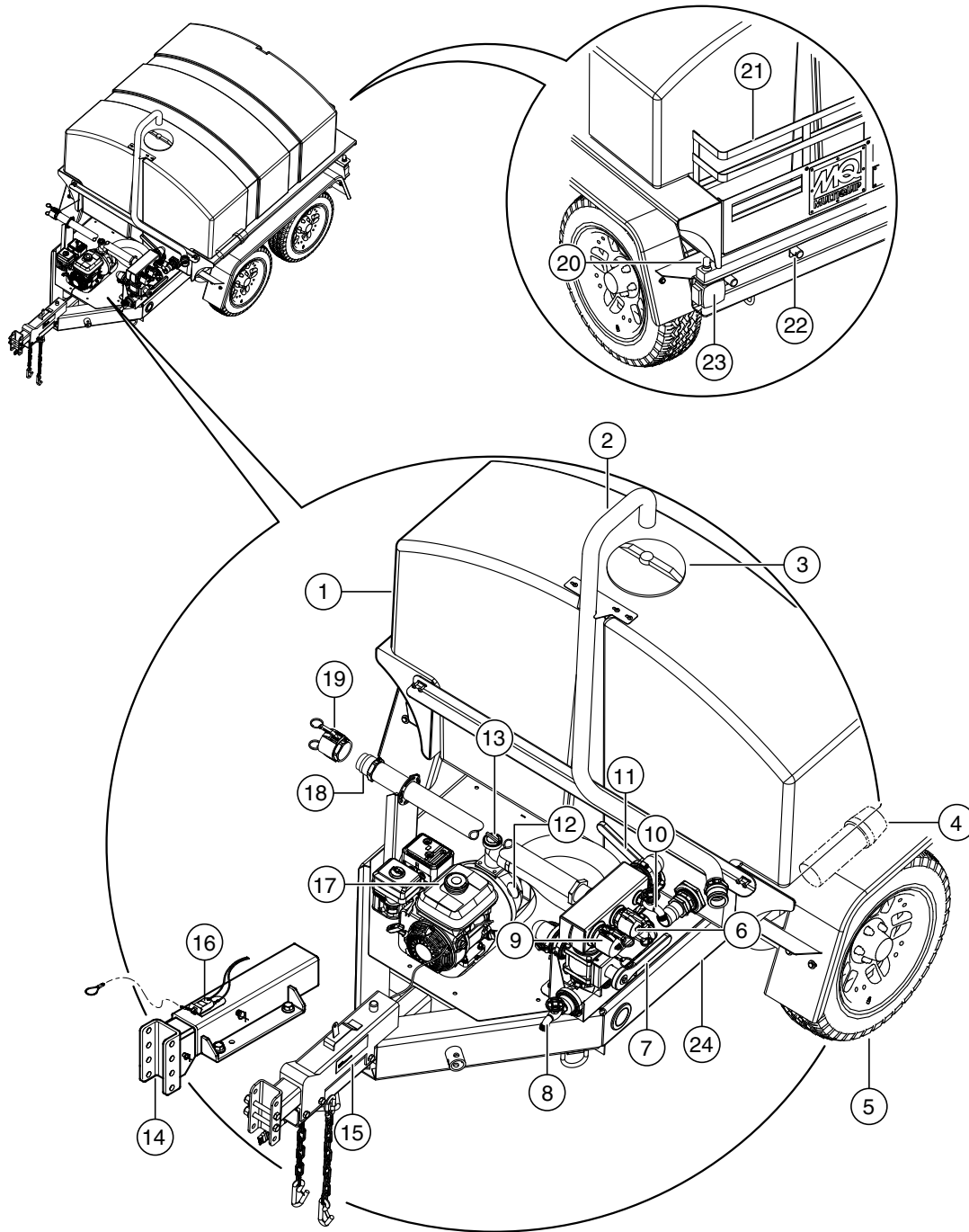

Figure 2. Water Trailer Components

## COMPONENTS (WATER TRAILER)

---

1. **Water Tank** — Capacity is 525 gallons (1,987 liters). Fill with clean water with no debris.
2. **Water Tank Fill Pipe** — 2" diameter steel pipe. Connect the 2" QD coupler end of this pipe to a fire hydrant. An interface hose will be required to connect from the pipe's QD coupler to the fire hydrant.
3. **Water Tank Cap** — Remove this cap (12-inch diameter fill port) to fill water tank if using a fire hydrant type method.
4. **Document Box** — Storage for documentation and other information regarding the water trailer.
5. **Tires** — This water trailer uses ST205/75D 14" size tires. Replace with only recommended type tires. Never tow water trailer with bad or worn tires.
6. **1.5" CAM and Groove Male QD Port** — This port can be used as either a suction or discharge port depending on the placement of the manifold control handle.
7. **Manifold Control Handle** — 3-position handle. Allows 3 different modes of operation, *off*, *discharge* or *suction*.
8. **Garden Hose Drain Valve** — When draining of the water tank is required open this valve to drain water.
9. **2.0" CAM and Groove Male QD Port** — This port (right-side) can be used as either a suction or discharge port depending on the placement of the manifold control handle.
10. **Garden Hose Valve** — When other options of filling of the water tank are unavailable, a garden hose can be connected to this valve to fill the water tank. It is recommended that a rigid walled garden hose or suction type garden hose be used for this purpose.  
  
In addition this valve can be used as a discharge port depending on the position of the manifold control lever. See Table 5.
11. **Spray Bar Control Handle** — 2-position handle, allows spray bar to be turned either *on* or *off*.
12. **Drain Plug** — Remove this plug to drain water from the pump.
13. **Fill Cap** — Prior to operation, the pump casing should be filled with water. Remove this cap to add water to the pump. After the initial prime, a sufficient amount of water will be retained in the casing so that the operator will not need to re-prime later.
14. **Coupler Adapters** — see Coupler Types section under Trailer Guidelines.
15. **Hydraulic Brake Actuator** — This actuator (Series WT5C only) will be activated in the event of a breakaway. The breakaway cable must be rigged to the tow vehicle with appropriate slack that will activate the system if the coupler connection comes loose.
16. **Electric Brake Actuator** — This actuator (Series WTE5C only) will be activated in the event of a breakaway. The breakaway cable must be rigged to the tow vehicle with appropriate slack that will activate the system if the coupler connection comes loose.
17. **Engine** — This water trailer uses a Honda GX120UT3PX2, 3.5 HP, air-cooled, 4-stroke, single-cylinder gasoline engine.
18. **2.0" CAM and Groove Male QD Port** — This port (left-side) can be used as either a suction or discharge port depending on the placement of the manifold control handle.
19. **Dust Cap** — There are 3 dust caps that are used with the manifold system. These caps prevent dirt and debris from entering the water system when the suction/discharge hoses are not connected.
20. **Spray Nozzles** — Located at the rear of the water trailer are two water spray nozzles. These nozzles can operate under multiple pressure settings.
21. **Storage Bin** — Place hoses and accessories in this bin during transport.
22. **License Light** — This light illuminates the license plate. Whenever towing of the light tower is required, make sure this light is operational.
23. **Brake Lights** — Before towing the water trailer, make sure that these lights are operational and are working correctly. Never tow the water trailer if these lights are inoperative.
24. **Low Point Drain Valve** — A standard garden hose bib located underneath manifold.

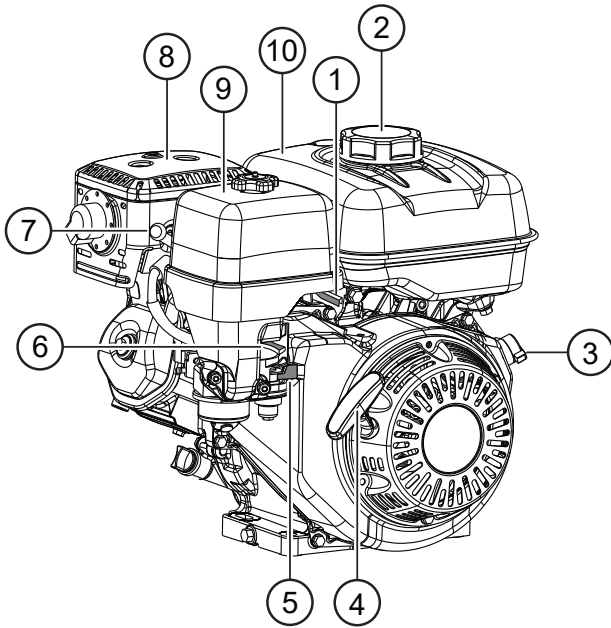

Figure 3. Engine Components

## INITIAL SERVICING

The engine (Figure 3) must be checked for proper lubrication and filled with fuel prior to operation. Refer to the engine manufacturer's manual for instructions and details of operation and servicing.

1. **Throttle Lever** — Used to adjust engine RPM speed (lever advanced forward SLOW, lever back toward operator FAST).
2. **Fuel Filler Cap** — Remove this cap to add unleaded gasoline to the fuel tank. Make sure cap is tightened securely. **DO NOT** over fill.

### DANGER



Adding fuel to the tank should be done only when the engine is stopped and has had an opportunity to cool down. In the event of a fuel spill, **DO NOT** attempt to start the engine until the fuel residue has been completely wiped up, and the area surrounding the engine is dry.

3. **Engine ON/OFF Switch** — ON position permits engine starting, OFF position stops engine operations.
4. **Recoil Starter (pull rope)** — Manual starting method. Pull the starter grip until resistance is felt, then pull briskly and smoothly.
5. **Fuel Valve Lever** — **OPEN** to let fuel flow, **CLOSE** to stop the flow of fuel.
6. **Choke Lever** — Used in the starting of a cold engine, or in cold weather conditions. The choke enriches the fuel mixture.
7. **Spark Plug** — Provides spark to the ignition system. Set spark plug gap to 0.6 – 0.7 mm (0.028 – 0.031 inch) Clean spark plug once a week.
8. **Muffler** — Used to reduce noise and emissions.

### WARNING



Engine components can generate extreme heat. To prevent burns, **DO NOT** touch these areas while the engine is running or immediately after operating. **NEVER** operate the engine with the muffler removed.

9. **Air Cleaner** — Prevents dirt and other debris from entering the fuel system. Remove wing-nut on top of air filter canister to gain access to filter element.

### NOTICE

Operating the engine without an air filter, with a damaged air filter, or a filter in need of replacement will allow dirt to enter the engine, causing rapid engine wear.

10. **Fuel Tank** — Holds unleaded gasoline. For additional information refer to engine owner's manual.



## ENGINE OIL CHECK

1. To check the engine oil level, place the unit on secure level ground with the engine stopped.
2. Remove the filler dipstick from the engine oil filler hole (Figure 4) and wipe it clean.

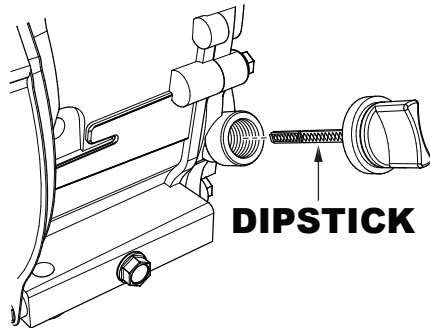
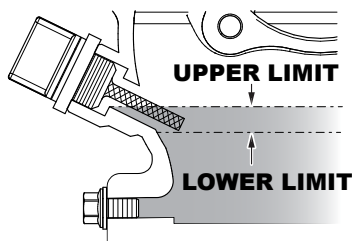

**Figure 4. Engine Oil Dipstick (Removal)**

3. Insert and remove the dipstick without screwing it into the filler neck. Check the oil level shown on the dipstick.
4. If the oil level is low (Figure 5), fill to the edge of the oil filler hole with the recommended oil type (Table 4). Maximum oil capacity is 0.63 quarts (0.6 liters).

### NOTICE

Refer to engine manufacturer's manual for specific servicing instructions.



**Figure 5. Engine Oil Dipstick (Oil Level)**

**Table 4. Oil Type**

Season	Temperature	Oil Type
Summer	25°C or Higher	SAE 10W-30
Spring/Fall	25°C ~ 10°C	SAE 10W-30/20
Winter	0°C or Lower	SAE 10W-10

## FUEL CHECK

### DANGER



Motor fuels are highly flammable and can be dangerous if mishandled. **DO NOT** smoke while refueling. **DO NOT** attempt to refuel if the engine is hot or running.

1. Remove the gasoline cap located on top of fuel tank.
2. Visually inspect to see if fuel level is low. If fuel is low, replenish with unleaded fuel.
3. When refueling, be sure to use a strainer for filtration. **DO NOT** top-off fuel. Wipe up any spilled fuel.

## STARTING THE ENGINE

1. Place the manifold control handle in the vertical position (OFF). See Table 5.
2. Place the engine fuel valve lever (Figure 6) to the **ON** position.

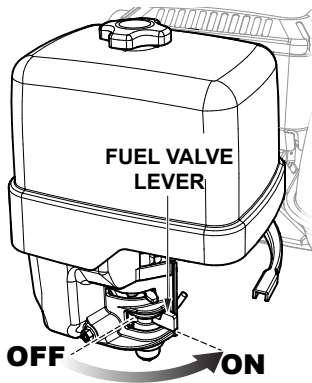

Figure 6. Engine Fuel Valve Lever (ON Position)

3. Move the throttle lever (Figure 7) away from the slow position, about 1/3 of the way toward the fast position.

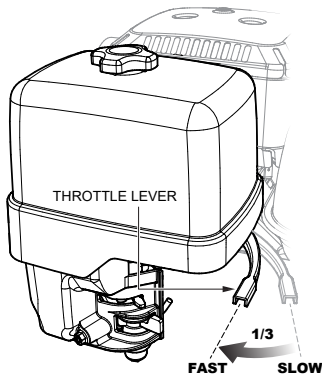

Figure 7. Throttle Lever (1/3 Start Position)

4. Place the choke lever (Figure 8) in the **CLOSED** position if starting a cold engine.

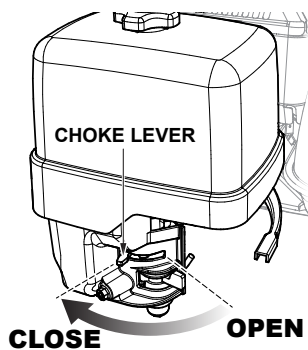

Figure 8. Engine Choke Lever (Closed)

5. Place the choke lever (Figure 9) in the **OPEN** position if starting a warm engine or the temperature is warm.

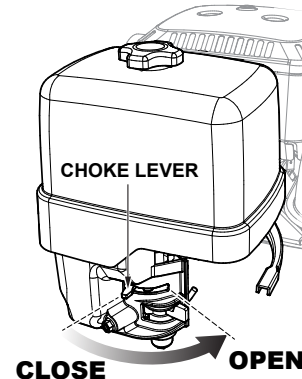

Figure 9. Engine Choke Lever (Open)

6. Place the engine **ON/OFF** switch (Figure 10) in the **ON** position.

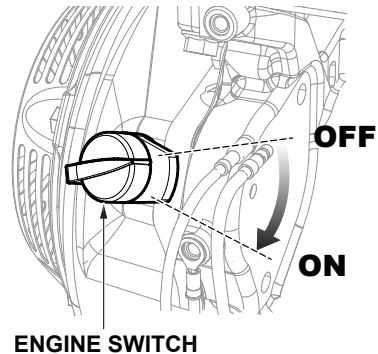

Figure 10. Engine ON/OFF Switch (ON Position)

7. Grasp the starter grip (Figure 11) and slowly pull it out. The resistance becomes the hardest at a certain position, corresponding to the compression point. Pull the starter grip briskly and smoothly for starting.

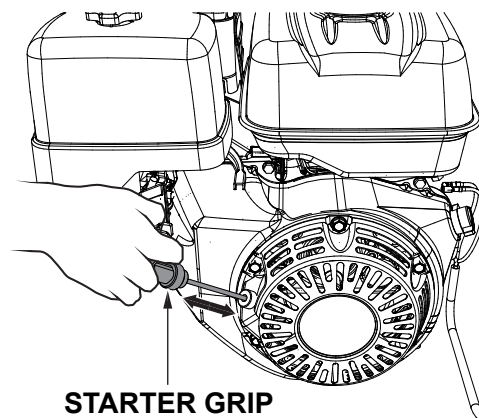
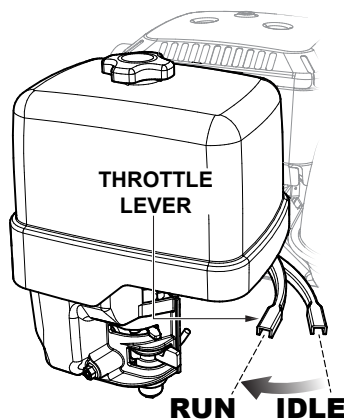

Figure 11. Starter Grip

- If the engine has started, and the choke lever was moved to the **CLOSED** position to start the engine, gradually move the choke lever to the **OPEN** position (Figure 9) as the engine warms up. If the engine has not started repeat steps 1 through 6.
- Before the water trailer is placed into operation, run the engine for several minutes.
- Check for fuel leaks and noises that would be associated with a loose component. Check for leaks between pump and engine. If water is leaking between the pump and engine housing, the seal inside the pump may be worn or damaged. Continued operation of the pump is not recommended. Further usage of the pump under these conditions may cause severe water damage to the engine.
- To begin pumping, place the throttle lever (Figure 12) in the **RUN** position.



**Figure 12. Throttle Lever (Run)**

- Set manifold and spray bar control handles as referenced in Table 5 to activate pumping.

## Stopping The Engine

### Normal Shutdown

- Move the throttle lever to the **IDLE** position (Figure 13) and run the engine for three minutes at low speed.

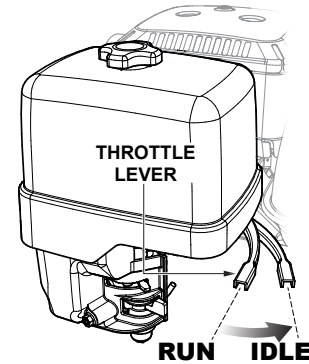

**Figure 13. Throttle Lever (Idle)**

- After the engine cools, turn the engine ON/OFF switch to the **OFF** position (Figure 14).

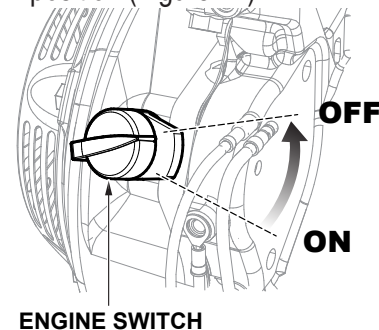

**Figure 14. Engine ON/OFF Switch (OFF Position)**

- Place the fuel shut-off lever (Figure 15) in the **OFF** position.

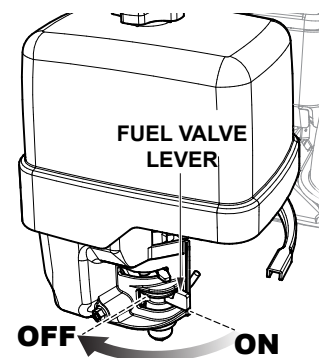
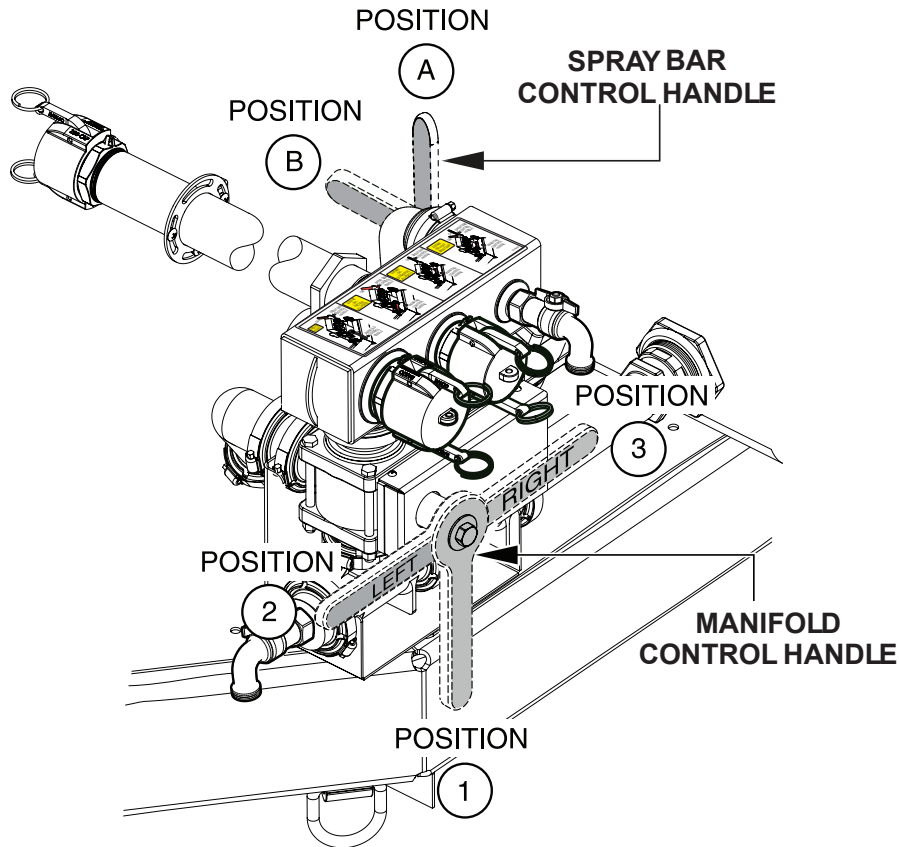

**Figure 15. Fuel Valve Lever (OFF)**

### Emergency Shutdown

Move the throttle lever quickly to the **IDLE** position, and place the engine ON/OFF switch in the **OFF** position.

Reference Figure 16 and Table 5 for the various control handle operating positions when using the Manifold and Spray Bar Control Handles.



**Figure 16. Pump Control Handles**

<b>Table 5. Pump Control Handle Operation</b>				
<b>Operational</b>	<b>Manifold Control Handle</b>	<b>Manifold Couplers</b>	<b>Spray Bar Control Handle</b>	<b>Rear Spray</b>
Engine Start/Parked	Position 1 (Vertical)	OFF	Position B (Horizontal)	OFF
Suction	Position 2 (Horizontal/Left)	ON	Position B (Horizontal)	OFF
Discharge	Position 3 (Horizontal/Right)	ON	Position B (Horizontal)	OFF
Discharge/Spray	Position 3 (Horizontal/Right)	ON	Position A (Vertical)	ON
Spray Only Dust Caps Attached To All 3 Ports	Position 3 (Horizontal/Right)	ON	Position A (Vertical)	ON

## OPERATION

There is an operating mode (Figure 17) that could be harmful to your water pump. Never operate the water trailer with the spray bar control handle in the vertical position (rear spray on), and the manifold control handle in the horizontal position (suction/left) with the engine running.

This mode of operation with no hoses attached causes the pump to draw in air creating unnecessary back pressure. Never operate the water trailer in this mode.

The recommended operating modes of the water trailer are shown in Table 5.

### NOTICE

**NEVER** operate the water trailer with the spray bar and manifold control handles as shown in Figure 17.

This mode of operation with the engine running causes the pump to draw in air, creating unnecessary back pressure.

### NOTICE

Prior to engine start, the pump **MUST BE** primed. This is accomplished by removing the Pump Fill Cap and filling the Pump Casing with water and then re-securing the fill cap.

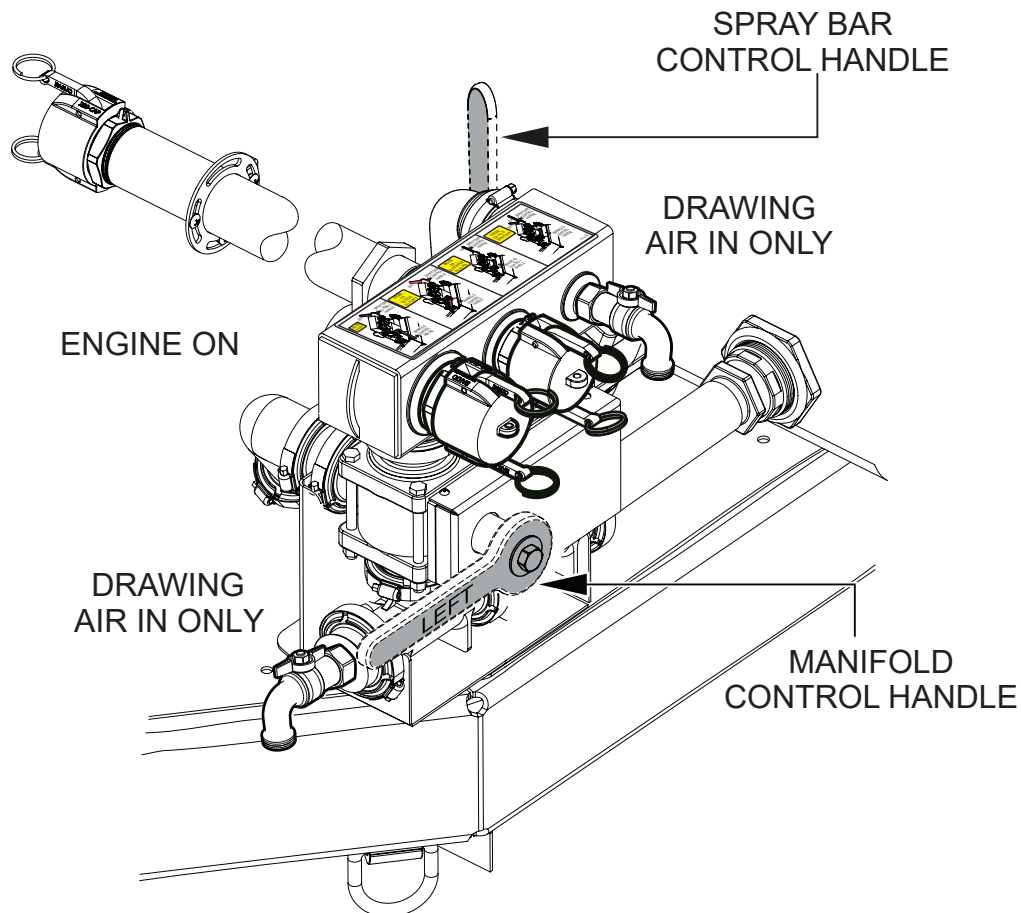

**Figure 17. Do Not Use Mode (Engine On)**

## FILLING THE WATER TANK (FIRE HYDRANT)

1. Remove the water tank cap.
2. Attach hydrant adapter to fire hydrant if necessary.
3. Attach fire hydrant discharge hose between the 2" steel water tank pipe QD port and the fire hydrant.
4. Make sure there are no bends or sharp kinks in the hose between the fire hydrant and water tank fill port.
5. Slowly open the hydrant valve. Water tank should begin to fill.
6. Fill the water tank to the desired level and close the fire hydrant valve.

7. Remove fire hydrant discharge hose and allow the hose to drain. Remove the hydrant adapter.

### NOTICE

**DO NOT** attempt to connect fire hydrant discharge to the suction side of the pump as a water source to fill the tank. The high psi discharge of the fire hydrant will damage the pump casing.

### NOTICE

Prior to engine start, the pump **MUST BE** primed. This is accomplished by removing the Pump Fill Cap and filling the Pump Casing with water and then re-securing the fill cap.

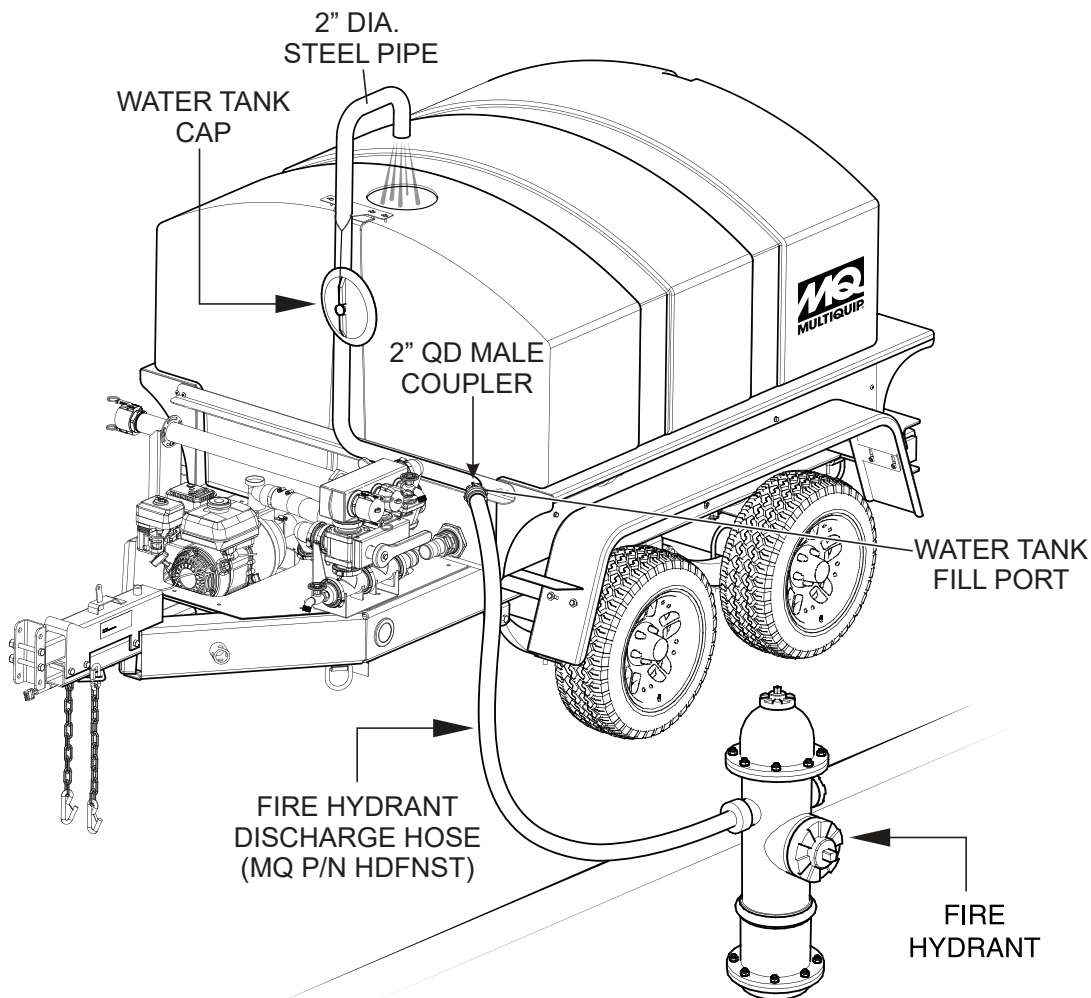

Figure 18. Fire Hydrant Connection

## FILLING THE WATER TANK (WATER SOURCE)

### 1.5 or 2.0" CAM and Groove Male QD Port

The following procedure shows how to fill the water tank using a swimming pool, pond, lake, river, etc. as a water source. Reference Figure 19.

1. Remove the dust cap from the desired CAM and groove male QD port from the upper manifold.
2. Connect suction hose between desired port (1.5" or 2.0") and water source.
3. Place spray bar and manifold control handles in the suction position as referenced in Table 5.
4. Fill the water tank to the desired level.
5. To stop water flow place manifold control handle in OFF position (vertical).

6. Remove suction hose.
7. Install dust cap back onto male QD port.

### Garden Hose

1. Connect garden hose between garden hose valve and water source.
2. Open garden hose valve.
3. Place spray bar and manifold control handles in suction position as referenced in Table 5.
4. Fill the water tank to the desired level.
5. To stop water flow place manifold control handle in OFF position (vertical).
6. Close garden hose valve.
7. Remove garden hose.

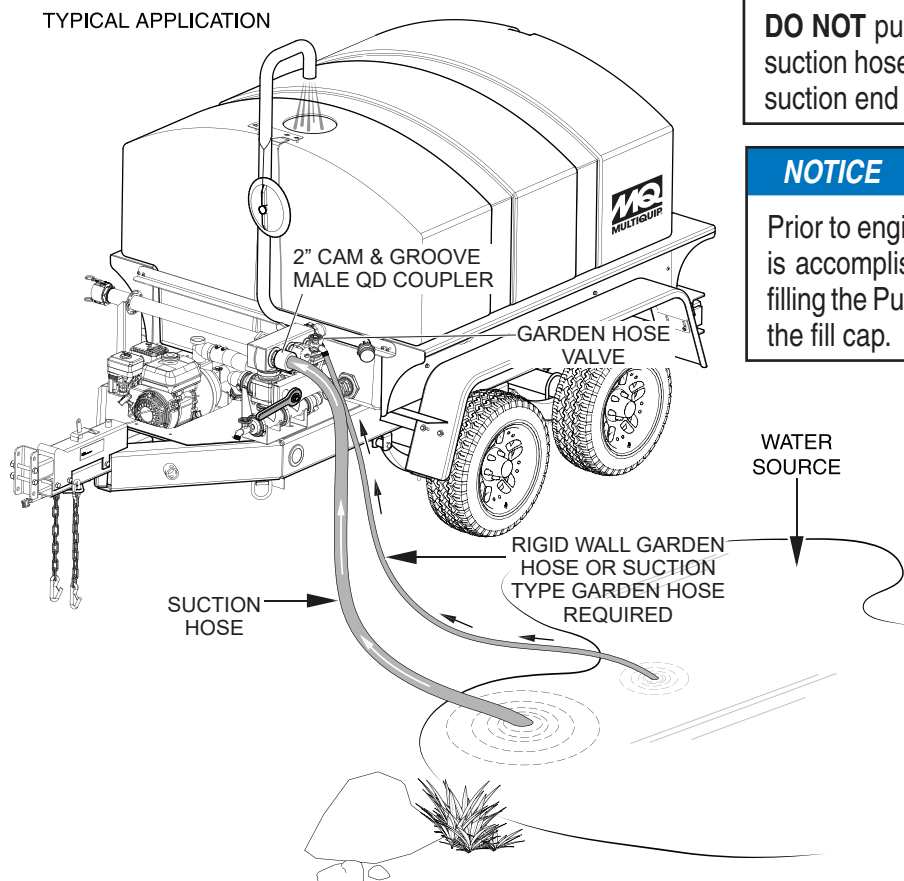

### NOTICE

**DO NOT** pump heavy debris-laden water. Ensure the suction hose is tethered in a manner that will keep the suction end off the bottom of ponds, lakes, rivers, etc.

### NOTICE

Prior to engine start, the pump **MUST BE** primed. This is accomplished by removing the Pump Fill Cap and filling the Pump Casing with water and then re-securing the fill cap.

Figure 19. Filling Water Tank (Water Source)

## DISCHARGING WATER

The following procedure shows how to discharge water from the water tank using the CAM and groove male QD couplers.

1. Remove dust cap from the desired CAM and groove male QD port from the upper manifold.
2. Place spray bar and manifold control handles in the discharge position as referenced in Table 5.

3. Figure 20 represents a typical water discharge application utilizing the rear spray bar.

### NOTICE

Prior to engine start, the pump **MUST BE** primed. This is accomplished by removing the Pump Fill Cap and filling the Pump Casing with water and then re-securing the fill cap.

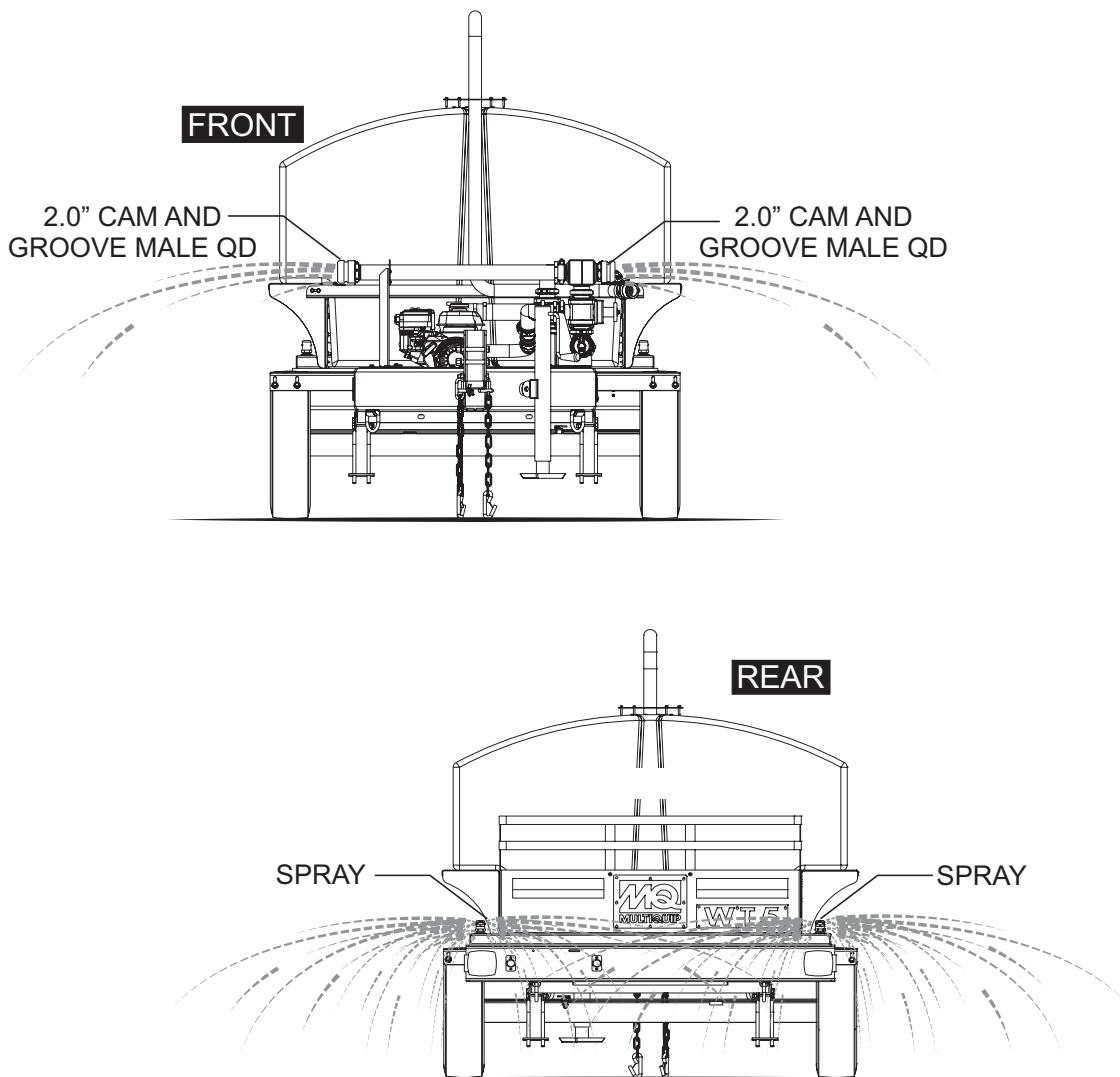

Figure 20. Discharging Water



# WINTERIZING PROCEDURE

## WINTERIZING

Perform the following procedure to protect water trailer from component damage in freezing temperature environments.

1. Make sure the water tank is completely empty. Use pump to remove any water present in the water tank.
2. Place unit on a level surface and raise trailer tongue by placing front jack stand to the highest position (Figure 21).

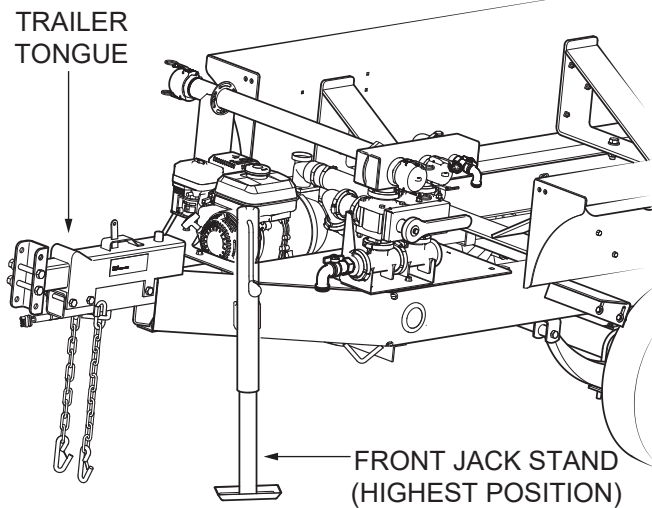

Figure 21. Raising Trailer Tongue

3. Locate and remove Pump Case Cover drain plug on pump end (Figure 22).

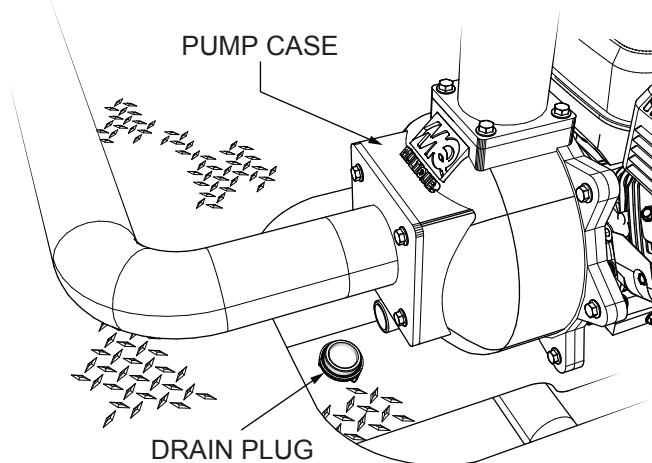

Figure 22. Removing Drain Plug

4. Rotate the manifold control handle to the 3 o'clock position (horizontal/right). See Figure 23.
5. Rotate the spray bar control handle to the 12 o'clock position (vertical). See Figure 23.

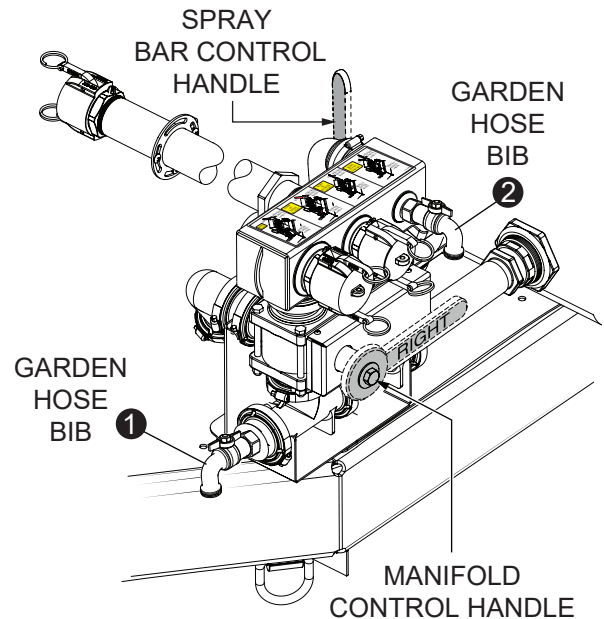

Figure 23. Control Handle Positions and Garden Hose Bibs Location

6. Locate and open all three garden hose bibs (parallel with pipe position) and leave open. See Figure 23 and Figure 24.

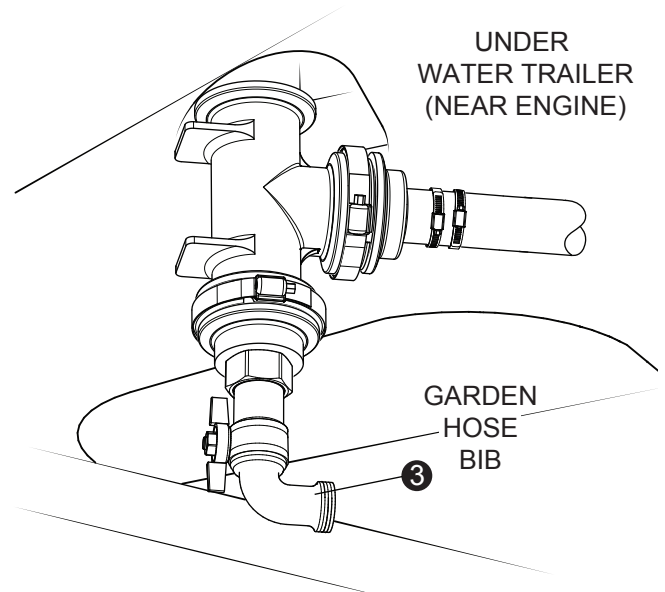

Figure 24. Third Garden Hose Bib Location

## WINTERIZING PROCEDURE

7. Once water appears to have all been drained, lower front trailer tongue by lowering front jack stand to the lowest position (Figure 25).

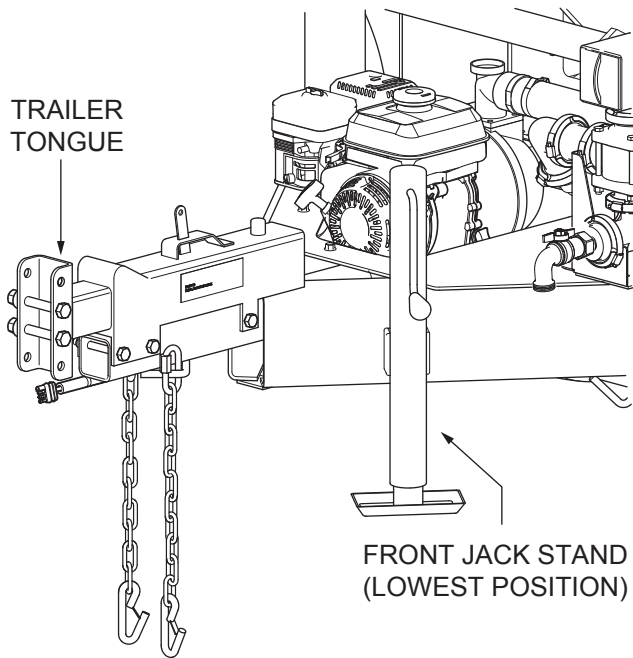

Figure 25. Lowering Trailer Tongue

8. Rotate the manifold control handle to the 9 o'clock position (horizontal/left) and leave it there (Figure 26).

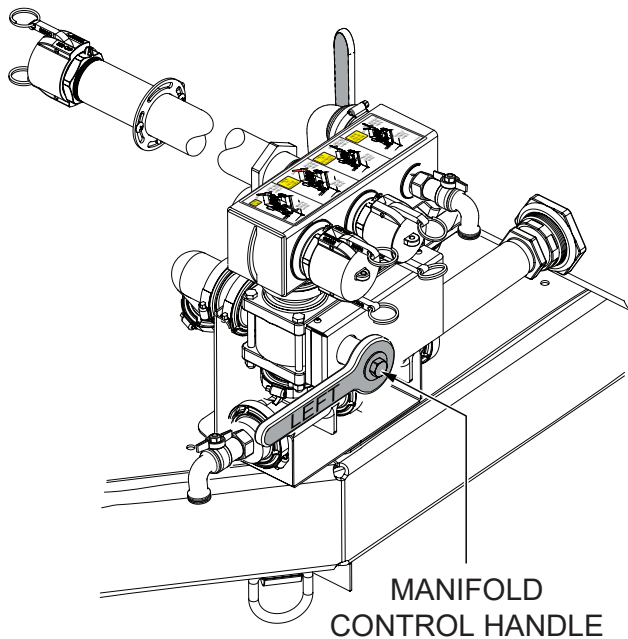

Figure 26. Manifold Control Handle Position

9. Once fluid has stopped draining, reinstall the drain plug on pump end.

### NOTICE

It is important to cycle the manifold control handle from the 3 o'clock position then back to 9 o'clock position to allow all water to drain from the entire manifold valve assembly.

**NEVER** leave the manifold control handle in the 12 o'clock or 6 o'clock position.

**ALWAYS** leave the spray bar control handle in the 12 o'clock position.

## PUMP VACUUM TEST

### **CAUTION**

**DO NOT** attempt to start the engine unless the pump has previously been primed with water. Severe pump damage will occur if pump has not been primed.

To perform the pump vacuum test do the following:

1. Remove the pump fill cap and fill the pump with water.
2. Start the engine as outlined in the operation section, and wait for the pump to begin pumping.
3. As shown in Figure 27, place a water hose inside the discharge opening of the pump, and turn on the water. This flow of water into the discharge opening will prevent the pump from running dry.
4. Place the Pump Vacuum Tester (P/N 7000030) over the pump suction (inlet) opening with the vacuum gauge facing upwards. It may be necessary to apply a small amount of water around the rubber seal of the vacuum tester to make a good suction fit.
5. Check and make sure that there are no air leaks between the vacuum tester and the inlet port on the pump. If air leaks are present reset vacuum tester.
6. Run the pump for a few minutes while monitoring the vacuum gauge. If the gauge indicates a reading between -25 and -20 in. Hg. (inches of mercury) then it can be assumed that the pump is working correctly.
7. If the vacuum tester gauge indicates a reading below -20 in. Hg, it can then be assumed that the pump is not functioning correctly, and corrective action needs to be taken.

### **NOTICE**

25 in. Hg (inches of mercury) translates into 25 feet of lift at sea level.

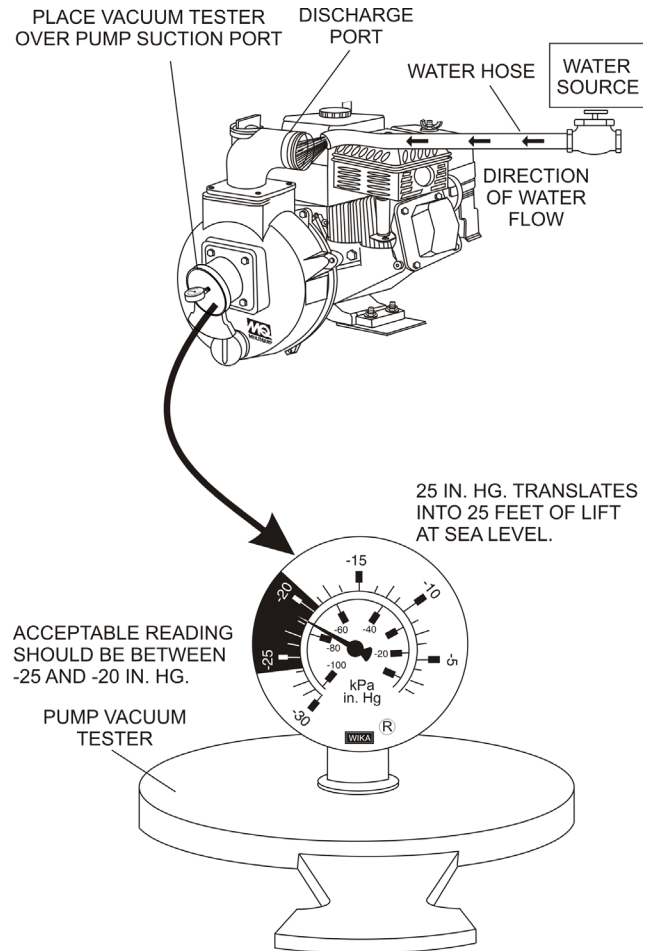

**Figure 27. Pump Vacuum Test**

### **NOTICE**

Vacuum test may be performed without water flowing through the discharge port. However, it is recommended to have water flowing to prevent any heat-up.

# MAINTENANCE

Use Table 6 as a general maintenance guideline when servicing your engine. For more detailed engine maintenance information, refer to the engine owner's manual supplied with your engine.

**Table 6. Engine Maintenance Schedule**

DESCRIPTION (3)	OPERATION	BEFORE	FIRST MONTH OR 10 HRS.	EVERY 3 MONTHS OR 25 HRS.	EVERY 6 MONTHS OR 50 HRS.	EVERY YEAR OR 100 HRS.	EVERY 2 YEARS OR 200 HRS.
Engine Oil	Check	X					
	Change		X				
Air Cleaner	Check	X					
	Change			X (1)			
All Nuts and Bolts	Re-tighten if necessary	X					
Spark Plugs	Check/Clean				X		
	Replace						X
Cooling Fins	Check				X		
Spark Arrester	Clean					X	
Fuel Tank	Clean					X	
Fuel Filter	Check					X	
Idle Speed	Check/ Adjust					X (2)	
Valve Clearance	Check/ Adjust						X (2)
Fuel Lines	Check	Every 2 years (replace if necessary) (2)					

(1) Service more frequently when used in **DUSTY** areas.

(2) These items should be serviced by your service dealer, unless you have the proper tools and are mechanically proficient. Refer to the HONDA Shop Manual for service procedures.

(3) For commercial use, log hours of operation to determine proper maintenance intervals.

Perform the scheduled maintenance procedures as defined by Table 6 and below:

## DAILY

- Thoroughly remove dirt and oil from the engine and control area. Clean or replace the air cleaner elements as necessary. Check and retighten all fasteners as necessary. Check the gearbox for oil leaks. Repair or replace as needed.

## WEEKLY

- Remove the fuel filter cap and clean the inside of the fuel tank.
- Remove or clean the filter at the bottom of the tank.
- Remove and clean the spark plug (Figure 28), then adjust the spark gap to 0.024–0.028 inch (0.6–0.7 mm). This unit has electronic ignition, which requires no adjustments.

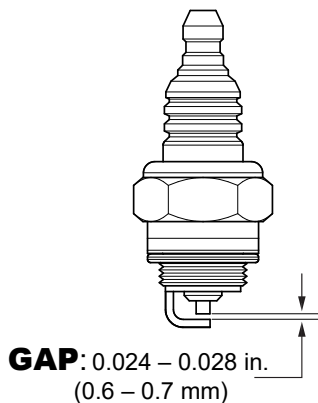

**Figure 28. Spark Plug Gap**

## ENGINE OIL

- Drain the engine oil when the oil is warm as shown in Figure 29.
- Remove the oil drain bolt and sealing washer and allow the oil to drain into a suitable container.
- Replace engine oil with recommended type oil as listed in Table 4. For engine oil capacity, see Table 1 (Specifications). **DO NOT** overfill.
- Install drain bolt with sealing washer and tighten securely.

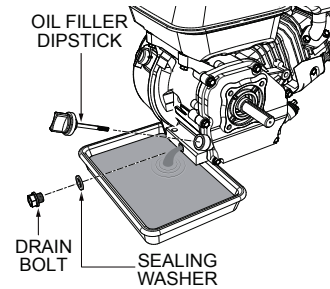

**Figure 29. Engine Oil (Draining)**

## ENGINE AIR CLEANER

- Remove the air cleaner cover and foam filter element as shown in Figure 30.
- Tap the paper filter element (Figure 30) several times on a hard surface to remove dirt, or blow compressed air not exceeding 30 psi (207 kPa, 2.1 kgf/cm<sup>2</sup>) through the filter element from the air cleaner case side. **NEVER** brush off dirt. Brushing will force dirt into the fibers. Replace the paper filter element if it is excessively dirty.
- Clean foam element in warm, soapy water or nonflammable solvent. Rinse and dry thoroughly. Dip the element in clean engine oil and completely squeeze out the excess oil from the element before installing.

### **! DANGER**

**DO NOT** use gasoline as a cleaning solvent to avoid creating the risk of fire or an explosion.

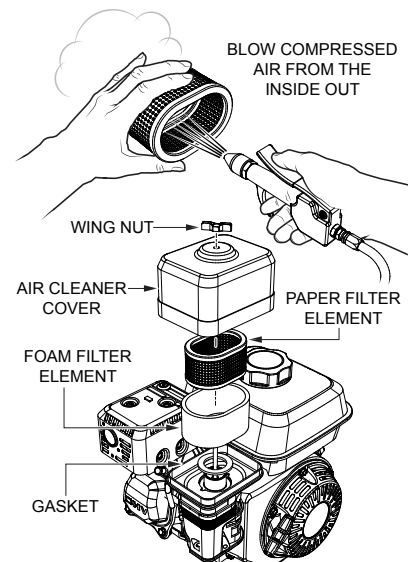

**Figure 30. Engine Air Cleaner**

## STORAGE

For storage of the unit for over 30 days, the following is required:

- Drain the fuel tank completely.
- Run the engine until the fuel in the carburetor is completely consumed.
- Completely drain used oil from the engine crankcase and fill with fresh clean oil, then follow the procedure described in the engine manual for engine storage.
- Remove the drain plug from the pump and drain out any water left in the housing.
- Remove the pump cover and clean inside of pump housing. Coat inside of pump housing with a light film of oil to reduce corrosion. A spray can of oil works well for this application.
- Cover pump and engine with plastic covering or equivalent and store in a clean, dry place.
- To protect the water-cooled seals, place one-half pint of lubricating oil (new or used) through the discharge opening on the pump and crank the engine several times. This will prevent excessive corrosion and also keep the mechanical seal lubricated.
- Drain water tank completely.

The following trailer maintenance guidelines are intended to assist the operator in preventive maintenance.

## TRAILER BRAKES

Properly functioning brake shoes and drums are essential to ensure safety. The brakes should be inspected the first 200 miles of operation. This will allow the brake shoes and drums to seat properly. After the first 200-mile interval, inspect the brakes every 3,000 miles. If driving over rough terrain, inspect the brakes more frequently.

## HYDRAULIC BRAKES

If your trailer has hydraulic brakes, they function the same way the surge brakes do on your tow vehicle. The hydraulic braking system must be inspected at least as often as the brakes on the tow vehicle, but no less than once per year. This inspection includes an assessment of the condition and proper operation of the wheel cylinders, brake shoes, brake drums and hubs.

## MANUALLY ADJUSTING THE BRAKES

Most axles are fitted with a brake mechanism that will adjust the brakes during a hard stop. However, some braking systems are not automatically adjusted by hard stopping. These brakes require manual adjustment. The following steps apply to adjust most manually adjustable brakes.

1. Jack up the trailer and secure it on adequate capacity jack stands.
2. Be sure the wheel and brake drum rotate freely.
3. Remove the adjusting-hole cover from the adjusting slot on the bottom of the brake backing plate.
4. With a screwdriver or standard adjusting tool, rotate the starwheel of the adjuster assembly to expand the brake shoes. Adjust the brake shoes out until the pressure of the linings against the drum makes the wheel very difficult to turn. Note: Your trailer may be equipped with drop spindle axles. See axle manual for your axle type. You will need a modified adjusting tool for adjusting the brakes in these axles. With drop spindle axles, a modified adjusting tool with about an 80-degree angle should be used.
5. Rotate the starwheel in the opposite direction until the wheel turns freely with a slight drag.

6. Replace the adjusting-hole cover.
7. Repeat the above procedure on all brakes.
8. Lower the trailer to the ground.

Check the fluid level in the master cylinder reservoir at least every three months. If you tow your trailer an average of 1,000 miles per month in a hot and dry environment, you must check the brake fluid level once a month. The brake fluid reservoir is located on the tongue of the trailer. Always fill with clean, uncontaminated DOT 4 brake fluid.

Figure 31 below displays the major hydraulic brake components that will require inspection and maintenance. Please inspect these components as required using steps 1 through 6 as referenced in the “Manually Adjusting The Brakes” section on this page. See Table 7 for Hydraulic Brake Troubleshooting.

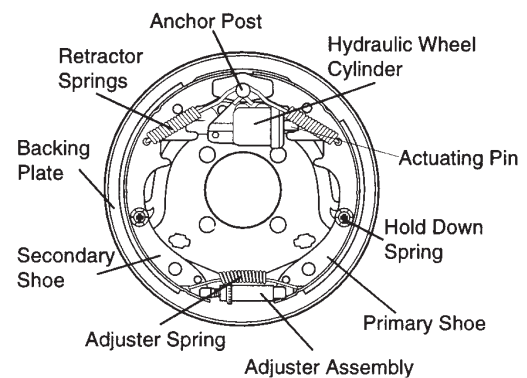

**Figure 31. Hydraulic Brake Components**

## HYDRAULIC BRAKE ACTUATOR

The hydraulic brake actuator (Figure 32) is the mechanism that activates the trailer's brake system. This actuator changes fluid power into mechanical power. Therefore, the fluid level must be checked frequently to ensure that the brakes function properly.

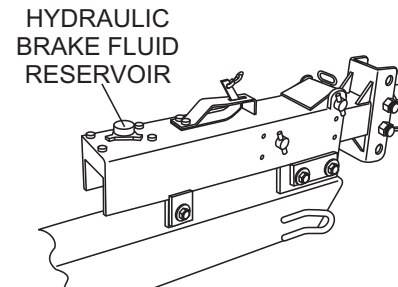

**Figure 32. Hydraulic Brake Actuator**

## ⚠ WARNING

Failure to maintain proper fluid level in the actuator may result in loss of braking action which could cause severe property damage, injury or death.

Periodically check the actuator mounting fasteners for damage or loosening. Inspect the actuator for worn or damaged parts. As you are towing your trailer, be aware of any changes in braking quality. This could be an early warning of brake or actuator malfunction and requires immediate attention. Consult a certified brake specialist to make necessary adjustment or repairs.

**Table 7. Hydraulic Brake Troubleshooting**

Symptom	Possible Cause	Solution
No Brakes	Brake line broken or kinked?	Repair or replace.
Weak Brakes or Brakes Pull to One Side	Brake lining glazed?	Reburnish or replace.
	Trailer overloaded?	Correct weight.
	Brake drums scored or grooved?	Machine or replace.
	Tire pressure correct?	Inflate all tires equally.
	Tires unmatched on the same axle?	Match tires.
Locking Brakes	Brake components loose, bent or broken?	Replace components.
	Brake drums out-of-round?	Replace.
Noisy Brakes	System lubricated?	Lubricate.
	Brake components correct?	Replace and correct.
Dragging Brakes	Brake lining thickness incorrect or not adjusted correctly?	Install new shoes and linings.
	Enough brake fluid or correct fluid?	Replace rubber parts fill with dot 4 fluid.

## ELECTRIC BRAKES

Electrically actuated brakes (Figure 33) are similar to hydraulic brakes. The basic difference is that electric brakes are actuated by an electromagnet. Listed below are some of the advantages that electric brakes have over hydraulic brakes:

- Brake system can be manually adjusted to provide the corrected braking capability for varying road and load conditions.
- Brake system can be modulated to provide more or less braking force, thus easing the brake load on the towing vehicle.

- Brake system has very little lag time between the time the vehicle's brakes are actuated and the trailer's brakes are actuated.
- Brake system can provide an independent emergency brake system.
- The model WTE5C (electric brake) comes standard with a 6-pin connector for tow vehicle electrical hook-up. If a 7-pin connector is required, order with Part No. EE55622.

Remember in order to properly synchronize the tow vehicle's braking to the trailer's braking, can only be accomplished by road testing. Brake lockup, grabbiness or harshness is due to lack of synchronization between the tow vehicle and the trailer being towed or under-adjusted brakes.

Before any brake synchronization adjustments can be made, the trailer brakes should be burnished-in by applying the brakes 20–30 times with approximately a 20 mph decrease in speed, e.g. 40 mph to 20 mph. Allow ample time for brakes to cool between application. This allows the brake shoes to slightly be seated into the brake drum surface.

Figure 33 displays the major electric brake components that will require inspection and maintenance. Please inspect these components as required. See Table 8.

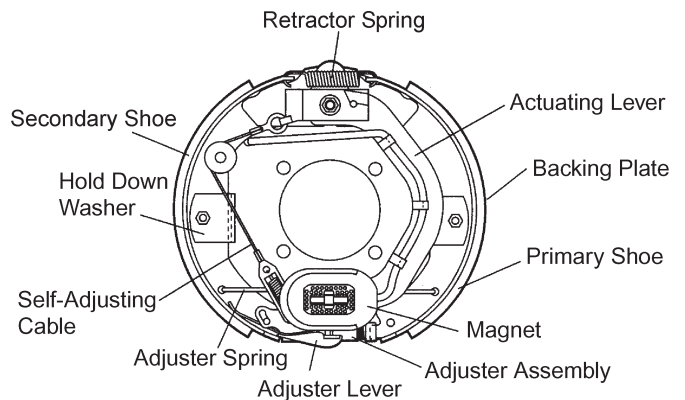
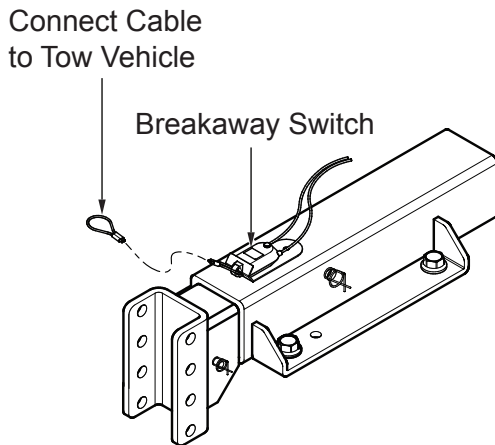

**Figure 33. Electrical Brake Components**



## ELECTRIC BRAKE ACTUATOR

The electric brake actuator (Figure 34) is the mechanism that activates the trailer's brake system. For electric brake equipped trailers, the breakaway brake system includes a DC power source, a switch with a pull pin, and a breakaway brake controller. Read and follow the instructions that have been prepared by the breakaway brake controller manufacturer.



**Figure 34. Electric Brake Actuator**

## Electrically Operated Hydraulic Brakes

Electric/hydraulic braking systems which are mounted on the trailer, use a small electrically driven pump to generate hydraulic pressure, which operates the brake cylinders. Like electrical brakes, an electric/hydraulic braking system is operated by an electrical signal from the tow vehicle.

## BREAKAWAY BRAKE

### Breakaway Battery

This battery supplies the power to operate the trailer brakes if the trailer uncouples from the tow vehicle. Be sure to check, maintain and replace the battery according to the battery manufacturer's instructions.

### Breakaway Switch

This switch causes the breakaway battery to operate the electric brakes if the trailer uncouples from the tow vehicle. The pull cable for the pull pin is connected to the tow vehicle, and the switch is connected to the trailer.

To check for proper functioning of the switch, battery and brakes, you must pull the pin from the switch and confirm

that the brakes apply to each wheel. You can do this by trying to pull the trailer with the tow vehicle, after pulling the pin. The trailer brakes may not lock, but you will notice that a greater force is needed to pull the trailer.

### **WARNING**

If electric breakaway brakes do not operate when trailer is uncoupled from the tow vehicle, death or serious injury can occur. Check emergency breakaway brake system **BEFORE** each tow.

## Tow Vehicle Operated Electric Brakes

The electric brakes that operate in conjunction with the tow vehicle brakes must be "synchronized" so that braking is properly distributed to the tow vehicle brakes and the trailer brakes. For proper operation and synchronization, read and follow the axle/brake and the brake controller manufacturer's instructions.

To make certain an electrically operated braking system will function properly, you must have your dealer inspect the magnets at least once a year, or each 12,000 miles. See the brake manual for wear and current inspection instructions.

**Table 8. Electric Brake Troubleshooting**

Symptom	Possible Cause	Solution
No Brakes or Intermittent Brakes	Any open circuits or broken wires?	Find and correct.
	Any short circuits?	Find and correct.
	Faulty controller?	Test and correct.
	Any loose connections?	Find and repair.
	Ground wire secure?	Find and secure.
Weak Brakes or Brakes Pull to One Side	Grease or oil on magnets or linings?	Clean or replace.
	Connections corroded?	Clean and correct cause of corrosion.
	Brake drums scored or grooved?	Machine or replace.
	Brakes synchronized?	Correct.
Locking Brakes	Brake components loose, bent or broken?	Replace components.
	Brake drums out-of-round?	Replace.
Noisy Brakes	System lubricated?	Lubricate.
	Brake components correct?	Replace and correct.
Dragging Brakes	Brake lining thickness incorrect or not adjusted correctly?	Install new shoes and linings.
	Enough brake fluid or correct fluid?	Replace rubber parts fill with dot 4 fluid.

## ADJUSTABLE CHANNEL

Your trailer may be equipped with an adjustable channel (Figure 35) that allows the coupler to be raised or lowered to a desired height. Periodically check the channel bolts for damage or loosening.

### NOTICE

When replacing channel mounting hardware (nuts, bolts and washers), **NEVER** substitute substandard hardware. Pay close attention to **bolt length** and **grade**. **ALWAYS** use manufacturer's recommended parts when replacing channel mounting hardware.

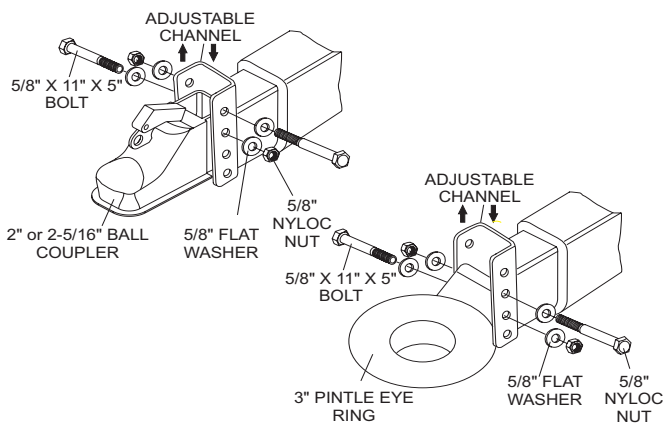

**Figure 35. Adjustable Channel**

## WHEEL BEARINGS

Wheel bearings (Figure 36) must be inspected and lubricated once a year or every 12,000 miles to ensure safe operation of your trailer.

If trailer wheel bearings are immersed in water, they must be replaced.

### **!** DANGER

If trailer wheels are underwater for a long period of time, wheel bearings may fail. If this is the case, service wheel bearings immediately.

The possibility exists of the wheels falling off causing equipment damage and severe bodily harm even death!

If the trailer has not been used for an extended amount of time, have the bearings inspected and packed more frequently, at least every six months and prior to use.

Follow the steps below to disassemble the wheel hub and service the wheel bearings. See Figure 36.

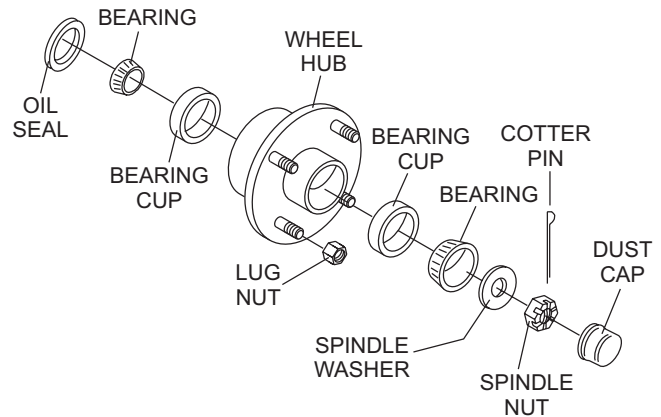

**Figure 36. Wheel Hub Components**

- After removing the dust cap, cotter pin, spindle nut and spindle washer, remove the hub to inspect the bearings for wear and damage.
- Replace bearings that have flat spots on rollers, broken roller cages, rust or pitting. Always replace bearings and cups in sets. The inner and outer bearings are to be replaced at the same time.
- Replace seals that have nicks, tears or wear.
- Lubricate the bearings with a high-quality EP-2 automotive wheel bearing grease.

## WHEEL HUB ADJUSTMENT

Every time the wheel hub is removed and the bearings are reassembled, follow the steps below to check the wheel bearings for free running and adjust.

- Turn the hub slowly, by hand, while tightening the spindle nut until you can no longer turn the hub by hand.
- Loosen the spindle nut just until you are able to turn it (the spindle nut) by hand. Do not turn the hub while the spindle nut is loose.
- Install a new cotter pin through the spindle nut and axle.
- Check the adjustments. Both the hub and the spindle nut should be able to move freely (the spindle nut motion will be limited by the cotter pin).

### **! DANGER**

**NEVER** crawl under the trailer unless it is on firm and level ground and resting on properly placed and secured jackstands.

The possibility exists of the trailer falling thus causing equipment damage and severe bodily harm even death!

### **! DANGER**

When performing trailer inspection and maintenance activities, you must jack up the trailer using jacks and jackstands.

When jacking and using jackstands, place them so as to clear wiring, brake lines, and suspension parts (i.e. springs, torsion bars). Place jacks and jackstands inside of the perimeter strip on the supporting structure to which the axles are attached.

### **! DANGER**

Improper weld repair will lead to early failure of the trailer structure and can cause serious injury or death.

**DO NOT** repair cracked or broken welds unless you have a certified welder perform the repair. If not, have the welds repaired by your dealer.

### **! WARNING**

If the trailer is involved in an accident, have it inspected immediately by qualified personnel. In addition, the trailer should be inspected annually for signs of wear or deformations.

## LEAF SUSPENSION

The leaf suspension springs and associated components (Figure 37) should be visually inspected every 6,000 miles for signs of excessive wear, elongation of bolt holes, and loosening of fasteners. Replace all damaged parts (suspension) immediately.

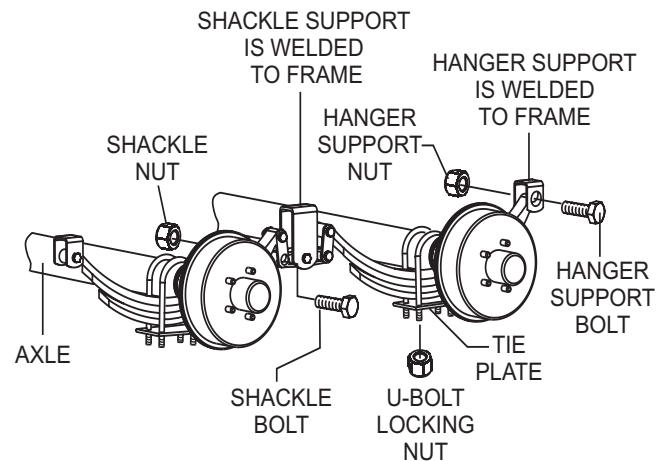

**Figure 37. Leaf Suspension Components**

### **! DANGER**

Worn or broken suspension parts can cause loss of control, damage to equipment and severe bodily injury, even death!

Check suspension regularly.

# TRAILER SAFETY GUIDELINES

---

The following guidelines are intended to assist the operator in the operation and handling of a trailer.

Safety precautions should be followed at all times when operating a trailer. Failure to read, understand and follow the safety guidelines could result in injury to yourself and others. Loss of control of the trailer or tow vehicle can result in death or serious injury.

## COMMON CAUSES FOR LOSS OF TRAILER

- Driving too fast for the conditions (maximum speed when towing a trailer is 55 mph).
- Overloading the trailer or loading the trailer unevenly.
- Trailer improperly coupled to the hitch.
- No braking on trailer.
- Not maintaining proper tire pressure.
- Not keeping lug nuts tight.
- Not properly maintaining the trailer structure.
- Ensure machine is towed level to tow vehicle.

## TRAILER TOWING GUIDELINES

- Recheck the load tiedowns to make sure the load will not shift during towing.
- Before towing, check coupling, safety chain, safety brake, tires, wheels and lights.
- Check the lug nuts or bolts for tightness.
- Check coupler tightness after towing 50 miles.
- Use your mirrors to verify that you have room to change lanes or pull into traffic.
- Use your turn signals well in advance. Allow plenty of stopping space for your trailer and tow vehicle.
- Allow plenty of stopping space for your trailer and tow vehicle.
- **DO NOT** drive so fast that the trailer begins to sway due to speed.
- Allow plenty of room for passing. A rule of thumb is that the passing distance with a trailer is 4 times the passing distance without the trailer.

- Shift your automatic transmission into a lower gear for city driving.
- **ALWAYS** use lower gears for climbing and descending grades.
- **DO NOT** ride the brakes while descending grades, they may get so hot that they stop working. Then you will potentially have a runaway tow vehicle and trailer.
- To conserve fuel, don't use full throttle to climb a hill. Instead, build speed on the approach.
- Slow down for bumps in the road. Take your foot off the brake when crossing the bump.
- **DO NOT** brake while in a curve unless absolutely necessary. Instead, slow down before you enter the curve and power through the curve. This way, the towing vehicle remains in charge.
- **DO NOT** apply the brakes to correct extreme trailer swaying. Continued pulling of the trailer, and even slight acceleration, will provide a stabilizing force.
- Anticipate the trailer "swaying." Swaying is the trailer reaction to the air pressure wave caused by passing trucks and buses. Continued pulling of the trailer provides a stabilizing force to correct swaying. **DO NOT** apply the brakes to correct trailer swaying.
- Use lower gear when driving down steep or long grades. Use the engine and transmission as a brake. Do not ride the brakes, as they can overheat and become ineffective.
- Be aware of your trailer height, especially when approaching roofed areas and around trees.
- Make regular stops, about once each hour. Confirm that:
  - Coupler is secure to the hitch and is locked.
  - Electrical connectors are secure.
  - There is appropriate slack in the safety chains.
  - There is appropriate slack in the breakaway switch pullpin cable.
  - Tires are not visibly low on pressure.

# TRAILER SAFETY GUIDELINES

## DRIVING CONDITIONS

When towing a trailer, you will have decreased acceleration, increased stopping distance, and increased turning radius (which means you must make wider turns to keep from hitting curbs, vehicles, and anything else that is on the inside corner). In addition, you will need a longer distance to pass, due to slower acceleration and increased length.

- Be alert for slippery conditions. You are more likely to be affected by slippery road surfaces when driving a tow vehicle with a trailer, than driving a tow vehicle without a trailer.
- Check rearview mirrors frequently to observe the trailer and traffic.
- **NEVER** drive faster than what is safe.

### **WARNING**

Driving too fast for severe road conditions can result in loss of control and cause death or serious injury.

Decrease your speed as road, weather, and lighting conditions deteriorate.

Always check for local trailer tow speed limits in your area.

### **WARNING**

Do not transport people on the trailer. The transport of people puts their lives at risk and may be illegal.

## COUPLING TO THE TOW VEHICLE

Follow all of the safety precautions and instructions in this manual to ensure safety of persons, equipment, and satisfactory life of the trailer. Always use an adequate tow vehicle and hitch. If the vehicle or hitch is not properly selected and matched to the Gross Vehicle Weight Rating (GVWR) of your trailer, you can cause an accident that could lead to death or serious injury.

If you already have a tow vehicle, know your vehicle tow rating and make certain the trailer's rated capacity is less than or equal to the tow vehicle's rated towing capacity. If you already have (or plan to buy) a trailer, make certain that the tow rating of the tow vehicle is equal to or greater than that of the trailer.

The trailer VIN tag contains the critical safety information

for the use of your trailer. Again, be sure your hitch and tow vehicle are rated for the Gross Vehicle Weight Rating of your trailer.

### **WARNING**

Proper selection and condition of the coupler and hitch are essential to safely towing your trailer. A loss of coupling may result in death or serious injury.

- Be sure the hitch load rating is equal to or greater than the load rating of the coupler.
- Be sure the hitch size matches the coupler size.
- Observe the hitch for wear, corrosion and cracks before coupling. Replace worn, corroded or cracked hitch components before coupling the trailer to the tow vehicle.
- Be sure the hitch components are tight before coupling the trailer to the tow vehicle.

### **WARNING**

An improperly coupled trailer can result in death or serious injury.

**DO NOT** move the trailer until:

- The coupler is secured and locked to hitch.
- The safety chains are secured to the tow vehicle.
- The trailer jack(s) are fully retracted.

**DO NOT** tow the trailer on the road until:

- Tires and wheels are checked.
- The trailer brakes are checked.
- The breakaway switch is connected to the tow vehicle.
- The load is secured to the trailer.
- The trailer lights are connected and checked.

### **WARNING**

Use of a hitch with a load rating less than the load rating of the trailer can result in loss of control and may lead to death or serious injury.

Use of a tow vehicle with a towing capacity less than the load rating of the trailer can result in loss of control, and may lead to death or serious injury.

Be sure your hitch and tow vehicle are rated for the Gross Vehicle Weight Rating of your trailer.

# TRAILER SAFETY GUIDELINES

## INOPERABLE BRAKES, LIGHTS OR MIRRORS

Be sure that the brakes and all of the lights on your trailer are functioning properly before towing your trailer. Check the trailer taillights by turning on your tow vehicle headlights. Check the trailer brake lights by having someone step on the tow vehicle brake pedal while you look at the trailer lights. Do the same thing to check the turn signal lights. See Trailer Wiring Diagram section in this manual.

Standard mirrors usually do not provide adequate visibility for viewing traffic to the sides and rear of a towed trailer. You must provide mirrors that allow you to safely observe approaching traffic.

### WARNING

Improper electrical connection between the tow vehicle and the trailer will result in inoperable lights and can lead to collision.

Before each tow, check that the tail lights, brake lights and turn signals work.

## TRAILER TOWING TIPS

Driving a vehicle with a trailer in tow is vastly different from driving the same vehicle without a trailer in tow. Acceleration, maneuverability and braking are all diminished with a trailer in tow.

It takes longer to get up to speed, you need more room to turn and pass, and more distance to stop when towing a trailer. You will need to spend time adjusting to the different feel and maneuverability of the tow vehicle with a loaded trailer.

Because of the significant differences in all aspects of maneuverability when towing a trailer, the hazards and risks of injury are also much greater than when driving without a trailer. You are responsible for keeping your vehicle and trailer in control, and for all the damage that is caused if you lose control of your vehicle and trailer.

As you did when learning to drive an automobile, find an open area with little or no traffic for your first practice trailering. Of course, before you start towing the trailer, you must follow all of the instructions for inspection, testing, loading and coupling. Also, before you start towing, adjust the mirrors so you can see the trailer as well as the area to the rear of it.

Drive slowly at first, 5 mph or so, and turn the wheel to get the feel of how the tow vehicle and trailer combination responds. Next, make some right and left hand turns. Watch in your side mirrors to see how the trailer follows the tow vehicle. Turning with a trailer attached requires more room.

Stop the rig a few times from speeds no greater than 10 mph. If your trailer is equipped with brakes, try using different combinations of trailer brake and tow vehicle brake. Note the effect that the trailer brakes have when they are the only brakes used. When properly adjusted, the trailer brakes will come on just before the tow vehicle brakes.

It will take practice to learn how to back up a tow vehicle with a trailer attached. Take it slow. Before backing up, get out of the tow vehicle and look behind the trailer to make sure that there are no obstacles.

Some drivers place their hands at the bottom of the steering wheel, and while the tow vehicle is in reverse, “think” of the hands as being on the top of the wheel. When the hands move to the right (counterclockwise, as you would do to turn the tow vehicle to the left when moving forward), the rear of the trailer moves to the right. Conversely, rotating the steering wheel clockwise with your hands at the bottom of the wheel will move the rear of the trailer to the left while backing up.

If you are towing a bumper hitch rig, be careful not to allow the trailer to turn too much because it will hit the rear of the tow vehicle. To straighten the rig, either pull forward or turn the steering wheel in the opposite direction.

### CAUTION

For Hydraulic Brake Models **ALWAYS** ensure that when backing up it is done in a slow, straight, and steady manner to safeguard the brakes from locking up.

## TRAILER VIN TAG

Figure A below is a sample of the Vehicle Identification Number (VIN) Tag which is typically located on the left front of the trailer. See Figure B for location.

MANUFACTURED BY / FABRIQUE PAR:		DATE	
GVWR / PNRV	KG ( LB)		
GVWR (EACH AXLE) / PNRE (CHAQUE ESSIEU)	KG ( LB)	TIRES / PNEŪS	
RIMS / JANTS			
COLD INFL. PRESS. / PRESS. DE GONFL. A FROID	NPA (	PSI / LPOŪS	<input type="checkbox"/> SINGLE <input type="checkbox"/> DUAL
<small>THIS VEHICLE CONFORMS TO ALL APPLICABLE U.S. FEDERAL MOTOR VEHICLE SAFETY STANDARDS IN EFFECT ON THE DATE OF MANUFACTURE SHOWN ABOVE. THIS VEHICLE CONFORMS TO ALL APPLICABLE STANDARDS PRESCRIBED UNDER THE CANADIAN MOTOR VEHICLE SAFETY REGULATIONS IN EFFECT ON THE DATE OF MANUFACTURE - CE VEHICULE EST CONFORME A TOUTES LES NORMES QUI LI SONT APPLICABLES EN VERTU DU RÈGLEMENT SUR LA SÉCURITÉ DES VEHICULES AUTOMOBILES DU CANADA EN VIGUEUR A LA DATE DE SA FABRICATION.</small>			
V.I.N. / N.I.V.:		TYPE / TYPE: TRAILER TRA / REM	FD-306 REV A

Figure A. Vehicle VIN Tag

# TRAILER SAFETY GUIDELINES

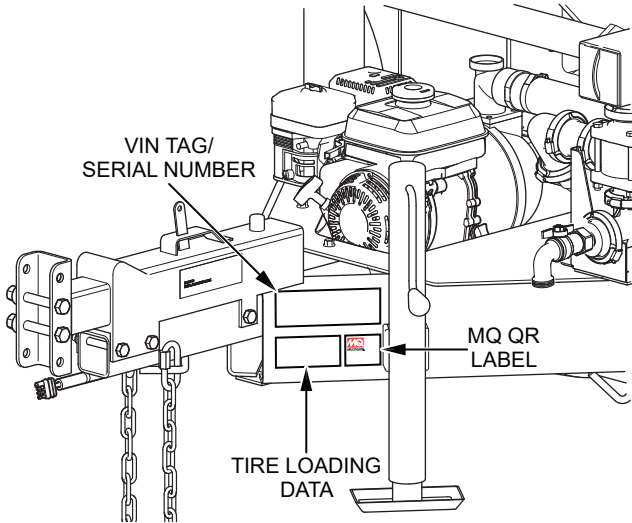

**Figure B. Typical VIN Tag Location**

The trailer VIN Tag contains the following critical safety information for the use of your trailer.

**GAWR:** The maximum gross weight that an axle can support. It is the lowest of axle, wheel, or tire rating.

Usually, the tire or wheel rating is lower than the axle rating, and determines GAWR.

**GVWR:** The maximum allowable gross weight of the trailer and its contents. The gross weight of the trailer includes the weight of the trailer and all of the items within it. GVWR is sometimes referred to as GTWR (Gross Trailer Weight Rating), or MGTW (Maximum Gross Trailer Weight). GVWR, GTWR and MGTW are all the same rating.

The sum total of the GAWR for all trailer axles may be less than the GVWR for the trailer, because some of the trailer load is to be carried by the tow vehicle, rather than by the trailer axle(s). The total weight of the cargo and trailer must not exceed the GVWR, and the load on an axle must not exceed its GAWR.

**PSIC:** The tire pressure (psi) measured when cold.

**VIN:** The Vehicle Identification Number.

**EMPTY WEIGHT:** Some information that comes with the trailer (such as the Manufacturer's Statement of Origin) is not a reliable source for "empty" or "net" weight. The shipping documents list average or standard weights and your trailer may be equipped with options.

To determine the "empty" or "net" weight of your trailer, weigh it on an axle scale. To find the weight of the trailer

using an axle scale, you must know the axle weights of your tow vehicle without the trailer coupled. Some of the trailer weight will be transferred from the trailer to the tow vehicle axles, and an axle scale weighs all axles, including the tow vehicle axles.

**SERIAL NUMBER:** The last five (5) numbers of the VIN Number are the Water Trailer Serial Number.

## TOW VEHICLE

The towing hitch attached to your tow vehicle must have a capacity equal to or greater than the load rating of the trailer you intend to tow. The hitch capacity must also be matched to the tow vehicle capacity. Your vehicle dealer can provide and install the proper hitch on your tow vehicle.

## SUSPENSION SYSTEM

Sway bars, shock absorbers, heavy duty springs, heavy duty tires and other suspension components may be required to sufficiently tow the trailer and pump.

## BRAKE CONTROLLER

For trailers equipped with electric brakes, the electric brake controller is part of the tow vehicle and is essential in the operation of the electric brakes on the trailer. The brake controller is not the same as the safety breakaway brake system that may be equipped on the trailer.

## SIDE VIEW MIRRORS

The size of the trailer that is being towed and your state law regulations determine the size of the mirrors. However, some states prohibit extended mirrors on a tow vehicle, except while a trailer is actually being towed. In this situation, detachable extended mirrors are necessary. Check with your dealer or the appropriate state agency for mirror requirements.

## HEAVY DUTY FLASHER

A Heavy Duty Flasher is an electrical component that may be required when your trailer turn signal lights are attached to the tow vehicle flasher circuit.

## ELECTRICAL CONNECTOR

An Electrical Connector connects the light and brake systems on the trailer to the light and brake controls on the towing vehicle.

# TRAILER SAFETY GUIDELINES

## EMERGENCY FLARES AND TRIANGLE REFLECTORS

It is wise to carry these warning devices even if you are not towing a trailer. It is particularly important to have these when towing a trailer because the hazard flashers of your towing vehicle will not operate for as long a period of time when the battery is running both the trailer lights and tow vehicle lights.

## SAFETY CHAINS

If the coupler connection comes loose, the safety chains can keep the trailer attached to the tow vehicle. With properly rigged safety chains, it is possible to keep the tongue of the trailer from digging into the road pavement, even if the coupler-to-hitch connection comes apart.

## TRAILER LIGHTING AND BRAKING CONNECTOR

A device that connects electrical power from the tow vehicle to the trailer. Electricity is used to turn on brake lights, running lights, and turn signals as required. In addition, if your trailer has a separate braking system, the electrical connector will also supply power to the brakes from the tow vehicle.

## BREAKAWAY SYSTEM

If the trailer coupler connection comes loose, the breakaway system can actuate emergency hydraulic brakes depending on the type of actuator on the trailer. The breakaway cable must be rigged to the tow vehicle with appropriate slack that will activate the system if the coupler connection comes loose.

## JACKSTAND

A device on the trailer that is used to raise and lower the coupler. The jack is sometimes called the "landing gear" or the "tongue jack."

## COUPLER TYPES

Five types of couplers are available.

- Ball Hitch Coupler, 2 5/16" Standard (EE43253)
- Pintel Eye Coupler, 3" Option (29369)
- Ball Hitch Coupler, 2" Option (29228)
- Ball Hitch Bulldog, 2" Option (EE57033)
- Ball Hitch Bulldog, 2 5/16" Option (EE56638)

## BALL HITCH COUPLER

A ball hitch coupler (Figure C) connects to a ball that is located on or under the rear bumper of the tow vehicle. This system of coupling a trailer to a tow vehicle is sometimes referred to as "bumper pull."

A ball hitch trailer may be fitted with a tongue jack that can raise and lower the coupler. The tongue jack is mounted to the A-frame (front or tongue) part of the trailer. By rotating the jack handle clockwise, the jack will extend and raise the tongue of the trailer.

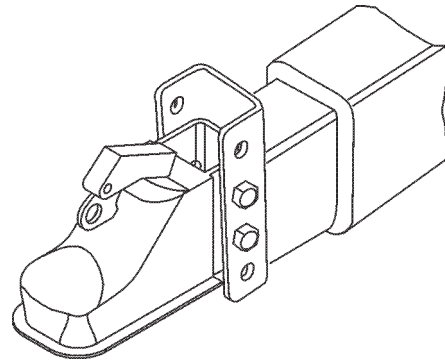

**Figure C. Ball Hitch Coupler**

Before each tow, coat the ball with a thin layer of automotive bearing grease to reduce wear and ensure proper operation. Check the locking device that secures the coupler to the ball for proper operation.

If you see or feel evidence of wear, such as flat spots, deformations, pitting or corrosion, on the ball or coupler, immediately have your dealer inspect them to determine the proper action to prevent possible failure of the ball and coupler system. All bent or broken coupler parts must be replaced before towing the trailer.

The coupler handle lever must be able to rotate freely and automatically snap into the latched position. Oil the pivot points, sliding surfaces, and spring ends with SAE 30W motor oil. Keep the ball socket and latch mechanism clean. Dirt or contamination can prevent proper operation of the latching mechanism.

The load rating of the coupler and the necessary ball size are listed on the trailer tongue. You must provide a hitch and ball for your tow vehicle where the load rating of the hitch and ball is equal to or greater than that of your trailer.

Also, the ball size must be the same as the coupler size. If the hitch ball is too small, too large, is underrated, is loose



# TRAILER SAFETY GUIDELINES

or is worn, the trailer can come loose from the tow vehicle and may cause death or serious injury.

THE TOW VEHICLE, HITCH AND BALL MUST HAVE A RATED TOWING CAPACITY EQUAL TO OR GREATER THAN THE TRAILER **Gross Vehicle Weight Rating (GVWR)**. IT IS ESSENTIAL THAT THE HITCH BALL BE OF THE SAME SIZE AS THE COUPLER.

The ball size and load rating (capacity) are marked on the ball. Hitch capacity is marked on the hitch.

## **! WARNING**

Coupler-to-hitch mismatch can result in uncoupling, leading to death or serious injury.

Be sure the **LOAD RATING** of the hitch ball is equal to or greater than the load rating of the coupler.

Be sure the **SIZE** of the hitch ball matches the size of the ball coupler.

## **! WARNING**

A worn, cracked or corroded hitch ball can fail while towing and may result in death or serious injury.

Before coupling trailer, inspect the hitch ball for wear, corrosion and cracks.

Replace worn or damaged hitch ball.

## **! WARNING**

A loose hitchball nut can result in uncoupling, leading to death or serious injury.

Be sure the hitch ball is tight to the hitch before coupling the trailer.

- Rock the ball to make sure it is tightened to the hitch, and visually check that the hitch ball nut is solid against the lock washer and hitch frame.
- Wipe the inside and outside of the coupler. Clean and visually inspect it for cracks and deformations. Feel the inside of the coupler for worn spots and pits.
- Be sure the coupler is secured tightly to the tongue of the trailer. All coupler fasteners must be visibly solid against the trailer frame.
- The bottom surface of the coupler must be above the top of the hitch ball. Use the tongue jackstand to support

the trailer tongue. Wood or concrete blocks may also be used.

## **Coupling the Trailer to the Tow Vehicle (Ball Coupler)**

- Lubricate the hitch ball and the inside of the coupler with a thin layer of automotive bearing grease.
- Slowly back up the tow vehicle so that the hitch ball is near or aligned under the coupler.
- Using the jackstand at the front of the trailer (tongue), turn the jackstand crank handle to raise the trailer. If the ball coupler does not line up with the hitch ball, adjust the position of the tow vehicle.
- Open the coupler locking mechanism. Ball couplers have a locking mechanism with an internal moving piece and an outside handle. In the open position, the coupler is able to drop fully onto the hitch ball.
- Lower the trailer (Figure D) until the coupler fully engages the hitch ball.

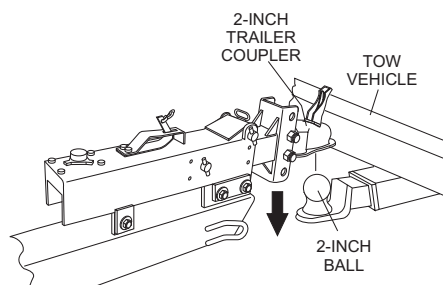

**Figure D. Ball Hitch Coupling Mechanism**

- Engage the coupler locking mechanism. In the engaged position, the locking mechanism securely holds the coupler to the hitch ball.
- Insert a pin or lock through the hole in the locking mechanism.
- Be sure the coupler is all the way on the hitch ball and the locking mechanism is engaged. A properly engaged locking mechanism will allow the coupler to raise the rear of the tow vehicle. Using the trailer jackstand, verify that you can raise the rear of the tow vehicle by 1 inch after the coupler is locked to the hitch.
- Lower the trailer so that its entire tongue weight is held by the hitch.
- Raise the jackstand to a height where it will not interfere with the road.

# TRAILER SAFETY GUIDELINES

## NOTICE

Overloading can damage the tongue jack. **DO NOT** use the tongue jack to raise the tow vehicle more than one inch.

If the coupler cannot be secured to the hitch ball, do not tow the trailer. Call your dealer for assistance. Lower the trailer so that its entire tongue weight is held by the hitch and continue retracting the jack to its fully retracted position.

## Attaching Safety Chain

Visually inspect the safety chains and hooks for wear or damage. Replace worn or damaged safety chains and hooks before towing.

Attach the safety chains so that they:

- Cross underneath the coupler. See Figure E.

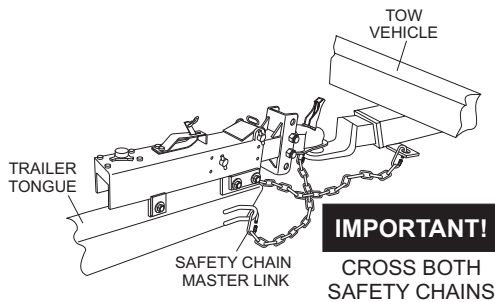

**Figure E. Attaching Safety Chain (Ball Hitch)**

- Loop around a frame member of the tow vehicle or holes provided in the hitch system (**DO NOT** attach them to an interchangeable part of the hitch assembly).
- Have enough slack to permit tight turns, but not be close to the road surface, so if the trailer uncouples, the safety chains can hold the tongue up above the road.

## WARNING

Improper rigging of the safety chains can result in loss of control of the trailer and tow vehicle, leading to death or serious injury, if the trailer uncouples from the tow vehicle.

- Fasten chains to frame of tow vehicle. **DO NOT** fasten chains to any part of the hitch unless the hitch has holes or loops specifically for that purpose.
- Cross chains underneath hitch and coupler with enough slack to permit turning and to hold tongue up, if the trailer comes loose.

## Breakaway Brake System

If the coupler or hitch fails, a properly connected and working breakaway brake system (Figure F) will apply the hydraulic brakes on the trailer. The safety chains will keep the tow vehicle attached and as the brakes are applied at the trailer's axles, the trailer/tow vehicle combination will come to a controlled stop.

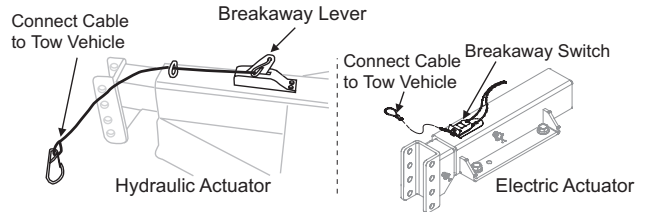

**Figure F. Breakaway Brake System**

## Breakaway Cable Surge Brake System

The breakaway brake system includes a brake cable connected to the tow vehicle on one end and to the emergency brake lever located on the hydraulic actuator on the other end.

## WARNING

- An ineffective breakaway brake system can result in a runaway trailer, leading to death or serious injury, if the coupler or ball hitch fails.
- Connect the breakaway cable to the tow vehicle and **NOT** to the hitch, ball or support.
- Before towing the trailer, test the function of the breakaway brake system. If the breakaway brake system is not working, **DO NOT** tow the trailer. Have it serviced or repaired.

## NOTICE

**DO NOT** tow the trailer with the breakaway brake system **ON** because the brakes will overheat which can result in permanent brake failure.

## NOTICE

Replace the breakaway brake battery (if equipped) at intervals specified by manufacturer.

# TRAILER SAFETY GUIDELINES

## Connecting Trailer Lights

Connect the trailer lights to the tow vehicle's electrical system using the electric connectors at the front of the trailer (tongue). Refer to the wiring diagram shown in the trailer wiring diagram section of this manual. Before towing the trailer check for the following:

- Running Lights (turn on tow vehicle headlights).
- Brake Lights (step on tow vehicle brake pedal).
- Backup Lights (place tow vehicle gear shift in reverse).
- Turn Signals (activate tow vehicle directional signal lever).

### **WARNING**

Improper electrical connection between the tow vehicle and the trailer will result in inoperable lights and electric brakes, and can lead to collision.

Before each tow:

- Check that the taillights, brake lights and turn signals work.
- Check that the electric brakes work by operating the brake controller inside the tow vehicle.

## Uncoupling the Ball Hitch

Follow these steps to uncouple ball hitch from tow vehicle:

- Block trailer tires to prevent the trailer from rolling, before jacking the trailer up.
- Disconnect the electrical connector.
- Disconnect the breakaway brake switch cable. Promptly replace the pullpin in the switchbox.
- Before extending jackstand, make certain the ground surface below the jackstand foot will support the tongue load.
- Rotate the jackstand handle (or crank) clockwise. This will slowly extend the jack and transfer the weight of the trailer tongue to the jack.

## PINTLE HITCH COUPLER

A pintle eye coupler (Figure G) connects to a pintle-hook hitch that is located on or under the rear bumper of the tow vehicle. This system of coupling a trailer to a tow vehicle is sometimes referred to as a “lunette eye, tow ring or G.I. hitch.”

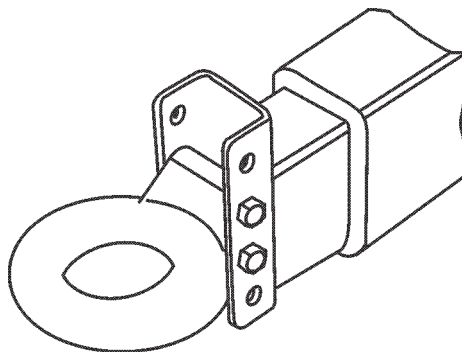

**Figure G. Pintle Hitch Coupler**

A pintle hitch trailer may be fitted with a tongue jackstand that can raise and lower the coupler. The tongue jack is mounted to the A-frame (front or tongue) part of the trailer. By rotating the jack handle clockwise, the jack will extend and raise the tongue of the trailer.

The load rating of the coupler and the necessary pintle hitch size are listed on the trailer tongue. You must provide a pintle hitch and pintle coupler for your tow vehicle, where the load rating of the pintle hitch and pintle coupler is equal to or greater than that of your trailer.

Also, the pintle hitch size must be the same as the pintle coupler size. If the hitch is too small, too large, underrated, loose or worn, the trailer can come loose from the tow vehicle, and may cause death or serious injury.

## Pintle Coupler and Pintle Hook

Before each tow, check the locking device that secures the coupler to the pintle hook assembly.

The pintle hook lever must be able to operate freely and automatically snap into place into the latched position. Lightly oil the pivot points and sliding surfaces with SAE30W motor oil to prevent rust and help ensure proper operation of the latching mechanism.

If you see or feel evidence of wear, such as flat spots, deformations, pitting or corrosion, on the pintle hook or coupler, immediately have your dealer inspect them to determine the proper action to prevent possible failure of

# TRAILER SAFETY GUIDELINES

the ball and coupler system. All bent or broken coupler parts must be replaced before towing the trailer.

THE TOW VEHICLE, PINTLE HITCH AND PINTLE COUPLER MUST HAVE A RATED TOWING CAPACITY EQUAL TO OR GREATER THAN THE TRAILER **Gross Vehicle Weight Rating (GVWR)**.

IT IS ESSENTIAL THAT THE PINTLE HITCH BE OF THE SAME SIZE AS THE PINTLE COUPLER.

The coupler size and load rating (capacity) are marked on the coupler. Hitch capacity is marked on the hitch.

## WARNING

Coupler-to-hitch mismatch can result in uncoupling, leading to death or serious injury.

Be sure the **LOAD RATING** of the pintle hitch hook is equal to or greater than the load rating of the pintle eye coupler.

Be sure the **SIZE** of the pintle hitch hook matches the size of the pintle eye coupler.

## WARNING

A worn, cracked or corroded pintle hitch hook can fail while towing, and may result in death or serious injury.

Before coupling trailer, inspect the pintle hitch hook for wear, corrosion and cracks.

Replace worn or damaged pintle hitch hook.

- Rock the pintle eye coupler to make sure it is secured tightly to the hitch.
- Wipe the inside and outside of the pintle coupler. Clean and inspect it visually for cracks and deformations. Feel the inside of the coupler for worn spots and pits.
- Be sure the coupler is secured tightly to the tongue of the trailer. All coupler fasteners must be visibly solid against the trailer frame.
- Raise the bottom surface of the coupler to be above the top of the pintle hitch hook. Use the tongue jackstand to support the trailer tongue. Wood or concrete blocks may also be used.

## WARNING

A defective pintle hitch not properly fastened can result in uncoupling, leading to death or serious injury.

Be sure the pintle hook is securely tightened to the tow vehicle before coupling the trailer.

## Coupling Trailer to Tow Vehicle (Pintle Coupler)

- Slowly back up the tow vehicle so that the pintle hitch hook is near or aligned under the pintle eye ring coupler.
- Using the jackstand at the front of the trailer (tongue), turn the jackstand crank handle to raise the trailer. If the pintle eye coupler does not line up with the pintle hitch hook, adjust the position of the tow vehicle.
- **OPEN** the pintle hook locking mechanism (Figure H). Place the hook inside the eye coupler. **CLOSE** the pintle hook mechanism.

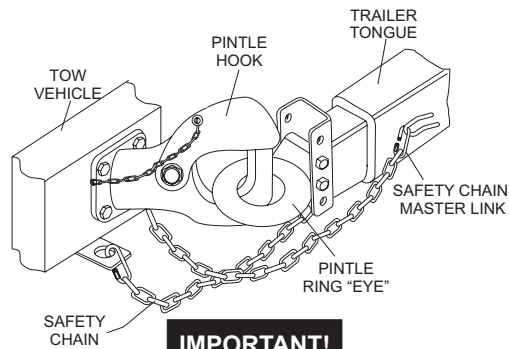

## IMPORTANT!

CROSS BOTH SAFETY CHAINS

## Figure H. Attaching Safety Chain (Pintle Hitch)

- Insert a pin or lock through the hole in the locking mechanism.
- Be sure the pintle hook is inserted completely through the eye ring and the locking mechanism is engaged. A properly engaged locking mechanism will allow the coupler to raise the rear of the tow vehicle. Using the trailer jack, test to see that you can raise the rear of the tow vehicle by 1 inch after the coupler is locked to the hitch.
- Lower the trailer so that its entire tongue weight is held by the hitch.
- Raise the jackstand to a height where it will not interfere with the road.

# TRAILER SAFETY GUIDELINES

## TIRE SAFETY

### Unsafe Tires, Lug Nuts or Wheels

Trailer tires and wheels are more likely to fail than car tires and wheels because they carry a heavier load. Therefore, it is essential to inspect the trailer tires before each tow.

If a tire has a bald spot, bulge, cuts, is showing any cords, or is cracked, replace the tire before towing. If a tire has uneven tread wear, take the trailer to a dealer service center for diagnosis.

Uneven tread wear can be caused by tire imbalance, axle misalignment or incorrect inflation.

Tires with too little tread will not provide adequate tracking on wet roadways and can result in loss of control, leading to death or serious injury.

Improper tire pressure causes an unstable trailer and can result in a tire blowout and loss of control. Therefore, before each tow you must also check the tire pressure. Tire pressure must be checked when tires are cold.

Allow 3 hours cool-down after driving as much as 1 mile at 40 mph before checking tire pressure. Trailer tires will be inflated to higher pressures than passenger vehicle tires.

Since trailer wheels and lug nuts (or bolts) are subjected to greater side loads than automobile wheels, they are more prone to loosen. Before each tow, check to make sure they are tight.

The proper tightness (torque) for lug nuts is listed in the lug nut tightening section of this manual. Use a torque wrench to tighten the lug nuts. If you do not have a torque wrench, use a lug wrench (from your tow vehicle) and tighten the nuts as much as you can. Then have a service garage or trailer dealer tighten the lug nuts to the proper torque.

#### WARNING

Metal creep between the wheel rim and lug nuts will cause the rim to loosen and could result in a wheel coming off, leading to death or serious injury.

Tighten lug nuts before each tow.

Lug nuts are also prone to loosen after first being assembled. When driving a new trailer (or after wheels have been remounted), check to make sure they are tight after the first 10, 25 and 50 miles of driving and before each tow thereafter.

Failure to perform this check can result in a wheel parting from the trailer and a crash, leading to death or serious injury.

#### WARNING

Lug nuts are prone to loosen after initial installation, which can lead to death or serious injury.

Check lug nuts for tightness on a new trailer or when wheel(s) have been remounted after the first 10, 25 and 50 miles of driving.

#### WARNING

Improper lug nut torque can cause a wheel parting from the trailer, leading to death or serious injury.

Be sure lug nuts are tight before each tow.

#### WARNING

Improper tire pressure can result in a blowout and loss of control, which can lead to death or serious injury.

Be sure tires are inflated to pressure indicated on side wall before towing trailer.

### Determining Load Limit of Trailer

Determining the load limits of a trailer includes more than understanding the load limits of the tires alone. On all trailers there is a federal certification/VIN label that is located on the forward half of the left (road) side of the unit. This certification/VIN label will indicate the trailer's Gross Vehicle Weight Rating (GVWR). This is the most weight the fully loaded trailer can weigh. It will also provide the Gross Axle Weight Rating (GAWR). This is the most the axle can weigh.

# TRAILER SAFETY GUIDELINES

There is a vehicle placard (Figure I) located in the same location as the certification label described above. This placard provides tire and loading information. In addition, this placard will show a statement regarding maximum cargo capacity.

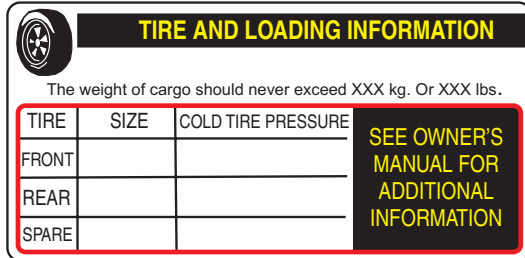

**Figure I. Trailer Tire Placard**

If additional work items (hoses, tools, clamps, etc.) are going to be added to the trailer, be sure they are distributed evenly to prevent overloading front to back and side to side. Heavy items should be placed low and as close to the axle positions as reasonable. Too many items on one side may overload a tire.

Excessive loads and/or underinflation cause tire overloading and, as a result, abnormal tire flexing occurs. This situation can generate an excessive amount of heat within the tire. Excessive heat may lead to tire failure. It is the air pressure that enables a tire to support the load, so proper inflation is critical. The proper air pressure may be found on the certification/VIN label and/or on the Tire and Loading Information placard. This value should never exceed the maximum cold inflation pressure stamped on the tire.

Perform the following steps to determine the load limit of your trailer.

## Step 1.

Locate the statement, “The weight of cargo should never exceed XXX kg or XXX lbs.,” on your vehicle’s Tire and Loading Information placard (Figure I). This value equals the available amount of equipment load capacity.

## Step 2.

Determine the weight of the equipment being loaded on the tow vehicle. That weight may not safely exceed the available equipment load capacity. The trailer’s Tire Information Placard is attached adjacent to or near the trailer’s VIN (Certification) label at the left front of the trailer (See Figure I).

## Determining Load Limit of Tow Vehicle

### Step 1.

Locate the statement, “The combined weight of occupants and cargo should never exceed XXX lbs.,” on your vehicle’s placard.

### Step 2.

Determine the combined weight of the driver and passengers who will be riding in your vehicle.

### Step 3.

Subtract the combined weight of the driver and passengers from XXX kilograms or XXX pounds.

### Step 4.

The resulting figure equals the available amount of cargo and luggage capacity. For example, if the “XXX” amount equals 1,400 lbs. and there will be five 150 lb. passengers in your vehicle, the amount of available cargo and luggage capacity is 650 lbs. (1,400–750 (5 × 150) = 650 lbs.)

### Step 5.

Determine the combined weight of luggage and cargo being loaded on the vehicle. That weight may not safely exceed the available cargo and luggage capacity calculated in Step 4.

If your vehicle will be towing a trailer, load from your trailer will be transferred to your vehicle. Consult the tow vehicle’s manual to determine how this weight transfer reduces the available cargo and luggage capacity of your vehicle.

Studies of tire safety show that maintaining proper tire pressure, observing tire and vehicle load limits (not carrying more weight in your vehicle than your tires or vehicle can safely handle), avoiding road hazards and inspecting tires for cuts, slashes and other irregularities are the most important things you can do to avoid tire failure, such as tread separation or blowout and flat tires. These actions, along with other care and maintenance activities, can also:

- Improve vehicle handling.
- Help protect you and others from avoidable breakdowns and accidents.
- Improve fuel economy.
- Increase the tire life.

# TRAILER SAFETY GUIDELINES

Use the information contained in this section to make tire safety a regular part of your vehicle maintenance routine. Recognize that the time you spend is minimal compared with the inconvenience and safety consequences of a flat tire or other tire failure.

## TIRE FUNDAMENTALS

Federal law requires tire manufacturers to place standardized information on the sidewall of all tires (Figure J). This information identifies and describes the fundamental characteristics of the tire and also provides a tire identification number for safety standard certification and in case of a recall.

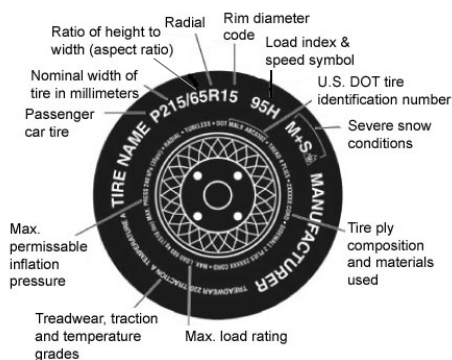

**Figure J. Standard Tire Sidewall Information**

**P:** The “P” indicates the tire is for passenger vehicles.

**Next number:** This three-digit number gives the width in millimeters of the tire from sidewall edge to sidewall edge. In general, the larger the number, the wider the tire.

**Next number:** This two-digit number, known as the aspect ratio, gives the tire’s ratio of height to width. Numbers of 70 or lower indicate a short sidewall for improved steering response and better overall handling on dry pavement.

**P:** The “R” stands for radial. Radial ply construction of tires has been the industry standard for the past 20 years.

**Next number:** This two-digit number is the wheel or rim diameter in inches. If you change your wheel size, you will have to purchase new tires to match the new wheel diameter.

**Next number:** This two- or three-digit number is the tire’s load index. It is a measurement of how much weight each tire can support. You may find this information in your owner’s manual. If not, contact a local tire dealer. *Note:* You may not find this information on all tires because it is not required by law.

**M+S:** The “M+S” or “M/S” indicates that the tire has some mud and snow capability. Most radial tires have these markings; hence, they have some mud and snow capability.

**Speed Rating:** The speed rating denotes the speed at which a tire is designed to be driven for extended periods of time. The ratings range from 99 miles per hour (mph) to 186 mph. These ratings are listed in Table A. *Note:* You may not find this information on all tires because it is not required by law.

Letter Rating	Speed Rating
Q	99 mph
R	106 mph
S	112 mph
T	118 mph
U	124 mph
H	130 mph
V	149 mph
W	168* mph
Y	186* mph

**U.S. DOT Tire Identification Number:** This begins with the letters “DOT” and indicates that the tire meets all federal standards. The next two numbers or letters are the plant code where it was manufactured, and the last four numbers represent the week and year the tire was built. For example, the numbers 3197 means the 31st week of 1997. The other numbers are marketing codes used at the manufacturer’s discretion. This information is used to contact consumers if a tire defect requires a recall.

**Tire Ply Composition and Materials Used:** The number of plies indicates the number of layers of rubber-coated fabric in the tire. In general, the greater the number of plies, the more weight a tire can support. Tire manufacturers also must indicate the materials in the tire, which include steel, nylon, polyester, and others.

**Maximum Load Rating:** This number indicates the maximum load in kilograms and pounds that can be carried by the tire.

**Maximum Permissible Inflation Pressure:** This number is the greatest amount of air pressure that should ever be put in the tire under normal driving conditions.

# TRAILER SAFETY GUIDELINES

## Uniform Tire Quality Grading Standards (UTQGS)

**Treadwear Number:** This number indicates the tire’s wear rate. The higher the treadwear number is, the longer it should take for the tread to wear down. For example, a tire graded 400 should last twice as long as a tire graded 200.

**Traction Letter:** This letter indicates a tire’s ability to stop on wet pavement. A higher graded tire should allow you to stop your car on wet roads in a shorter distance than a tire with a lower grade. Traction is graded from highest to lowest as “AA,” “A,” “B,” and “C.”

**Temperature Letter:** This letter indicates a tire’s resistance to heat. The temperature grade is for a tire that is inflated properly and not overloaded. Excessive speed, underinflation or excessive loading, either separately or in combination, can cause heat build-up and possible tire failure. From highest to lowest, a tire’s resistance to heat is graded as “A,” “B,” or “C.”

Refer to Figure K for additional tire information for light trucks.

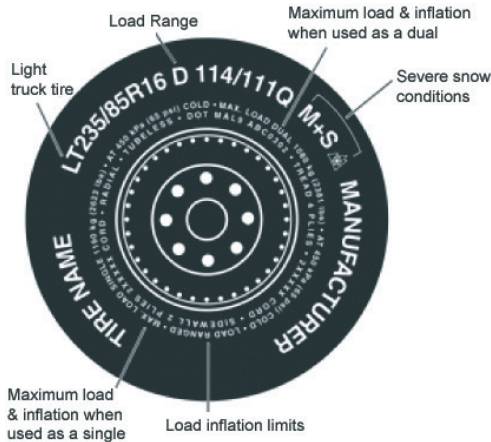

**Figure K. UTQGS Tire Information**

Tires for light trucks have other markings besides those found on the sidewalls of passenger tires.

**LT:** The “LT” indicates the tire is for light trucks or trailers.

**ST:** An “ST” is an indication the tire is for trailer use only.

**Max. Load Dual** kg (lbs) at kPa (psi) Cold: This information indicates the maximum load and tire pressure when the tire is used as a dual, that is, when four tires are put on each rear axle (a total of six or more tires on the vehicle).

**Max. Load Single** kg (lbs) at kPa (psi) Cold: This information indicates the maximum load and tire pressure when the tire is used as a single.

**Load Range:** This information identifies the tire’s load-carrying capabilities and its inflation limits.

## Tire Safety Tips

- Slow down if you have to go over a pothole or other object in the road.
- **DO NOT** run over curbs or other foreign objects in the roadway, and try not to strike the curb when parking.
- Check tire inflation pressure weekly during use to ensure the maximum tire life and tread wear.
- **DO NOT** bleed air from tires when they are hot.
- Inspect tires for uneven wear patterns on the tread, cracks, foreign objects, or other signs of wear or trauma.
- Remove bits of glass and foreign objects wedged in the tread.
- Make sure your tire valves have valve caps.
- **ALWAYS** check tire pressure on tow vehicle and trailer before towing. Check tire pressure at least once a month.
- **DO NOT** overload tow vehicle. Check the tire information and loading placard for safe allowable tire loading conditions.

## Tire Repair

The proper repair of a punctured tire requires a plug for the hole and a patch for the area inside the tire that surrounds the puncture hole. Punctures through the tread can be repaired if they are not too large, but punctures to the sidewall should not be repaired. Tires must be removed from the rim to be properly inspected before being plugged and patched.







## Replacing Worn or Damaged Tires

Replace the tire before towing the trailer if the tire treads have less than 1/16 inch depth or the telltale bands are visible. Check inflation pressure weekly during use to ensure the maximum tire life and tread wear. A bubble, cut or bulge in a side wall can result in a tire blowout. Inspect both side walls of each tire for any bubble, cut or bulge, and replace a damaged tire before towing the trailer.



# TRAILER SAFETY GUIDELINES

Table B below will help pinpoint the causes and solutions of tire wear problems.

Table B. Tire Wear Troubleshooting			
Wear Pattern		Cause	Solution
	Center Wear	Over inflation.	Adjust pressure to particular load per tire manufacturer.
	Edge Wear	Under inflation.	Adjust pressure to particular load per tire manufacturer.
	Side Wear	Loss of camber or overloading.	Make sure load does not exceed axle rating. Align wheels.
	Toe Wear	Incorrect toe-in.	Align wheels.
	Cupping	Out-of-balance.	Check bearing adjustment and balance tires.
	Flat Spots	Wheel lockup and tire skidding.	Avoid sudden stops when possible and adjust brakes.

**WARNING**



**ALWAYS** wear safety glasses when removing or installing force-fitted parts. **DO NOT** attempt to repair or modify a wheel. **DO NOT** install an inner-tube to correct a leak through the rim. If the rim is cracked, the air pressure in the inner tube may cause pieces of the rim to explode (break off) with great force and cause serious eye or bodily injury.

## Wheel Rims

If the trailer has been struck, or impacted, on or near the wheels, or if the trailer has struck a curb, inspect the rims for damage (i.e. being out of round), and replace any damaged wheel. Inspect the wheels for damage every year, even if no obvious impact has occurred.

## Wheels, Bearings and Lug Nuts

A loose, worn or damaged wheel bearing is the most common cause of brakes that grab.

To check wheel bearings, jack trailer and check wheels for side-to-side looseness. If the wheels are loose, or spin with a wobble, the bearings must be serviced or replaced. Check inflation pressure weekly during use to ensure the maximum tire life and tread wear. Most trailer axles are built with sealed bearings that are not serviceable. Sealed bearings must be replaced as complete units.

### NOTICE

**NEVER** use a pneumatic air gun to tighten wheel lug nuts.

Over-tightening lug nuts will result in breaking the studs or permanently deforming the mounting stud holes in the wheels.

### WARNING

Lug nuts are prone to loosen after initial installation, which can lead to death or serious injury. Check all wheel lug nuts periodically.

## Lug Nut Torque Requirements

It is extremely important to apply and maintain proper wheel mounting torque on the trailer. Be sure to use only the fasteners matched to the cone angle of the wheel. Proper procedure for attachment of the wheels is as follows:

1. Start all wheel lug nuts by hand.
2. Torque all lug nuts in sequence. See Figure L. **DO NOT** torque the wheel lug nuts all the way down. Tighten each lug nut in 3 separate passes as defined by Table C.
3. Check to see if the lug nuts are tight after the first 10, 25 and 50 miles of driving and before each tow thereafter.

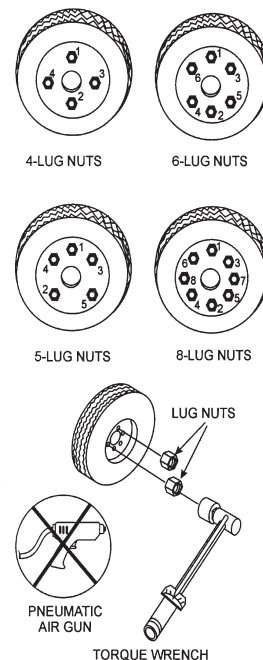

Figure L. Wheel Lug Nuts Tightening Sequence

# TRAILER SAFETY GUIDELINES

**Table C. Tire Torque Requirements**

Wheel Size	First Pass FT-LBS	Second Pass FT-LBS	Third Pass FT-LBS
12"	20-25	35-40	50-65
13"	20-25	35-40	50-65
14"	20-25	50-60	90-120
15"	20-25	50-60	90-120
16"	20-25	50-60	90-120

Replace any broken or burned-out lamps as necessary. Check the wire harness for cuts, fraying or other damage. If it needs replacing, contact your dealer.

**WARNING**

Improper operating taillights, stoplights and turn signals can cause collisions.

Check all lights before each tow.

**NOTICE**

The WT5C and WTE5C come standard with a flat 4-pin molded connector. The 6 and 7-pin connectors are illustrated for your information.

## Lights and Signals

Before each tow, check the trailer taillights, stoplights, turn signals and any clearance lights for proper operation.

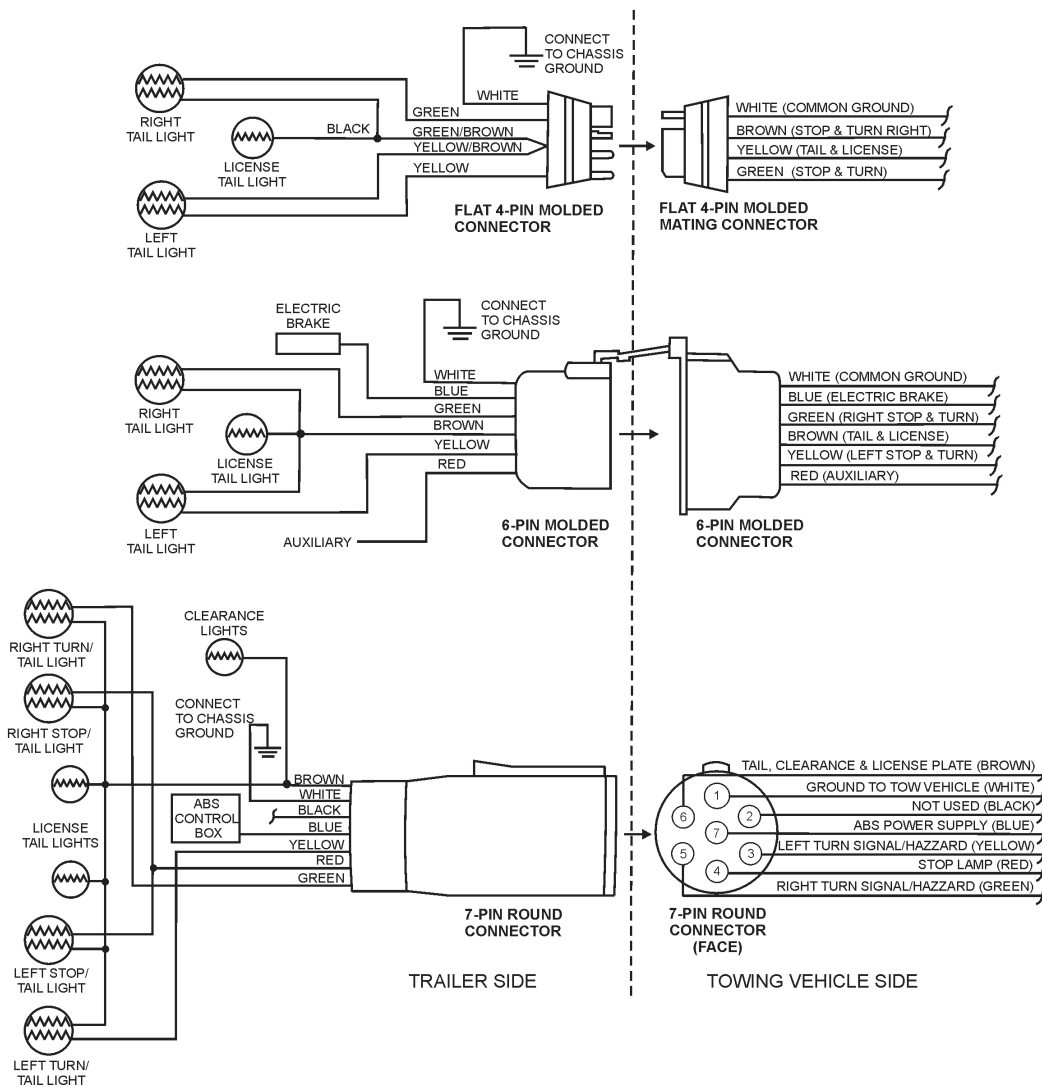

**Figure M. Trailer to Tow Vehicle Wiring Diagram**

# TROUBLESHOOTING

<b>Troubleshooting (Pump)</b>		
<b>Symptom</b>	<b>Possible Problem</b>	<b>Solution</b>
Pump Fails To Start	Incorrect voltage/amps?	Check that proper voltage is being supplied to the pump. Also check that there is an adequate amount of current (amps) to run the pump. Check power source circuit breaker.
	Check electrical connections?	If using float switches check wiring, inspect power cord.
	Blown power fuse?	Replace fuse, check cause of blown fuse.
	Impeller locked?	Disconnect power cord and check for clogging and improper impeller clearance. Unclog pump. Check overload protection device.
	Wet motor windings?	Use multimeter to check motor insulation. Insulation resistance must be greater than 15 megaohms. If resistance is low, disassemble pump motor and bake windings to dry them.
	Defective motor and pump bearings?	Check for excessive bearing wear. If worn, replace bearings. Replace motor if defective.
Pump Fails to Deliver Full Output	Twisted or restricted discharge hose?	Lay hose flat unkinked. Remove clog from hose line.
	Clogged pump strainer?	Clean strainer.
	Low voltage?	Use a voltmeter to check voltage while pump is energized. Voltage must be within $\pm 10\%$ . Check power source (no load and load). If an extension cord is used, make sure it has adequate current-carrying capacity for the required length. See Cord Length and Sizes Table.
	Impeller worn?	Replace impeller.
Water in Seal Oil	Defective water seal?	Replace water seal.
	Loose Oil Fill Plug?	Tighten securely.

# TROUBLESHOOTING

<b>Troubleshooting (Engine)</b>		
<b>Symptom</b>	<b>Possible Problem</b>	<b>Solution</b>
Difficult to start, fuel is available, but no spark at spark plug.	Spark plug bridging?	Check gap, insulation or replace spark plug.
	Carbon deposit on spark plug?	Clean or replace spark plug.
	Short circuit due to deficient spark plug insulation?	Check spark plug insulation, replace if worn.
	Improper spark plug gap?	Set to proper gap.
	Spark plug is red?	Check transistor ignition unit.
	Spark plug is bluish white?	If insufficient compression, repair or replace engine. If injected air leaking, correct leak. If carburetor jets clogged, clean carburetor.
	No spark present at tip of spark plug?	Check if transistor ignition unit is broken, and replace defective unit. Check if voltage cord cracked or broken and replace. Check if spark plug is fouled and replace.
	No oil?	Add oil as required.
	Oil pressure alarm lamp blinks upon starting? (if applicable)	Check automatic shutdown circuit, oil sensor. (if applicable)
Difficult to start, fuel is available, and spark is present at the spark plug.	ON/OFF switch is shorted?	Check switch wiring, replace switch.
	Ignition coil defective?	Replace ignition coil.
	Improper spark gap, points dirty?	Set correct spark gap and clean points.
	Condenser insulation worn or short circuiting?	Replace condenser.
	Spark plug wire broken or short circuiting?	Replace defective spark plug wiring.
Difficult to start, fuel is available, spark is present and compression is normal.	Wrong fuel type?	Flush fuel system, replace with correct type of fuel.
	Water or dust in fuel system?	Flush fuel system.
	Air cleaner dirty?	Clean or replace air cleaner.
	Choke open?	Close choke.
Difficult to start, fuel is available, spark is present and compression is low.	Suction/exhaust valve stuck or protruded?	Reseat valves.
	Piston ring and/or cylinder worn?	Replace piston rings and/or piston.
	Cylinder head and/or spark plug not tightened properly?	Torque cylinder head bolts and spark plug.
	Head gasket and/or spark plug gasket damaged?	Replace head and spark plug gaskets.
No fuel present at carburetor.	No fuel in fuel tank?	Fill with correct type of fuel.
	Fuel cock does not open properly?	Apply lubricant to loosen fuel cock lever, replace if necessary.
	Fuel filter/lines clogged?	Replace fuel filter.
	Fuel tank cap breather hole clogged?	Clean or replace fuel tank cap.
	Air in fuel line?	Bleed fuel line.



# OPERATION MANUAL

## HERE'S HOW TO GET HELP

PLEASE HAVE THE MODEL AND SERIAL  
NUMBER ON-HAND WHEN CALLING

### UNITED STATES

#### *Multiquip Inc.*

(310) 537- 3700  
6141 Katella Avenue Suite 200  
Cypress, CA 90630  
E-MAIL: mq@multiquip.com  
WEBSITE: www.multiquip.com

### CANADA

#### *Multiquip*

(450) 625-2244  
4110 Industriel Boul.  
Laval, Quebec, Canada H7L 6V3  
E-MAIL: infocanada@multiquip.com

### UNITED KINGDOM

#### *Multiquip (UK) Limited Head Office*

0161 339 2223  
Unit 2, Northpoint Industrial Estate,  
Globe Lane,  
Dukinfield, Cheshire SK16 4UJ  
E-MAIL: sales@multiquip.co.uk

© COPYRIGHT 2021, MULTIQUIP INC.

Multiquip Inc, the MQ logo are registered trademarks of Multiquip Inc. and may not be used, reproduced, or altered without written permission. All other trademarks are the property of their respective owners and used with permission.

This manual MUST accompany the equipment at all times. This manual is considered a permanent part of the equipment and should remain with the unit if resold.

The information and specifications included in this publication were in effect at the time of approval for printing. Illustrations, descriptions, references and technical data contained in this manual are for guidance only and may not be considered as binding. Multiquip Inc. reserves the right to discontinue or change specifications, design or the information published in this publication at any time without notice and without incurring any obligations.

Your Local Dealer is:



**PN: 49858**