



DEF REPLENISHMENT SYSTEM

Reduce service costs and
extend equipment runtimes.



At last. A Tank. Built like a Tank.

Reduce service calls and extend generator run times with the DEFTANK automatic DEF replenishment system.

Place on site and utilize its automatic dispensing capability, or load into truck bed for use as a mobile pumping station.

- **High capacity tank** holds up to 100 gallons (379 l) of DEF.
- **Compact design** simplifies transport and placement on site.
- **CAN bus DEF level monitoring** for any Tier 4 Final diesel engine.
- **Application Flexibility** — automatically maintains DEF level on one or two engines simultaneously, unattended.*
- **Extends engine runtime** and reduces the frequency of costly refilling.
- **Automatically purges supply lines** to ensure that DEF quality is maintained after each replenishment cycle.

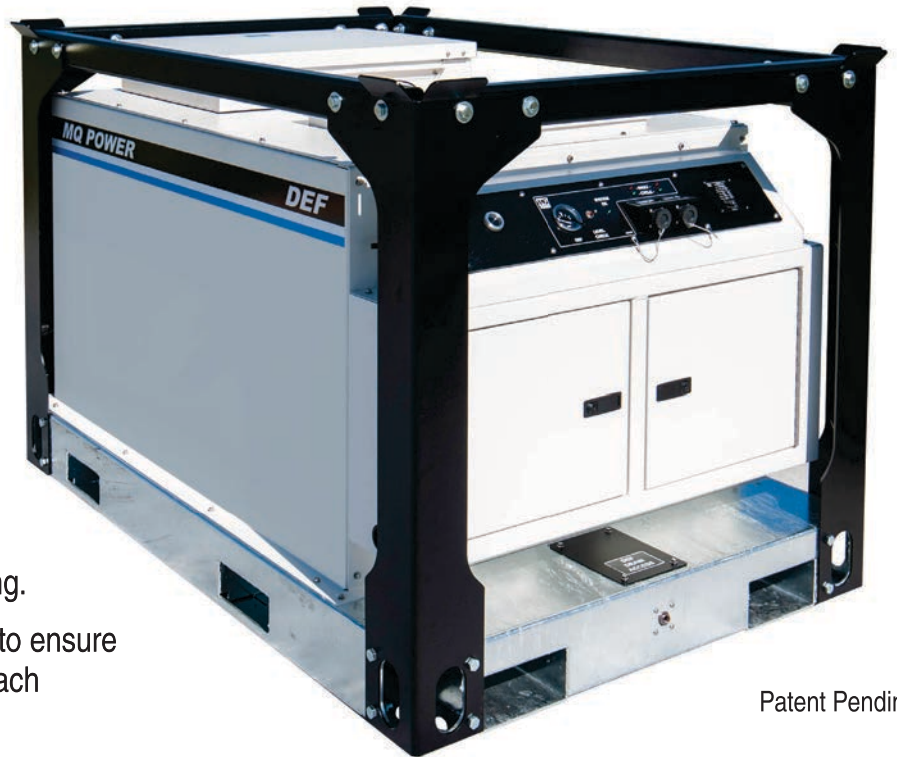

Patent Pending

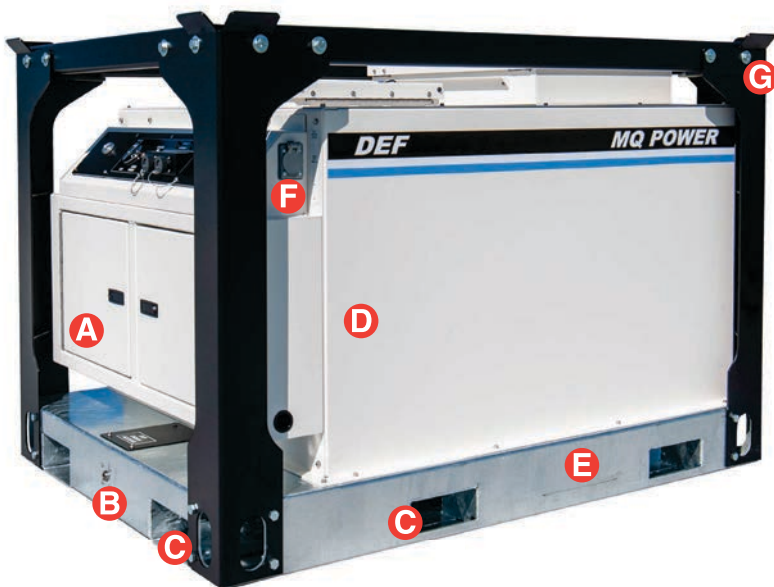

- A. **Lockable Storage Compartments** on top and front panels secure accessories
- B. **Quick Access Hatch** for drain valve
- C. **Front and Side Fork Pockets** for easy loading
- D. **Rugged textured** white powder-coated housing
- E. **Hot Dipped** corrosion-resistant galvanized base
- F. **120V Heat Pad** for cold weather operation (Optional)
- G. **Stacking Kit** for reduced foot print and lower transportation costs (Optional)

* Simultaneously supplying fluid for two generators requires Model DEFTANK2.

**QUICK DEPLOYMENT.
SIMPLE OPERATION.**

Sets up in minutes with an intuitive control panel that provides fluid level and critical operating information.

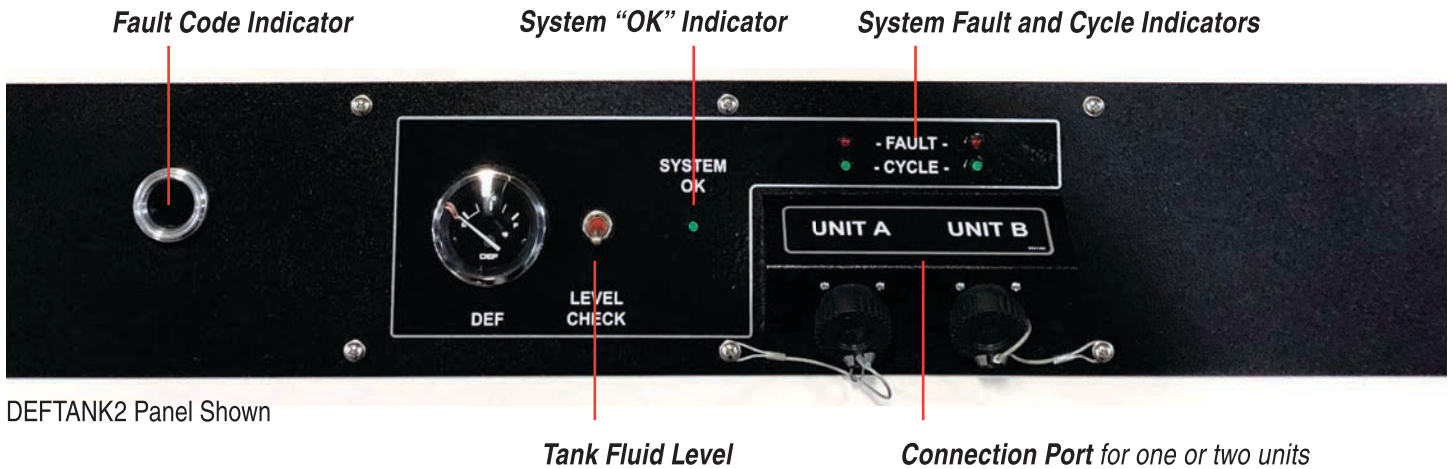

**REPLENISH ON THE GO WITH THE
MANUAL DISPENSING NOZZLE.**

The Manual Dispensing Option converts the DEFTANK into a portable, pumping station for remote refilling requirements.

Designed to fit within the bed of a standard pickup; an 8 GPM pump is included to eliminate costly refilling times and the expense associated with traditional methods.



**SECURELY STORE HOSE AND OTHER ACCESSORIES
INSIDE A LOCKABLE STEEL COMPARTMENT.**



DEFDISPENSERKIT includes:

20 ft. Dispensing Hose with Nozzle

20 ft. 12V DC Jumper Cables

DEFTANK Specifications

Model	DEFTANK1	DEFTANK2
Number of Generators	1	2
Unit Specifications		
System Voltage Requirements	12V DC Max.	
Amperage Requirements	5.0 Amps	5.0 Amps x 2
External Hose Length	25 ft.	25 ft. x 2
Communication Cable	25 ft.	25 ft. x 2
DEF Capacity		
Tank Capacity	100 gallons (379 liters)	
Fluid Type	Diesel exhaust fluid; complies with ISO-22241	
Weight		
Dry Weight	1,003 lb. (455 kg)	
Wet Weight	1,903 lb. (863 kg)	
Max. Lift Point Capacity	3,000 lb. (1360 kg)	

Optional Manual Dispensing Nozzle

DEFDISPENSERKIT KIT Specifications	
DEF Flow	8 gpm / 30.28 lpm
Nozzle Size	3/4"
Pressure	38 psi max
Motor Amps	22
Motor Voltage	12V DC
Pump Motor	1/4 HP
Duty Cycle	30 min.
Hose Length	20 ft.
Material	Poly laminated stainless steel
Weight	17 lb. / 7.71 kg

Warranty — 24 months from date of purchase. Refer to Multiquip Limited Warranty for complete terms and conditions.

Features and specifications are subject to change without notice.

This product is designed for use with diesel exhaust fluid only (DEF) and is not intended for storage or dispensing of fuels or chemicals.

Optional Equipment

Model	Description
DEFTANK2KIT	Kit converts DEFTANK1 to DEFTANK2
DEFADAPTERKITA*	DEF Unit Connection Kit DCA70/125I T4F
DEFADAPTERKITB*	DEF Unit Connection Kit DCA70JD T4F
DEFADAPTERKITC*	DEF Unit Connection Kit DCA150-300 T4F
DEFADAPTERKITD*	DEF Unit Connection Kit DCA400 T4F
DEFHOSEHEAT	Heated Hose DCA150-400 T4F 20 ft.
DEFTANKHEATPAD	Heat Blanket 1500W 120VAC
DEFTANKSTACKKITP	4-Point Lift and Stack Assy. (Black Paint)
DEFTANKSTACKKITG	4-Point Lift and Stack Assy. (Galvanized)
DEFDISPENSERKIT	Nozzle with 20 ft. Hose; 12 VDC Manual Pump

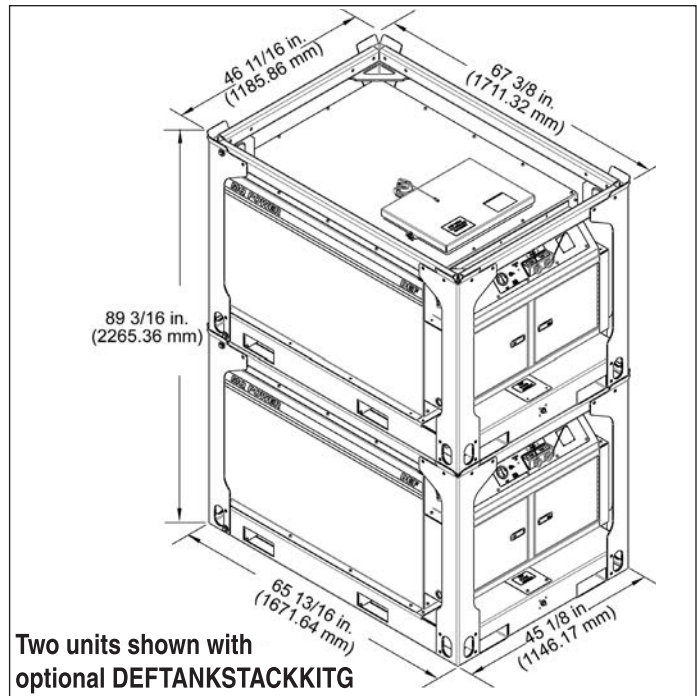

For additional dimensions, reference the DEFTANK data sheet.

* Required for use with specified DCA generators.